

Guided Microwave

VEGAFLEX 61
VEGAFLEX 62
VEGAFLEX 66



Product Information



VEGA

Content

1	Description of the measuring principle	3
2	Type overview	5
3	Mounting instructions.	8
4	Electrical connection	
4.1	General prerequisites	10
4.2	Voltage supply	10
4.3	Connection cable	10
4.4	Connection of the cable screen and grounding	10
4.5	Wiring plan	11
5	Operation	
5.1	Overview	12
5.2	Compatibility according to NAMUR NE 53	12
5.3	Adjustment with the indicating and adjustment module PLICSCOM	12
5.4	Adjustment with PACTware™	12
6	Technical data	14
7	Dimensions.	23
8	Product code	26

Take note of safety instructions for Ex applications



Please note the Ex specific safety information which you can find on our homepage www.vega.com/services/downloads and which comes with every instrument. In hazardous areas you should take note of the appropriate regulations, conformity and type approval certificates of the sensors and power supply units. The sensors must only be operated on intrinsically safe circuits. The permissible electrical values are stated in the certificate.

1 Description of the measuring principle

Measuring principle

High frequency microwave impulses are guided along a steel cable or rod. When they reach the product surface, the microwave pulses are reflected back and received by the processing electronics. The running time is processed by the instrument.

A microprocessor identifies these level echoes, which are subsequently measured by the ECHOFOX software, evaluated and converted into level information.

Time-consuming adjustment with medium is not necessary. The instruments are preset to the ordered probe length. The shortenable cable and rod versions can be adapted individually to the local requirements.

Insensitive to dust

Even process conditions such as intense dust generation do not influence the measurement function.

Unaffected by material fluctuations

Density fluctuations or changes of the dielectric constant do not influence the function.

Buildup: no problem

Buildup or condensation on the probe or vessel wall do not influence the measuring result.

Wide application range

With measuring ranges up to 60 m (197 ft), the sensors are well suited for tall vessels. Temperatures up to 150 °C (302 °F) and pressures from vacuum up to 40 bar (580 psig) ensure a wide application range.

VEGAFLEX 66 is particularly suitable for the measurement of solids with high process temperatures. Its mechanical configuration was specially optimised for such applications. With these high temperature versions, process temperatures from -200° to +400° C (-328 ... +752 °F) and pressures up to 400 bar (5800 psig) are possible.

Insensitive to noise

VEGAFLEX sensors are insensitive to filling noise.

1.1 Application examples

Foodstuffs and animal feed

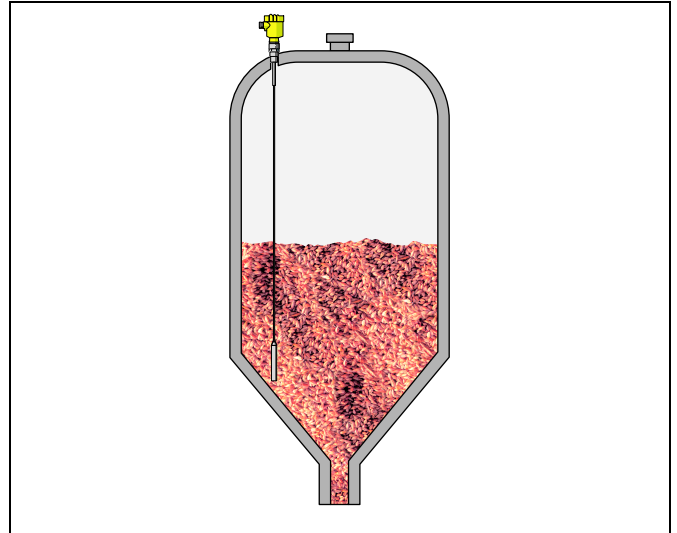

Fig. 1: Level measurement in a grain silo with VEGAFLEX 61

Cereals, sugar, flour, coffee, cornflakes, cacao, instant powder, animal feed - bulk solid levels must be measured everywhere in the food industry.

The guided microwave principle works independent of product characteristics such as moisture, intense dust or noise generation and the shape of the material cone.

Even very tall silos are no problem. Cable probes, also with PA coating, are available for different loads and in lengths up to 60 m (197 ft).

VEGAFLEX meets also the requirements of dust-Ex zone 20 (1/2 D).

Plastics

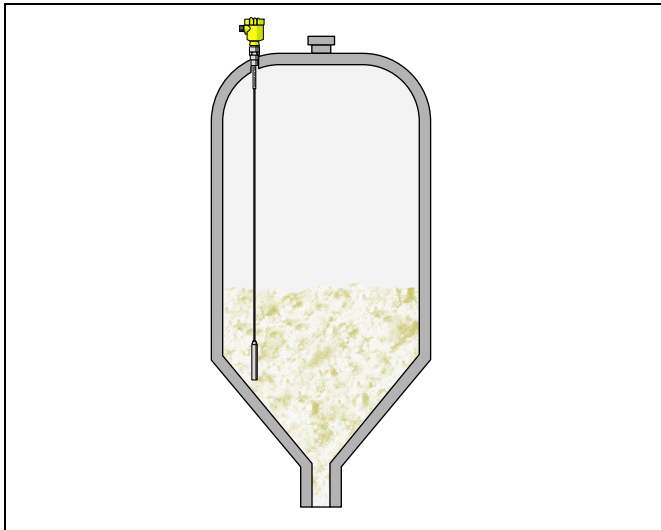

Fig. 2: Level measurement of plastic granules with VEGAFLEX 61

Many finished products in the chemical industry are produced as powder, granules or pellets. The different and sometimes fluctuating product characteristics place heavy demands on the level measurement.

The measuring result is influenced neither by fluctuating product quality nor by dust generation or the shape of the material cone.

Even strong electrostatic discharges cannot harm VEGAFLEX 61.

Unaffected by product properties, the sensor delivers accurate, reproducible level data.

Building materials

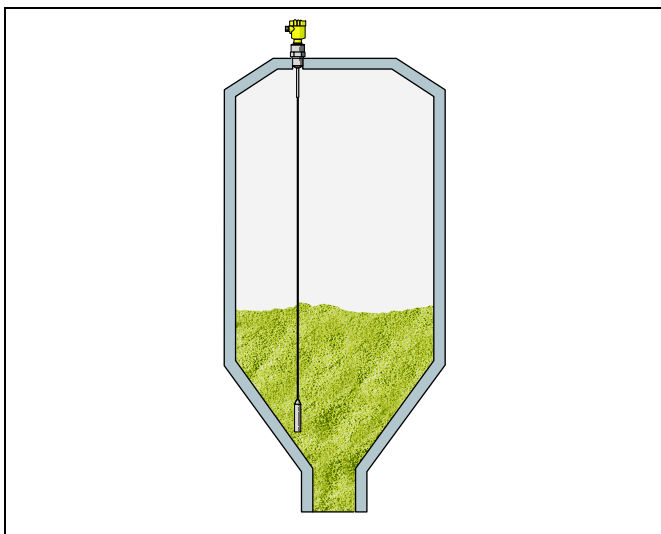

Fig. 3: Level measurement in a storage vessel with VEGAFLEX 62

In the building industry, different additives are stored in single or multiple chamber silos - e.g. cement, sand, filler with varying

properties such as moisture content, grain size, material cone shape and flow behavior.

The guided microwave is ideal for level measurement in vessels containing bulk solids. Due to the physical measuring principle, adjustment with medium is no longer necessary. The sensor only has to be electrically connected.

The measuring result is influenced neither by fluctuating product quality nor by dust generation, condensation or the shape of the material cone and therefore has a high reproducibility.

Cable probes are available for different lengths and loads. Tractive forces on the cable up to 3 tons (6000 lbs) are no problem for the stable VEGAFLEX 62.

The measurement is unaffected by product properties such as density, temperature, dielectric value and buildup. Because it is available in a wide range of versions, VEGAFLEX can also measure products such as e.g. light-weight fly ash or hot asphalt.

2 Type overview

VEGAFLEX 61 with cable measuring probe



Application:	Bulk solids
Measuring range:	0.15 ... 32 m (0.492 ... 104.99 ft)
Process fitting:	Thread, flange
Material:	316L and PCTFE, 316
Process temperature:	-40 ... +150 °C (-40 ... +302 °F)
Process pressure:	-1 ... 40 bar/-100 ... 4000 kPa (-14.5 ... 580 psig)
Signal output:	4 ... 20 mA/HART in two-wire, four-wire, Profibus PA, Foundation Fieldbus technology

VEGAFLEX 61 with rod measuring probe



Application:	Bulk solids
Measuring range:	0.15 ... 4 m (0.492 ... 13.12 ft)
Process fitting:	Thread, flange
Material:	316L and PCTFE, Hastelloy C22 (2.4602)
Process temperature:	-40 ... +150 °C (-40 ... +302 °F)
Process pressure:	-1 ... 40 bar/-100 ... 4000 kPa (-14.5 ... 580 psig)
Signal output:	4 ... 20 mA/HART in two-wire, four-wire, Profibus PA, Foundation Fieldbus technology

VEGAFLEX 62 with cable measuring probe



Application:	Bulk solids
Measuring range:	0.15 ... 60 m (0.492 ... 196.9 ft)
Process fitting:	Thread, flange
Material:	316L and PCTFE, 316
Process temperature:	-40 ... +150 °C (-40 ... +302 °F)
Process pressure:	-1 ... 40 bar/-100 ... 4000 kPa (-14.5 ... 580 psig)
Signal output:	4 ... 20 mA/HART in two-wire, four-wire, Profibus PA, Foundation Fieldbus technology

VEGAFLEX 62 with rod measuring probe



Application:	Bulk solids
Measuring range:	0.15 ... 4 m (0.492 ... 13.12 ft)
Process fitting:	Thread, flange
Material:	316L and PCTFE, Hastelloy C22 (2.4602)
Process temperature:	-40 ... +150 °C (-40 ... +302 °F)
Process pressure:	-1 ... 40 bar/-100 ... 4000 kPa (-14.5 ... 580 psig)
Signal output:	4 ... 20 mA/HART in two-wire, four-wire, Profibus PA, Foundation Fieldbus technology

VEGAFLEX 66 with cable measuring probe



VEGAFLEX 66 with rod measuring probe



Application: Bulk solids
 Measuring range: 1 ... 32 m (3.28 ... 104.99 ft)
 Process fitting: Thread, flange
 Material: 316L and Aluminium oxide-ceramic 99.7 % (Al₂O₃),
 Hastelloy C22 and Aluminium oxide-ceramic 99.7 % (Al₂O₃)
 Process temperature: -200 ... +400 °C (-328 ... +752 °F)
 Process pressure: -1 ... 400 bar/-100 ... 40000 kPa (-14.5 ... 5800 psig)
 Signal output: 4 ... 20 mA/HART in two-wire, four-wire, Profibus PA,
 Foundation Fieldbus technology

Application: Bulk solids
 Measuring range: 0.5 ... 6 m (1.64 ... 19.69 ft)
 Process fitting: Thread, flange
 Material: 316L and Aluminium oxide-ceramic 99.7 % (Al₂O₃)
 Process temperature: -200 ... +400 °C (-328 ... +752 °F)
 Process pressure: -1 ... 400 bar/-100 ... 40000 kPa (-14.5 ... 5800 psig)
 Signal output: 4 ... 20 mA/HART in two-wire, four-wire, Profibus PA,
 Foundation Fieldbus technology

Indicating and adjustment module



PLICSCOM

Housing



Plastic



Stainless steel



Aluminium



Aluminium (double chamber)

Electronics



4 ... 20 mA/HART
two-wire



4 ... 20 mA/HART
four-wire



Profibus PA



Foundation Field-
bus

Process fitting



Thread



Flange

Sensors



Cable probe



Rod probe

Approvals



Dust-explosion pro-
tection



SIL

3 Mounting instructions

Measuring range

The reference plane for the measuring range of the sensors is the sealing surface of the thread or flange.

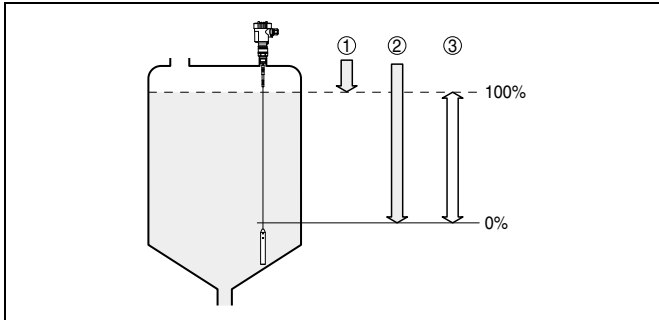

Fig. 4: Measuring range (operating range) and max. measuring distance

- 1 full
- 2 empty (max. measuring distance)
- 3 Measuring range

Keep in mind that a min. distance must be maintained below the reference plane and possibly also at the end of the probe - measurement in these areas is not possible (dead band). Keep in mind that the cable length cannot be used all the way to the end because measurement in the area of the gravity weight is not possible. A possible overfilling however, is also detected reliably within the dead band.

These min. distances (dead zones) are specified in chapter "Technical data".

Installation position

Mount VEGAFLEX so that the probe does not touch any installations or the vessel wall during operation. If necessary, fasten the probe end.

When mounting the cable and rod versions of VEGAFLEX keep at least a distance of 300 mm (11.81 in) to vessel installations or the vessel wall.

If possible, mount the sensor flush with the vessel top. If this is not possible, use short sockets with small diameter.

In case of unfavourable mounting conditions such as e.g. very high ($h > 200 \text{ mm}/7.9 \text{ in}$) or very wide ($\varnothing > 200 \text{ mm}/7.9 \text{ in}$) sockets or a too small distance to the vessel wall or vessel installations ($< 300 \text{ mm}/11.81 \text{ in}$), we recommend carrying out a false echo suppression for the area in question. Use the adjustment software PACTware™ with DTM.

Inflowing medium

Make sure that the probe is not subjected to strong lateral forces. Mount VEGAFLEX at a position in the vessel where no mechanical disturbances, e.g. from filling openings, agitators, etc., can occur.

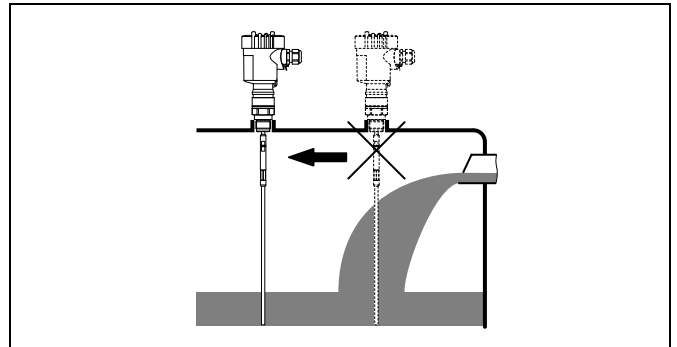

Fig. 5: Lateral load

Type of vessel

Plastic vessel

The guided microwave principle requires a metal surface on the process fitting. Therefore use in plastic vessels etc. an instrument version with flange (from DN 50) or place a metal sheet ($\varnothing > 200 \text{ mm}/8 \text{ in}$) beneath the process fitting when screwing it in.

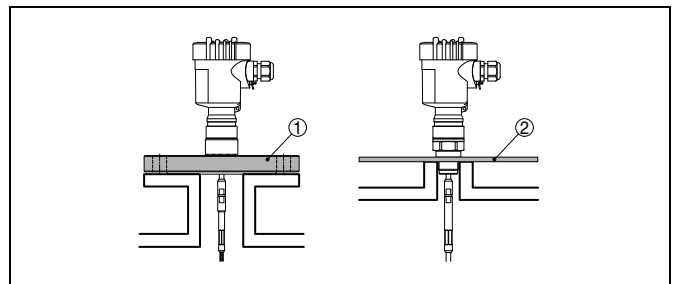

Fig. 6: Installation in plastic silo

- 1 Flange
- 2 Metal plate

Concrete vessel

When installed in thick concrete ceilings, VEGAFLEX should be mounted front flush to the lower edge. In concrete silos, the distance to the wall should be at least 500 mm (20 in).

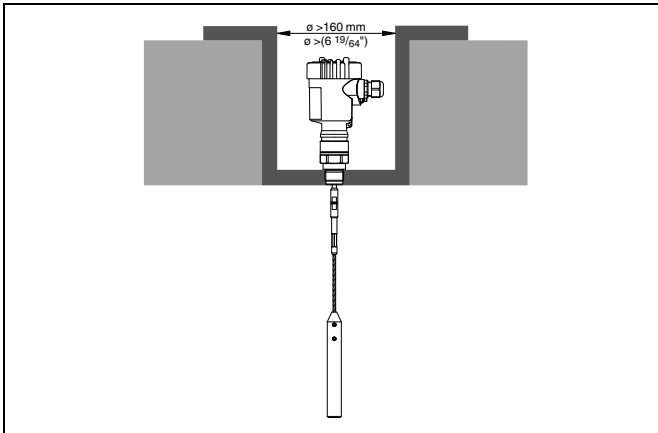

Fig. 7: Installation in concrete silo

Fixing

If there is a danger of the probe touching the vessel wall during operation due to product movements or agitators etc., the measuring probe should be securely fixed.

In the gravity weight there is a thread (M12), e.g. for a ring bolt (article no. 2.27424).

Make sure that the probe cable is not extremely taut. Avoid tensile loads on the cable. Use a slightly pre-stressed tension spring to fasten the cable. Also take note of the max. tensile load. The tensile load is specified in chapter "Technical data".

Avoid undefined cable-vessel connections, i.e. the connection must be either grounded reliably or isolated reliably. Any uncontrolled deviation from this requirement can lead to measurement errors.

4 Electrical connection

4.1 General prerequisites

The supply voltage range can differ depending on the instrument version. You can find exact specifications in chapter "Technical data".

The national installation standards as well as the valid safety regulations and accident prevention rules must be observed.



In hazardous areas you should take note of the appropriate regulations, conformity and type approval certificates of the sensors and power supply units.

4.2 Voltage supply

4 ... 20 mA/HART two-wire

Supply voltage and current signal are carried on the same two-wire cable. The requirements on the power supply are specified in chapter "Technical data".

The VEGA power supply units VEGATRENN 149AEx, VEGAS-TAB 690, VEGADIS 371 as well as the VEGAMET signal conditioning instruments are suitable for power supply. When one of these instruments is used, a reliable separation of the supply circuit from the mains circuits according to DIN VDE 0106 part 101 and protection class II is ensured.

4 ... 20 mA/HART four-wire

Power supply and current output are carried on two separate connection cables.

The standard version can be operated with an earth-connected current output, the Exd version must be operated with a floating output.

The instrument is designed in protection class I. To maintain this protection class, it is absolutely necessary that the ground conductor be connected to the internal ground conductor terminal.

Profibus PA

Power is supplied by a Profibus DP/PA segment coupler or a VEGALOG 571 EP input card.

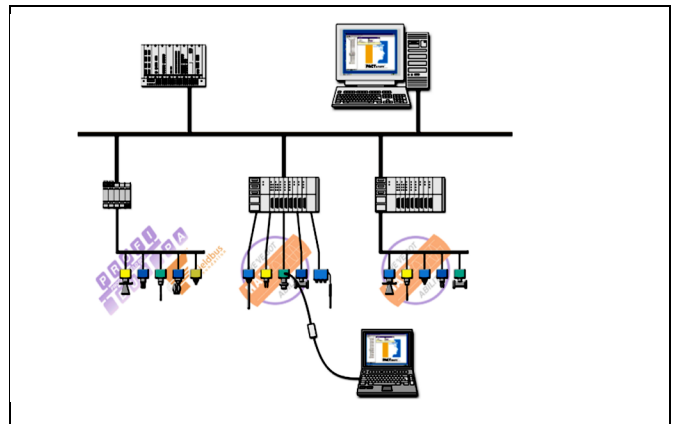

Fig. 8: Integration of instruments in a Profibus PA system via segment coupler DP/PA or data recording systems with Profibus PA input card

Foundation Fieldbus

Power supply via the H1 Fieldbus cable.

4.3 Connection cable

Generally

The sensors are connected with standard cable without screen. An outer cable diameter of 5 ... 9 mm ensures the seal effect of the cable entry.

4 ... 20 mA/HART two-wire and four-wire

If electromagnetic interference is expected which is above the test values of EN 61326 for industrial areas, screened cable should be used. In HART multidrop mode the use of screened cable is generally recommended.

Profibus PA, Foundation Fieldbus

The installation must be carried out according to the appropriate bus specification. The sensor is connected respectively with screened cable according to the bus specification. Make sure that the bus is terminated via appropriate terminating resistors.

For power supply, an approved installation cable with PE conductor is also required.



In Ex applications, the corresponding installation regulations must be noted for the connection cable.

4.4 Connection of the cable screen and grounding

If screened cable is necessary, the cable screen must be connected on both ends to ground potential. If potential equalisation currents are expected, the connection on the evaluation side must be made via a ceramic capacitor (e.g. 1 nF, 1500 V).

Profibus PA, Foundation Fieldbus

In systems with potential separation, the cable screen is connected directly to ground potential on the power supply unit, in the connection box and directly on the sensor.

In systems without potential equalisation, connect the cable screen directly to ground potential only at the power supply unit and at the sensor - do not connect to ground potential in the connection box or T-distributor.

4.5 Wiring plan

Single chamber housing

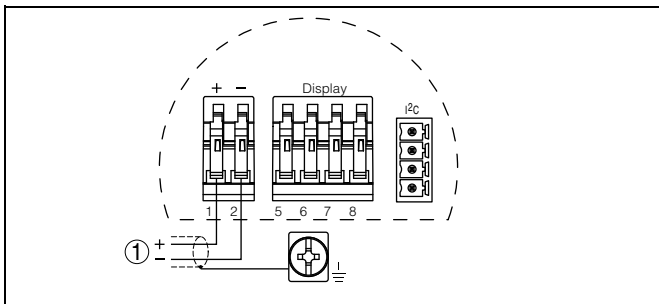

Fig. 9: Connection HART two-wire, Profibus PA, Foundation Fieldbus

1 Voltage supply and signal output

Double chamber housing - two-wire

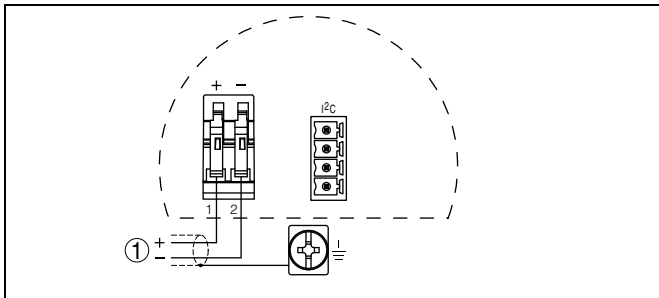

Fig. 10: Connection HART two-wire, Profibus PA, Foundation Fieldbus

1 Voltage supply and signal output

Double chamber housing - 4 ... 20 mA/HART four-wire

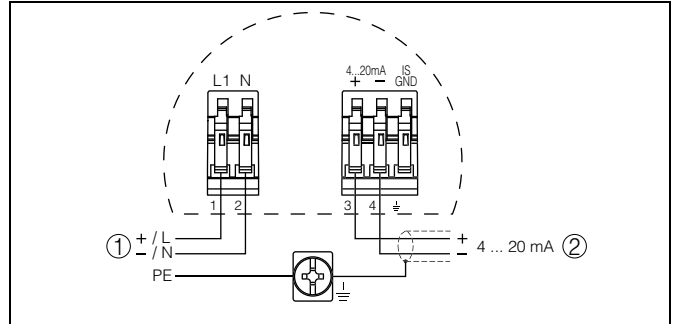

Fig. 11: Connection 4 ... 20 mA/HART four-wire

- 1 Voltage supply
- 2 Signal output

5 Operation

5.1 Overview

The sensors can be adjusted with the following adjustment media:

- with indicating and adjustment module
- an adjustment software according to FDT/DTM standard, e.g. PACTware™ and PC

and, depending on the signal output, also with:

- a HART handheld (4 ... 20 mA/HART)
- The adjustment program AMS (4 ... 20 mA/HART and Foundation Fieldbus)
- The adjustment program PDM (Profibus PA)
- a configuration tool (Foundation Fieldbus)

The entered parameters are generally saved in the sensor, optionally also in the indicating and adjustment module or in the adjustment program.

5.2 Compatibility according to NAMUR NE 53

VEGAFLEX meet NAMUR recommendation NE 53. VEGA instruments are generally upward and downward compatible:

- Sensor software to DTM VEGAFLEX HART, PA or FF
- DTM VEGAFLEX for adjustment software PACTware™
- Indicating and adjustment module PLICSCOM for sensor software

The parameter adjustment of the basic sensor functions is independent of the software version. The range of available functions depends on the respective software version of the individual components.

5.3 Adjustment with the indicating and adjustment module PLICSCOM

Setup and indication

PLICSCOM is a pluggable indication and adjustment module for plics® sensors. It can be placed in four different positions on the instrument (each displaced by 90°). Indication and adjustment are carried out via four keys and a clear, graphic-capable dot matrix display. The adjustment menu with language selection is clearly structured and enables easy setup. After setup, PLICSCOM serves as indicating instrument: through the screwed cover with glass insert, measured values can be read directly in the requested unit and presentation style.

The integrated background lighting of the display can be switched on via the adjustment menu.¹⁾

¹⁾ For instruments with national approvals such as e.g. according to FM or CSA only available at a later date.

PLICSCOM adjustment

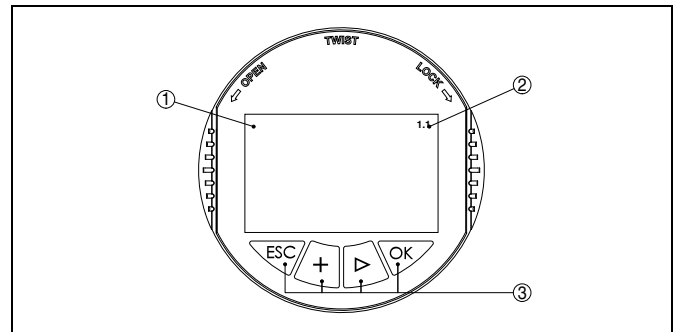

Fig. 12: Indicating and adjustment elements

- 1 LC display
- 2 Indication of the menu item number
- 3 Adjustment keys

Key functions

- **[OK]** key:
 - Move to the menu overview
 - Confirm selected menu
 - Edit parameter
 - Save value
- **[->]** key to select:
 - menu change
 - list entry
 - Select editing position
- **[+]** key:
 - Change value of the parameter
- **[ESC]** key:
 - interrupt input
 - jump to the next higher menu

5.4 Adjustment with PACTware™

PACTware™/DTM

Independent of the respective signal output 4 ... 20 mA/HART, Profibus PA or Foundation Fieldbus, the sensors can be operated directly on the instrument via PACTware™. The sensors with signal output 4 ... 20 mA/HART can be also operated via the HART signal on the signal cable.

An VEGACONNECT interface adapter as well as an instrument driver for the respective sensor is necessary for the adjustment with PACTware™. All currently available VEGA DTMs are included as DTM Collection with the current PACTware™ version on a CD. They are available for a protective fee from our respective VEGA agency. In addition, this DTM Collection incl. the basic

version of PACTware™ can be downloaded free-of-charge from the Internet.

To use the entire range of functions of a DTM, incl. project documentation, a DTM licence is required for that particular instrument family. This licence can be bought from the VEGA agency serving you.

Connect the PC via VEGACONNECT 3

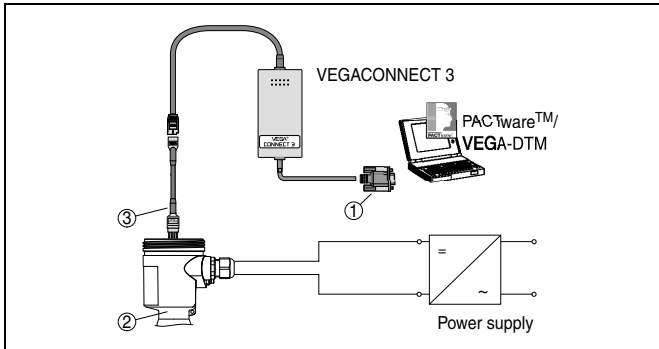

Fig. 13: Connection of the PC directly to the sensor via I²C interface

- 1 RS232 connection
- 2 VEGAFLEX
- 3 I²C adapter cable for VEGACONNECT 3

To adjust with PACTware™, a VEGACONNECT 3 with I²C adapter cable (art. no. 2.27323) as well as a power supply unit is necessary in addition to the PC and the suitable VEGA-DTM.

Connect the PC via VEGACONNECT 4

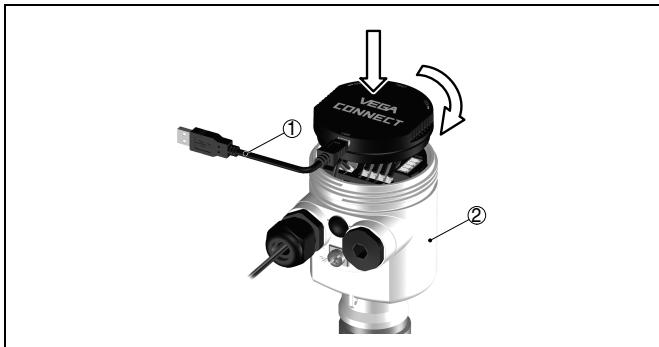

Fig. 14: Internal connection of the PC directly to the sensor via I²C interface

- 1 USB cable
- 2 Sensor

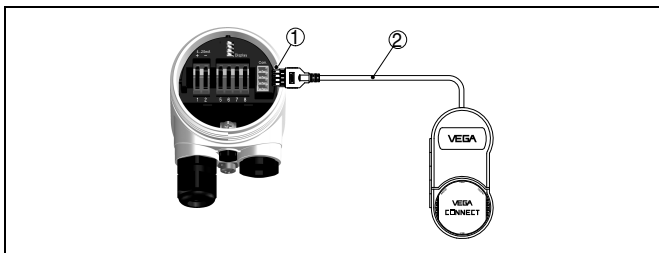

Fig. 15: External connection of the PC directly to the sensor via I²C interface

- 1 I²C bus (Com.) interface
- 2 I²C connection cable of VEGACONNECT 4

29658-EN-071204

6 Technical data

General data

Material 316L corresponds to 1.4404 or 1.4435; 316 corresponds to 1.4401

VEGAFLEX 61

Materials, wetted parts

- | | |
|---|--|
| <ul style="list-style-type: none"> – Process fitting – Process seal on the instrument side (cable/rod leadthrough) – Process seal – inner conductor (up to the separation cable/rod) – Rod: \varnothing 6 mm (0.236 in) – Cable: \varnothing 4 mm (0.157 in) with gravity weight (optional) | 316L and PCTFE, Hastelloy C22 (2.4602) and PCTFE
FKM (e.g. Viton), Kalrez 6375, EPDM, FKM (e.g. Viton) FEP-coated
On site (instruments with thread: Klingersil C-4400 is attached)
1.4462
316L/Hastelloy C22 (2.4602)
316 |
|---|--|

VEGAFLEX 62

Process fitting - cable version

316L and PTFE

Process fitting - rod version

316L and PTFE, Hastelloy C22 (2.4602) and PTFE

Process seal on the instrument side (cable/rod leadthrough)

FKM (e.g. Viton), Kalrez 6375, EPDM, FKM (e.g. Viton) FEP-coated

Process seal

On site (instruments with thread: Klingersil C-4400 is attached)

Cable: \varnothing 6 mm (0.236 in)

316

Rod: \varnothing 16 mm (0.63 in)

316L, Hastelloy C22 (2.4602)

VEGAFLEX 66

Materials, wetted parts - version -200 ... +400 °C (-328 ... +752 °F)

- | | |
|---|---|
| <ul style="list-style-type: none"> – Process fitting with rod version – Process fitting with cable version – Rod: \varnothing 16 mm (0.63 in) – Cable: \varnothing 6 mm (0.236 in) – Process seal on the instrument side (cable/rod leadthrough) – Process seal | 316L, Hastelloy C22 (2.4602) and Aluminium oxide ceramic 99.7 % (Al ₂ O ₃)
316L, Hastelloy C22 (2.4602) and Aluminium oxide ceramic 99.7 % (Al ₂ O ₃)
316L
316
graphite
On site (instruments with thread: Klingersil C-4400 is attached) |
|---|---|

Materials, non-wetted parts

Materials, non-wetted parts

- | | |
|--|--|
| <ul style="list-style-type: none"> – Housing – Seal between housing and housing cover – Inspection window in housing cover for PLICSCOM (optional) – Ground terminal | Plastic PBT (polyester), Alu die-casting powder-coated, 316L
NBR (stainless steel housing), silicone (Alu/plastic housing)
Polycarbonate
316L |
|--|--|

Weights approx.

Weights

- | | |
|--|---|
| <ul style="list-style-type: none"> – Depending on process fitting – Instrument weight VEGAFLEX 61, 62 – Instrument weight VEGAFLEX 66 (-200 ... +400 °C/-328 ... +752 °F) – Cable: \varnothing 4 mm (0.157 in) – Cable: \varnothing 6 mm (0.236 in) – Rod: \varnothing 6 mm (0.236 in) – Rod: \varnothing 16 mm (0.63 in) – Gravity weight (optional: \varnothing 4 mm (0.157 in)) – Gravity weight (optional: \varnothing 6 mm (0.236 in)) | approx. 0.8 ... 8 kg (0.176 ... 17.64 lbs)
approx. 6 ... 12 kg (13.23 ... 26.46 lbs)
80 g/m (0.86 oz/ft)
170 g/m (1.8 oz/ft)
220 g/m (2.365 oz/ft)
1600 g/m (17.2 oz/ft)
325 g (11.5 oz)
730 g (25.8 oz) |
|--|---|

Lengths

Lengths (L)

- | | |
|--|--|
| <ul style="list-style-type: none"> – Cable: \varnothing 4 mm (0.157 in) – Cable: \varnothing 6 mm (0.236 in) – Trimming accuracy - cable – Rod: \varnothing 6 mm (0.236 in) – Rod: \varnothing 16 mm (0.63 in) – Trimming accuracy - rod | 1 ... 32 m (3.28 ... 104.99 ft)
1 ... 60 m (3.28 ... 196.9 ft)
\pm 0.05 %
0.3 ... 4 m (0.984 ... 13.12 ft)
0.3 ... 4 m (0.984 ... 13.12 ft)
< 1 mm (0.039 in) |
|--|--|

Lateral load

Lateral load

- Rod: \varnothing 6 mm (0.236 in)
- Rod: \varnothing 16 mm (0.63 in)

- 4 Nm (3 lbf ft)
- 30 Nm (22 lbf ft)

Max. tensile load

Max. tensile load

- VEGAFLEX 61 - cable: \varnothing 4 mm (0.157 in)
- VEGAFLEX 62 - cable: \varnothing 6 mm (0.236 in)
- VEGAFLEX 66 - cable: \varnothing 4 mm (0.157 in)

- 5 KN (1124 lbf)
- 30 KN (6745 lbf)
- 2.5 KN (562 lbf)

The tensile force of solids are subject of a normal fluctuation range. For this reason, the determined diagram value of the following diagrams must be multiplied with safety factor 2.

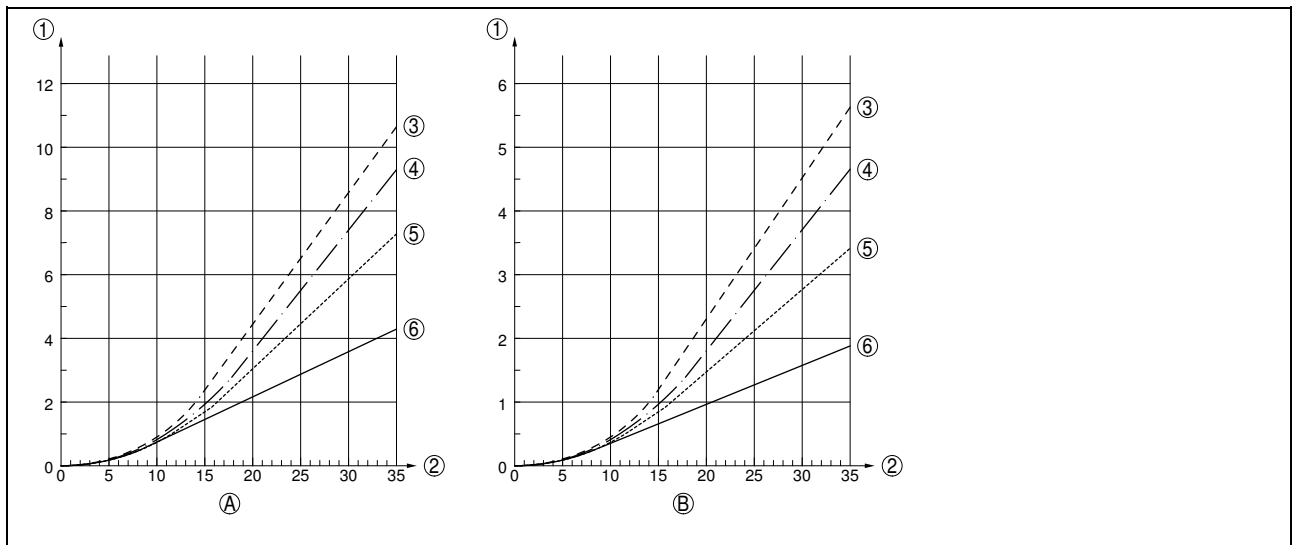

Fig. 16: Max. tensile load for VEGAFLEX 61 with cable: \varnothing 4 mm (0.157 in)

- A Cereals
- B Plastic granules
- 1 Tensile force in kN (the determined value must be multiplied with safety factor 2)
- 2 Cable length in m
- 3 Vessel diameter 12 m (39.37 ft)
- 4 Vessel diameter 9 m (29.53 ft)
- 5 Vessel diameter 6 m (19.69 ft)
- 6 Vessel diameter 3 m (9.843 ft)

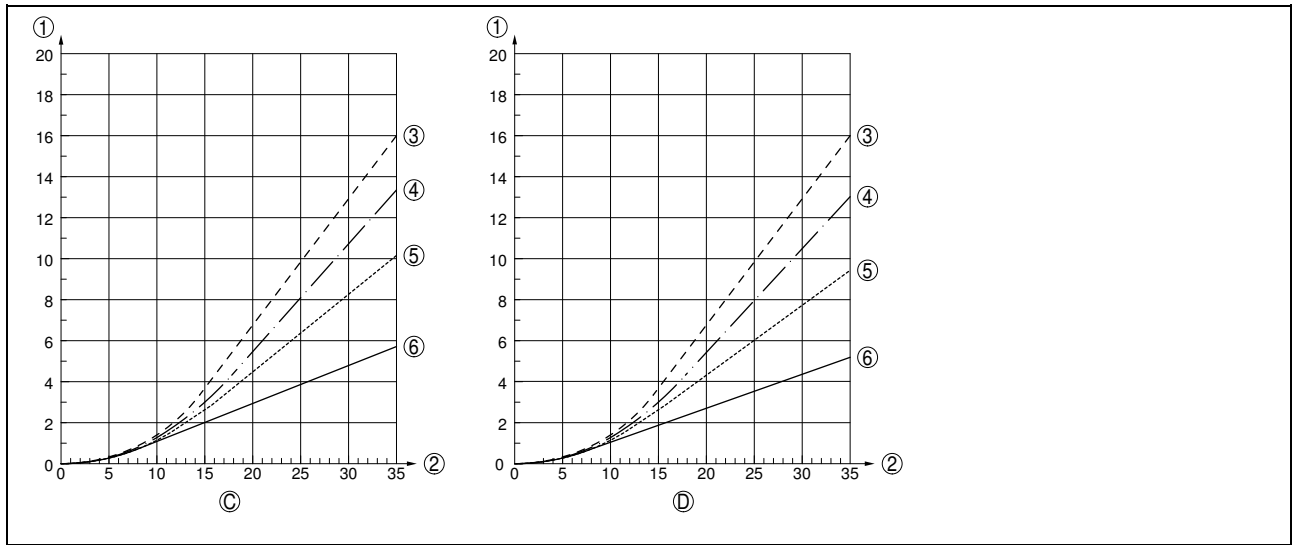

Fig. 17: Max. tensile load for VEGAFLEX 61 with cable: ø 4 mm (0.157 in)

- C Sand
- D Cement
- 1 Tensile force in kN (the determined value must be multiplied with safety factor 2)
- 2 Cable length in m
- 3 Vessel diameter 12 m (39.37 ft)
- 4 Vessel diameter 9 m (29.53 ft)
- 5 Vessel diameter 6 m (19.69 ft)
- 6 Vessel diameter 3 m (9.843 ft)

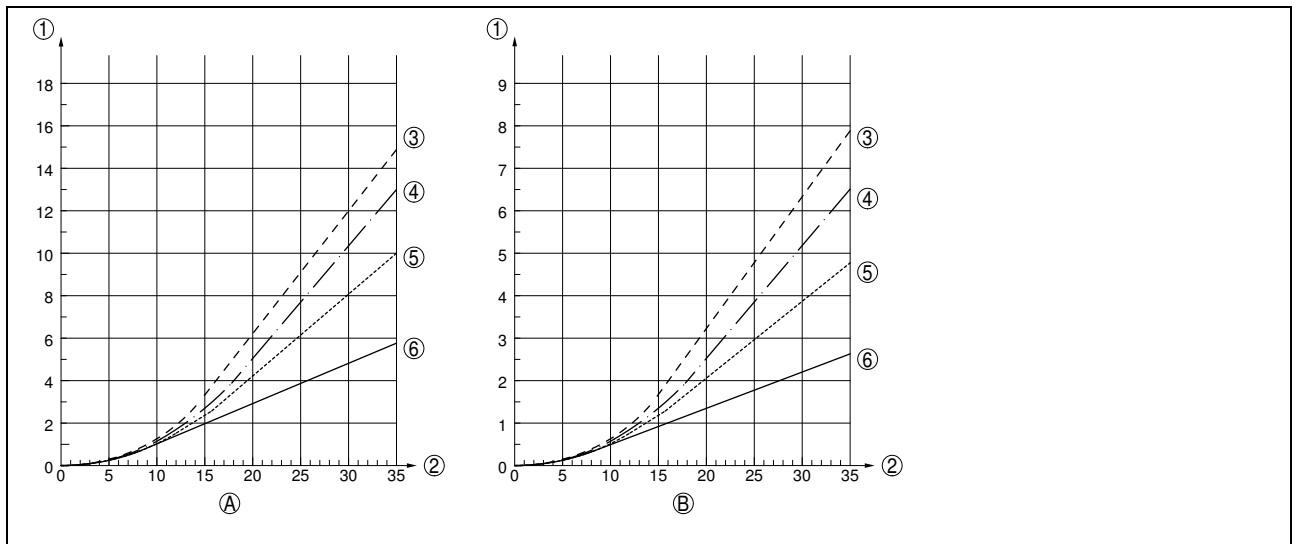

Fig. 18: Max. tensile load for VEGAFLEX 62 with cable: ø 6 mm (0.236 in)

- A Cereals
- B Plastic granules
- 1 Tensile force in kN (the determined value must be multiplied with safety factor 2)
- 2 Cable length in m
- 3 Vessel diameter 12 m (39.37 ft)
- 4 Vessel diameter 9 m (29.53 ft)
- 5 Vessel diameter 6 m (19.69 ft)
- 6 Vessel diameter 3 m (9.843 ft)

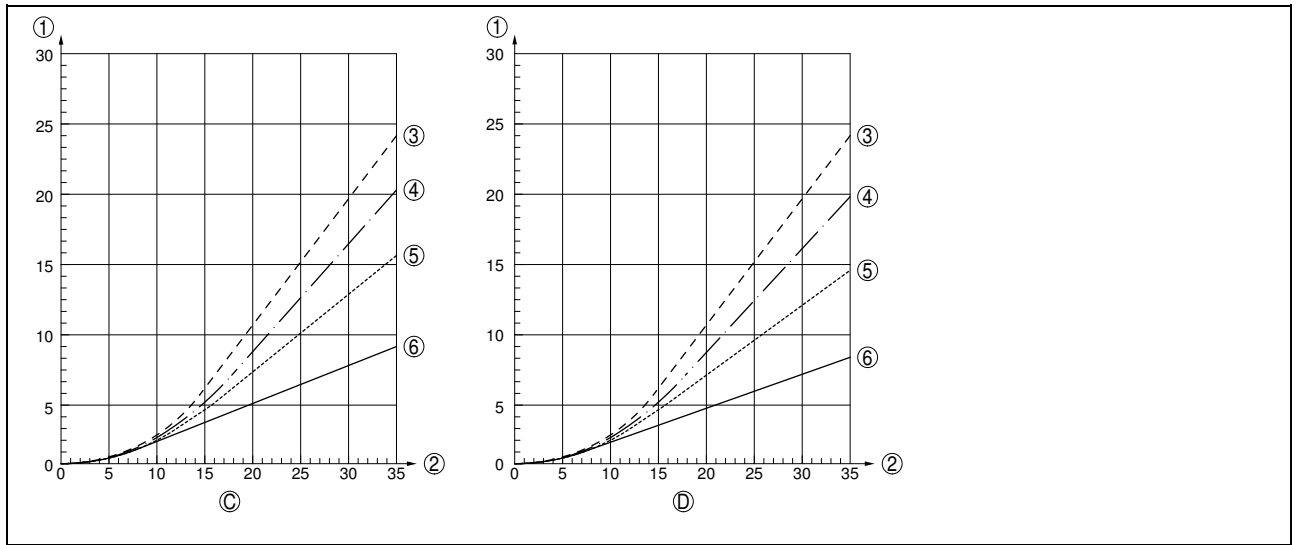

Fig. 19: Max. tensile load for VEGAFLEX 62 with cable: ø 6 mm (0.236 in)

- C Sand
- D Cement
- 1 Tensile force in kN (the determined value must be multiplied with safety factor 2)
- 2 Cable length in m
- 3 Vessel diameter 12 m (39.37 ft)
- 4 Vessel diameter 9 m (29.53 ft)
- 5 Vessel diameter 6 m (19.69 ft)
- 6 Vessel diameter 3 m (9.843 ft)

Output variable

4 ... 20 mA/HART

Output signal	4 ... 20 mA/HART
Signal resolution	1.6 µA
Fault message	Current output unchanged 20.5 mA, 22 mA, < 3.6 mA (adjustable)
Max. output current	22 mA
Load	see load diagram under Power supply
– 4 ... 20 mA/HART two-wire instrument	max. 500 Ohm ²⁾
– 4 ... 20 mA/HART four-wire instrument	
Damping (63 % of the input variable)	0 ... 999 s, adjustable
Fulfilled NAMUR recommendations	NE 43

Profibus PA

Output signal	digital output signal, format according to IEEE-754
Sensor address	126 (default setting)
Current value	10 mA, ±0.5 mA
Integration time (63 % of the input variable)	0 ... 999 s, adjustable

Foundation Fieldbus

Output	
– Signal	digital output signal, Foundation Fieldbus protocol
– Physical layer	according to IEC 61158-2
Channel Numbers	
– Channel 1	Primary Value
– Channel 2	Secondary Value 1
– Channel 3	Secondary Value 2
Transmission rate	31.25 Kbit/s
Current value	10 mA, ±0.5 mA
Integration time (63 % of the input variable)	0 ... 999 s, adjustable

29658-EN-071204

²⁾ With inductive load ohmic share min. 25 Ω/mH.

Input variable

Parameter	Level of solids
Cable and rod version	
Min. dielectric value with rod, cable version	$\epsilon_r > 1.6$
Dead zone with rod version (\varnothing 6 mm/0.236 in, \varnothing 16 mm/0.63 in)	
– top	80 mm (3.15 in)
– bottom	-
Dead band with cable version (\varnothing 4 mm/0.157 in, \varnothing 6 mm/0.236 in)	
– top	150 mm (5.91 in)
– bottom	250 mm (9.843 in), gravity weight + 100 mm (3.937 in)

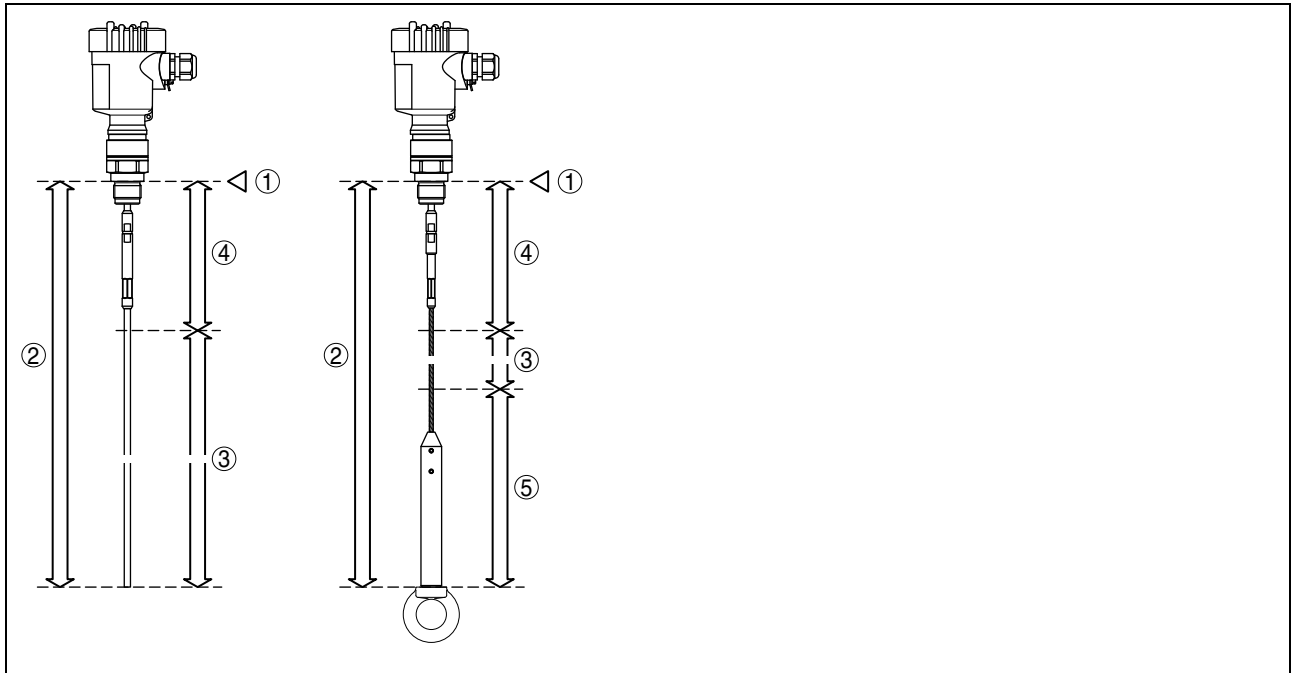

Fig. 20: Measuring ranges of VEGAFLEX with cable and rod version e.g. VEGAFLEX 61

- 1 Reference plane
- 2 Probe length
- 3 Measuring range
- 4 Upper dead band
- 5 Lower dead band (only with cable version)

Accuracy (similar to DIN EN 60770-1)

Reference conditions according to DIN EN 61298-1	
– Temperature	+18 ... +30 °C (+64 ... +86 °F)
– Relative humidity	45 ... 75 %
– Air pressure	860 ... 1060 mbar/86 ... 106 kPa (12.5 ... 15.4 psig)

Deviation in characteristics and characteristics

Reference installation conditions	
– Flange	DN 100
– min. distance to installations	1 m (3.28 ft)
– Min. distance to metal vessel bottom	20 mm (0.787 in)
Reference reflector	Metal plate: \varnothing 500 mm (19.69 in)
Temperature drift (current output)	0.06 %/10 K relating to the max. measuring range
Accuracy	
– Cable version	± 3 mm (0.118 in)
– Rod version	± 3 mm (0.118 in)

Ambient conditions

Ambient, storage and transport temperature -40 ... +80 °C (-40 ... +176 °F)

Process conditions

Process pressure

- Standard version -1 ... 40 bar/-100 ... 4000 kPa (-14.5 ... 580 psig), depending on the process fitting
- High temperature version -1 ... 400 bar/-100 ... 40000 kPa (-14.5 ... 5800 psig), depending on the process fitting

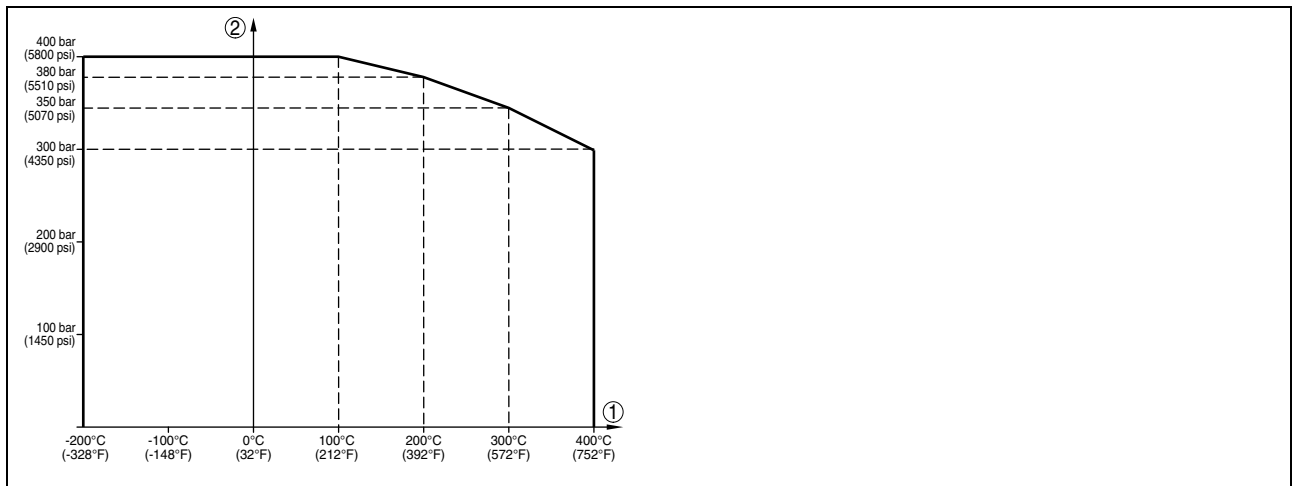

Fig. 21: Version -200 ... +400 °C (-328 ... +752 °F): dependency process pressure to product temperature

- 1 Product temperature
- 2 Process pressure

Process temperature (thread or flange temperature) - dependency from seal material

- FKM (e.g. Viton) -40 ... +150 °C (-40 ... +302 °F)
- FKM (e.g. Viton), FEP-coated -40 ... +150 °C (-40 ... +302 °F)
- EPDM -40 ... +150 °C (-40 ... +302 °F)
- Kalrez 6375 -20 ... +150 °C (-4 ... +302 °F)
- High temperature version (seal graphite) -200 ... +400 °C (-328 ... +752 °F)

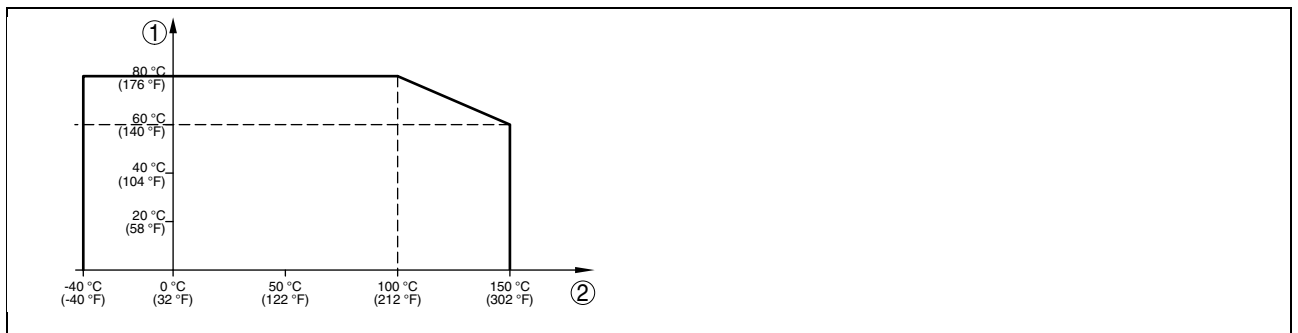

Fig. 22: Dependency ambient temperature to product temperature

- 1 Ambient temperature
- 2 Product temperature (depending on the seal material)

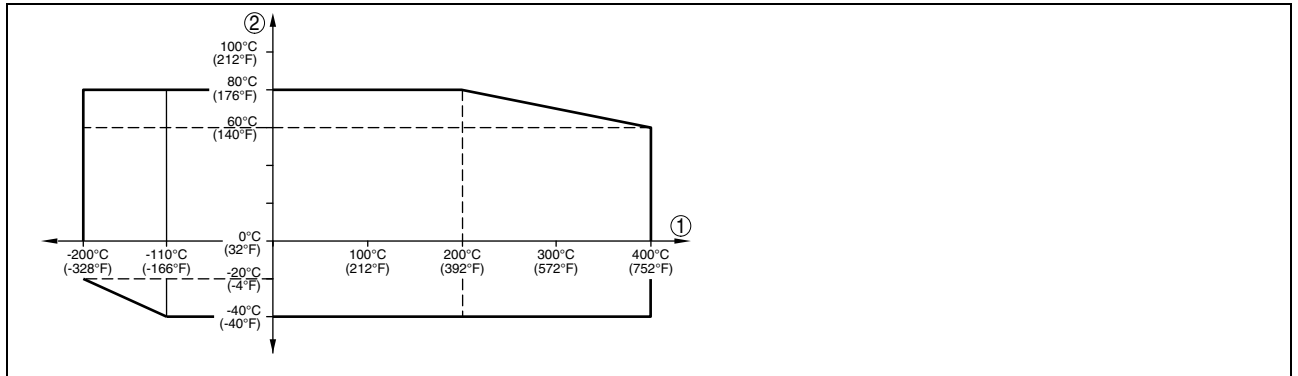

Fig. 23: Version -200 ... +400 °C (-328 ... +752 °F): in dependence on ambient temperature to product temperature

- 1 Ambient temperature
- 2 Product temperature (depending on the seal material)

Electromechanical data - version IP 66/IP 67 and IP 66/IP 68; 0.2 bar

Cable entry/plug³⁾

– Single chamber housing

- 1 x cable entry M20 x 1.5 (cable: ø 5 ... 9 mm), 1 x blind stopper M20 x 1.5

or:

- 1 x closing cap M20 x 1.5; 1 x blind stopper M20 x 1.5

or:

- 1 x closing cap ½ NPT, 1 x blind plug ½ NPT

or:

- 1 x plug (depending on the version), 1 x blind stopper M20 x 1.5

– Double chamber housing

- 1 x cable entry M20 x 1.5 (cable: ø 5 ... 9 mm), 1 x blind stopper M20 x 1.5; 1 x blind stopper M16 x 1.5 or optionally available with 1 x plug M12 x 1 for VEGADIS 61

or:

- 1 x closing cap ½ NPT, 1 x blind stopper ½ NPT, 1 x blind stopper M16 x 1.5 or optionally available with 1 x plug M12 x 1 for VEGADIS 61

or:

- 1 x plug (depending on the version), 1 x blind stopper M20 x 1.5; 1 x blind stopper M16 x 1.5 or optionally available with 1 x plug M12 x 1 for VEGADIS 61

Connection terminals

Spring-loaded terminals for wire cross-section up to 2.5 mm² (AWG 14)

Indicating and adjustment module

Power supply and data transmission

through the sensor

Indication

LC display in Dot matrix

Adjustment elements

4 keys

Protection

– unassembled

IP 20

– mounted into the sensor without cover

IP 40

Materials

– Housing

ABS

– Inspection window

Polyester foil

³⁾ Depending on the version M12x1, according to DIN 43650, Harting, Amphenol-Tuchel, 7/8" FF.

Power supply VEGAFLEX - two-wire instrument

4 ... 20 mA/HART

Supply voltage

- Non-Ex instrument 14 ... 36 V DC
- EEx-ia instrument 14 ... 30 V DC
- EEx-d-ia instrument 20 ... 36 V DC

Permissible residual ripple

- < 100 Hz $U_{ss} < 1 V$
- 100 Hz ... 10 kHz $U_{ss} < 10 mV$

Load see diagram

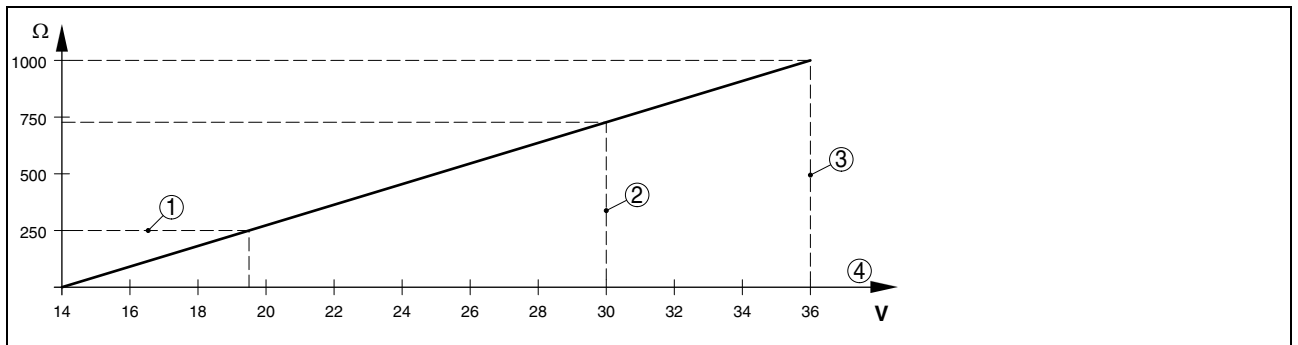

Fig. 24: Voltage diagram

- 1 HART load
- 2 Voltage limit EEx-ia instrument
- 3 Voltage limit non-Ex/Exd instrument
- 4 Supply voltage

Profibus PA

Supply voltage

- Non-Ex instrument 9 ... 32 V DC
- EEx-ia instrument 9 ... 24 V DC

Power supply by/max. number of sensors

- DP/PA segment coupler max. 32 (max. 10 with Ex)
- VEGALOG 571 EP card max. 15 (max. 10 with Ex)

Foundation Fieldbus

Supply voltage

- Non-Ex instrument 9 ... 32 V DC
- EEx-ia instrument 9 ... 24 V DC

Power supply by/max. number of sensors

- H1 Fieldbus cable/Voltage supply max. 32 (max. 10 with Ex)

Power supply VEGAFLEX - four-wire instrument

4 ... 20 mA

Supply voltage

- Non-Ex and EEx-d instrument 20 ... 72 V DC, 20 ... 253 V AC, 50/60 Hz

Max. power consumption 4 VA; 2.1 W

Electrical protective measures

Protection

- Plastic housing IP 66/IP 67
- Double chamber Alu-housing, four-wire instruments IP 66/IP 67
- Alu and stainless steel housing, two-wire instruments IP 66/IP 68 (0.2 bar)⁴⁾

Overvoltage category III

⁴⁾ A suitable cable is the prerequisite for maintaining the protection class.

Protection class	
– two-wire, Profibus PA, Foundation Fieldbus	II
– four-wire	I

Approvals⁵⁾

VEGAFLEX 61, 62	
ATEX	ATEX II 1G, 1/2G, 2G EEx ia IIC T6 ATEX II 1/2G, 2G EEx d ia IIC T6, ATEX II 1/2D IP66 T, WHG
FM	FM Cl.I, Div 2 (NI) + Cl.II, III, Div 1 (DIP) FM Cl.I-III, Div 1 (IS) FM Cl.I-III, Div 1 (IS) + Cl.I-III, Div 1 Gr.C-G(XP)
CSA	CSA Cl.I, Div 2 (NI) + Cl.II, III, Div 1 (DIP) CSA Cl.I-III, Div 1 (IS) CSA Cl.I-III, Div 1 (IS) + Cl.I-III, Div 1 Gr.C-G(XP)
Ship approvals	
VEGAFLEX 66	
ATEX	ATEX II 1G, 1/2G, 2G EEx ia IIC T6 ATEX II 1/2G, 2G EExd ia IIC T6
FM	FM Cl.I, Div 2 (NI) + Cl.II, III, Div 1 (DIP) FM Cl.I-III, Div 1 (IS) FM Cl.I-III, Div 1 (IS) + Cl.I-III, Div 1 Gr.C-G(XP)

CE conformity

EMVG (89/336/EWG), Emission: EN 61326: 1997 (class B),
Susceptibility: EN 61326: 1997/A1: 1998
LVD (73/23/EWG), EN 61010-1: 2001
NAMUR recommendation NE 21

Functional safety (SIL)

You can find detailed information in the Safety Manual of VEGAFLEX or under www.vega.com.
Functional safety according to IEC 61508/IEC 61511
– Single channel architecture (1oo1D) up to SIL2
– Multiple channel architecture see "Safety Manual"

Environmental instructions

VEGA environment management system certified according to DIN EN ISO 14001
You can find detailed information under www.vega.com.

⁵⁾ Deviating data in Ex applications: see separate safety instructions.

7 Dimensions

Housing in protection IP 66/IP 67 and IP 66/IP 68; 0.2 bar

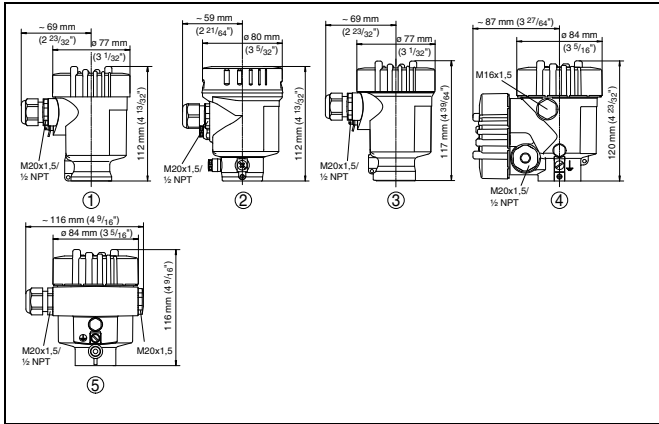

Fig. 25: Housing versions in protection IP 66/IP 67 and IP 66/IP 68, 0.2 bar (with integrated indicating and adjustment module the housing height increases by 9 mm/0.35 in)

- 1 Plastic housing
- 2 Stainless steel housing
- 3 Stainless steel housing - precision casting
- 4 Aluminium double chamber housing
- 5 Aluminium housing

VEGAFLEX 61 - cable and rod version

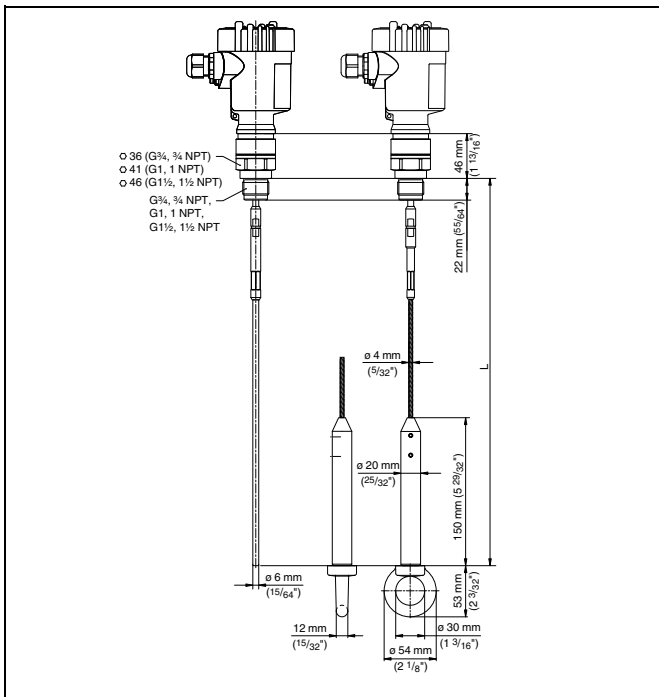

Fig. 26: VEGAFLEX 61 - cable and rod version with thread

L Sensor length, see chapter "Technical data"

VEGAFLEX 61 - cable and rod version with double chamber housing

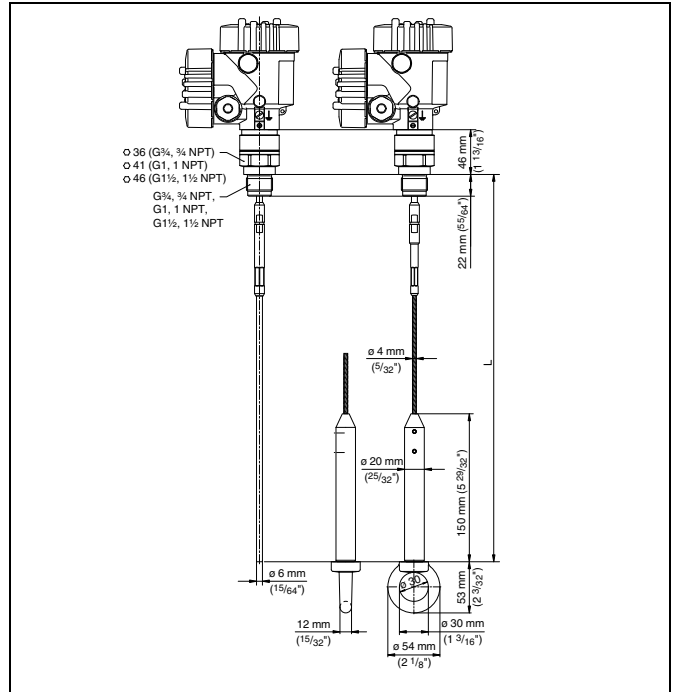

Fig. 27: VEGAFLEX 61 in cable and rod version with thread (double chamber housing)

L Sensor length, see chapter "Technical data"

VEGAFLEX 62 - cable and rod version

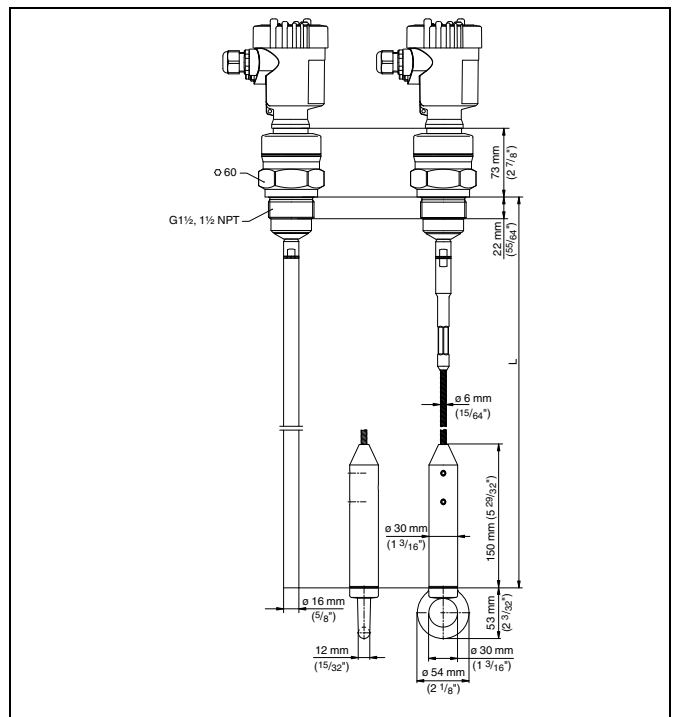

Fig. 28: VEGAFLEX 62 - cable and rod version with thread

L Sensor length, see chapter "Technical data"

VEGAFLEX 62 - cable and rod version with double chamber housing

VEGAFLEX 66 - cable, rod version (-200 ... +400 °C/-328 ... +752 °F)

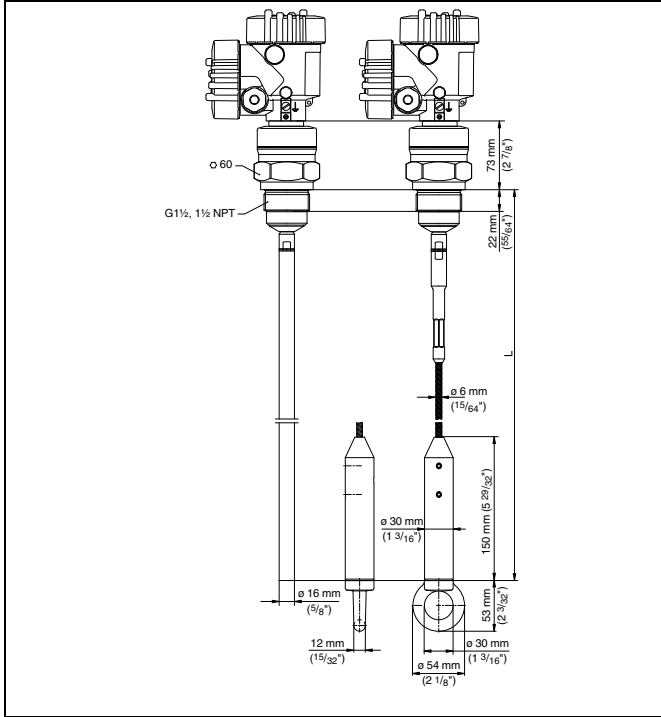

Fig. 29: VEGAFLEX 62 - cable and rod version with thread (double chamber housing)

L Sensor length, see chapter "Technical data"

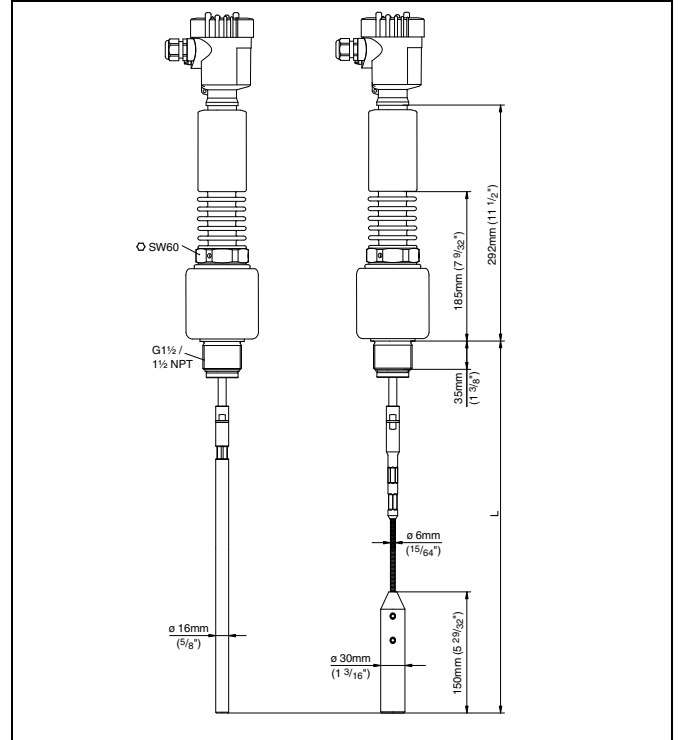

Fig. 30: VEGAFLEX 66 - cable, rod version (-200 ... +400 °C/-328 ... +752 °F)

L Sensor length, see chapter "Technical data"

VEGAFLEX 66 - cable, rod version with double chamber housing (-200 ... +400 °C/-328 ... +752 °F)

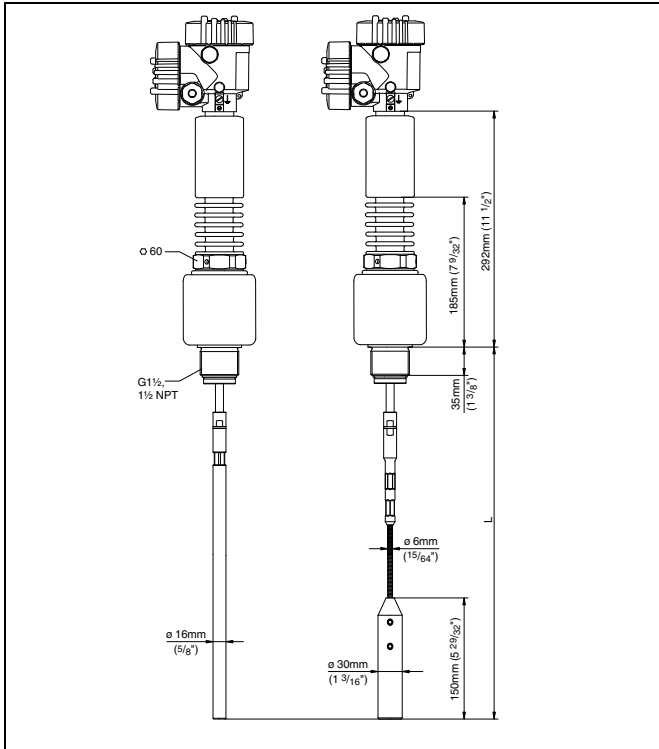
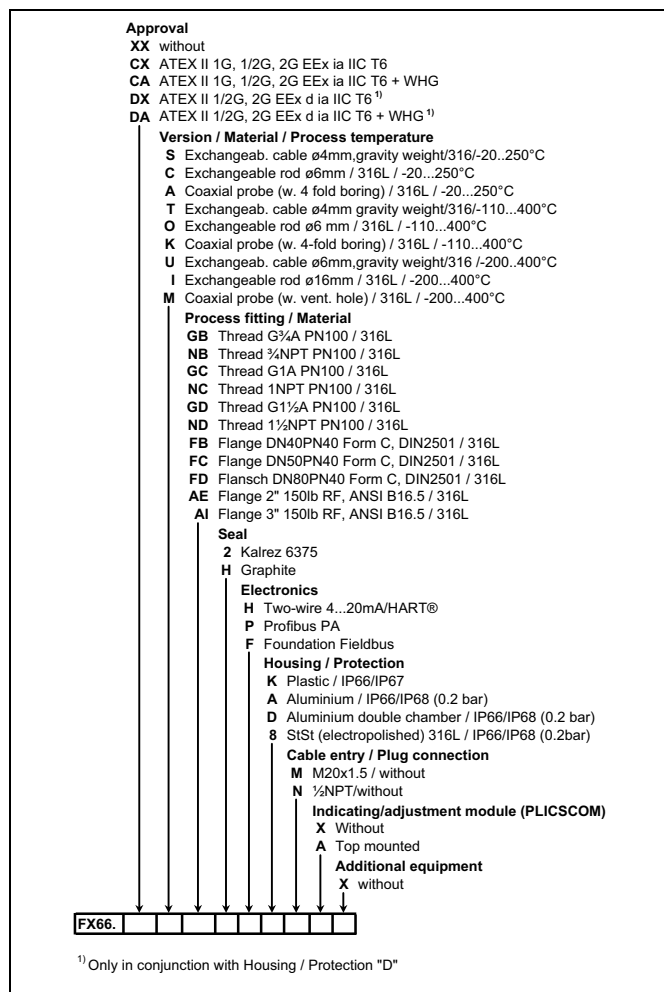
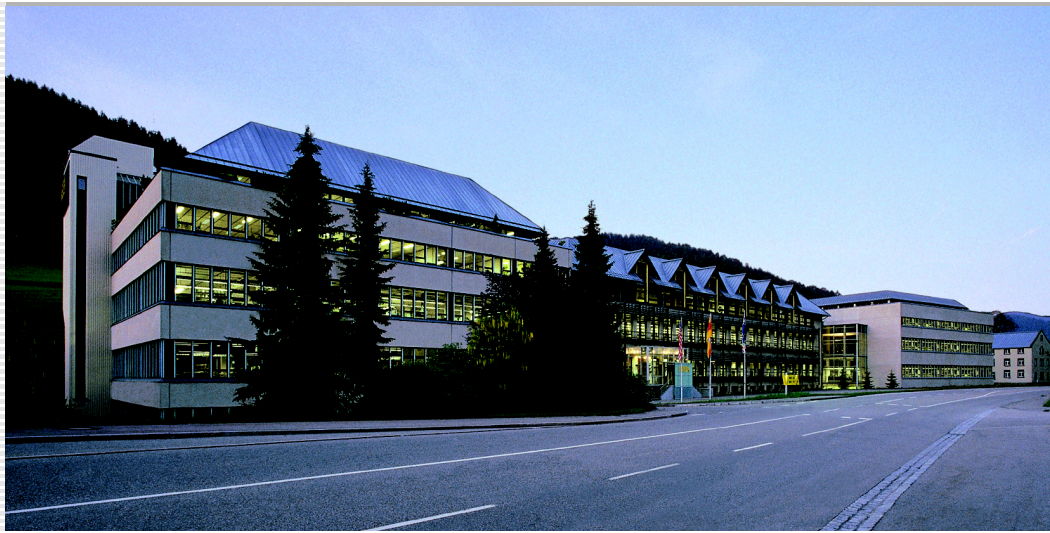

Fig. 31: VEGAFLEX 66 - cable, rod version (-200 ... +400 °C/-328 ... +752 °F) - double chamber housing

L Sensor length, see chapter "Technical data"

VEGAFLEX 66





VEGA

VEGA Grieshaber KG
Am Hohenstein 113
77761 Schiltach
Germany
Phone +49 7836 50-0
Fax +49 7836 50-201
E-Mail: info@de.vega.com
www.vega.com



You can find at www.vega.com downloads of the following

- operating instructions manuals
- menu schematics
- software
- certificates
- approvals

and much, much more