

FREQUENCY INVERTER

POSIDRIVE®

FDS 4000

Installation and Commissioning Instructions

It is essential to read and comply with these instructions prior to installation and commissioning.

MANAGEMENTSYSTEM



certified by DQS according to
DIN EN ISO 9001, DIN EN ISO 14001
Reg-No. 000780 UM/QM



POSITIONING CONTROL

VECTOR CONTROL

**SYNCHRONOUS
OPERATION**

TECHNOLOGY

SV. 4.5

GB 07/2003



Table of Contents

1. Notes on Safety	1		
2. Technical Specifications	2		
3. Physical Installation	3		
3.1 Installation Site	3		
4. Electrical Installation	3		
4.1 EMC-Compatible Installation	4		
4.2 FI Circuit Breaker	4		
4.3 DC Link Coupling	4		
5. Conn. Assignment - Control Portion	5		
6. Inverter Exchange, Compatibility	6		
6.1 Option Boards EA4000, GB4000	6		
6.2 FDS 1000, 2000	6		
7. Operator Control and Programming	6		
7.1 Status Indication	6		
7.2 Parameterization	6		
7.3 Password	7		
8. Commissioning	7		
8.1 Primary Parameters	7		
8.2 Motor Type	7		
8.3 Reference Value via Keyboard	8		
8.4 Analog / Frequency Reference Value	8		
8.5 Fixed Ref. Values (Digital Ref. Values)	8		
8.6 Brake Control	8		
8.7 Parameter Transmission	9		
9. Special Functions	9		
9.1 Binary Inputs BE1 to BE5 (BE6 to BE10)	9		
9.2 Torque Limits	9		
9.3 Operating Range	9		
9.4 Parameter Record Selection	10		
9.5 Motor Potentiometer	10		
9.6 Speed Feedback	10		
9.7 Acknowledgment of Faults	11		
9.8 Motor Startup	11		
9.9 Control via PC	11		
10. Positioning Control	12		
10.1 Function Overview	12		
10.2 Connections	12		
10.3 Destination Positioning and Proc. Blocks	13		
10.4 Absolute / Relative Positioning	14		
10.5 Commissioning	14		
10.5.1 Limited Traversing Range	14		
10.5.2 Continuous Trav. Range (Rotary Axis)	15		
10.6 Reference Point Traversing	15		
10.7 Position Controller	16		
10.8 Process Block Chaining	16		
10.9 Simple Examples	17		
10.10 Emergency Off	18		
10.11 Ext. Rotary / Linear Path Measurement	19		
		10.11.1 Encoder	19
		10.11.2 Adjustment of Motor / Ext. Meas. System	19
		10.11.3 External Encoder and Posi Parameters	19
		10.12 Posi Switching Points	20
		11. Technology	20
		11.1 PID Controller	20
		11.2 Winders	21
		11.2.1 Diameter Sensor on AE1/AE2	21
		11.2.2 Indirect Tension Control at M-Max Limit	21
		11.2.3 Winding with Compensating Roller	22
		11.2.4 Winding with Tension Sensor	22
		11.2.5 Compensation of Fault Variables	22
		12. Synchronous Running, El. Gearbox	22
		12.1 Function Overview	22
		12.2 Connection of Encoder	23
		12.3 Connection of Inputs and Outputs	23
		12.4 Commissioning of Slave	23
		12.5 Angle Deviation	24
		12.6 Angle and Speed Sync. Running	24
		12.7 Emergency Off	24
		12.8 Reference Point Traversing - Slave	24
		13. Parameter Description	25
		14. Option Boards	55
		14.1 Option Board GB4001 and EA4001	55
		14.2 Option Board Ext. 24 V Power Supply	56
		14.3 Option Board SSI-4000	57
		15. Result Table	58
		16. Operating States	59
		17. Faults/Events	60
		18. Block Circuit Diagram - Sync. Running	62
		19. Block Circuit Diagram - Ref. Val. Proc.	63
		20. Parameter Table	64
		21. Accessories	67
		21.1 Accessories Overview	67
		21.2 Braking Resistor	70
		21.2.1 Allocation of Braking Resistor to FBS/FDS	70
		21.2.2 Braking Resistor FZM/FZZM (Dimensions)	70
		21.2.3 Braking Resistor VHPR (Dimensions)	71
		21.3 Output Derating / Output Filter	71
		21.3.1 Allocation of Output Derating / Output Filter to FBS/FDS	71
		21.3.2 Output Derating RU (Dimensions)	71
		21.3.3 Output Filter MF (Dimensions)	71

1. Notes on Safety

1 NOTES ON SAFETY



To prevent avoidable problems from occurring during commissioning and/or operation, it is essential to read and comply with this entire instruction manual before starting installation and commissioning.

Based on DIN EN 50178 (once VDE 0160), FBS/FDS-series frequency inverters are defined as electronic power equipment (BLE) for the control of power flow in high-voltage systems. They are designed exclusively to power three-phase-current, asynchronous machines. Handling, installation, operation and maintenance must be performed in accordance with valid and/or legal regulations, applicable standards and this technical documentation.

The frequency inverter are products of the restricted sales class (in accordance with IEC 61800-3. Use of this products in residential areas may cause high-frequency interference in which case the user may be ordered to take suitable measures.

The user must ensure strict adherence to these standards.

The safety notes and specifications stated in additional sections (items) must be adhered to by the user.



Caution! High touch voltage! Danger of electric shock! Danger of death!

Never under any circumstances may the housing be left open or connections disconnected when the power is on. Disconnect the power plug of the frequency inverter and wait at least 5 minutes after the power voltage has been switched off before opening the frequency inverter to install or remove option boards. Correct configuration and installation of the inverter drive are prerequisites to correct operation of the frequency inverter. Only appropriately qualified personnel may transport, install, commission and operate this device.

Pay particular attention to the following:

- Permissible protection class: Protective ground; operation only permitted when protective conductor is correctly connected. The devices may not be operated directly on IT networks.
- Installation work may only be performed in a voltage-free state. When work has to be done on the drive, inhibit the enable and disconnect the complete drive from the power network. Adhere to the 5 safety regulations.
- Discharge time of the DC link capacitors > 5 minutes
- Do not penetrate the interior of the device with any kind of object.
- When performing installation or other work in the switching cabinet, protect the device against falling objects (e.g., pieces of wire, flexible leads, metal parts and so on). Conductive parts may cause short circuiting or device failure on the frequency inverter.
- Before commissioning, remove all extra coverings to prevent the device from overheating.

The frequency inverter must be installed in a switching cabinet which does not exceed the maximum ambient temperature (see technical data).

Only copper wiring may be used. For use in the U.S.A., see table 310-16 of the National Electrical Code (NEC) for line cross sections to be used at 60 °C or 75 °C.

STÖBER ANTRIEBSTECHNIK accepts no liability for damages caused by non-adherence to the instructions or applicable regulations.

The motor must have an integral temperature monitoring device or external motor overload protection must be used.

Only suitable for use on power networks which cannot supply more than a symmetric, nominal short-circuit current of 5000 A at 240 V ac / 480 V ac.

Notes:

Subject to technical changes for improvement of the devices without prior notice. This documentation is solely a product description. It is not a promise of features in the sense of warranty rights.

2. Technical Specifications

Model	Model 1 / BG I				Model 2 / BG II				Model 3 / BG III					
	FBS 4008/B	FBS 4013/B	FDS 4014/B	FBS 4024/B*	FBS 4028/B*	FDS 4040/B*	FDS 4070/B*	FDS 4085/B*	FDS 4110/B*	FDS 4150/B*	FDS 4220/B*	FDS 4270/B*	FDS 4300/B*	
Type of device														
Recommended motor power ¹⁾	0.37 kW	0.75 kW	0.75 kW	1.5 kW	1.5 kW	2.2 kW	4.0 kW	5.5 kW	7.5 kW	11 kW	15 kW	18.5 kW	22 kW	
Nominal current I _N ²⁾	3 x 2.1 A	3 x 3.5 A	3 x 2.1 A	3 x 3.5 A	3 x 7.0 A	3 x 5.5 A	3 x 10 A	3 x 12 A	3 x 16 A	3 x 22 A	3 x 32 A	3 x 39 A	3 x 44 A	
Connection voltage	(L1-N) 1 x 230 V +20%/-55% ⁴⁾ / 50/60 Hz	(L1-L3) 3 x 400 V +28%/-55% ⁴⁾ / 50/60 Hz	(L1-L3) 3 x 400 V +28%/-55% ⁴⁾ / 50/60 Hz	see FBS / BGI	see FBS / BGI	(L1-L3) 3 x 400 V +28%/-55% ⁴⁾ / 50/60 Hz								
Power fuses ⁵⁾	1 x 6 AT	1 x 10 AT	3 x 6 AT	1 x 16 AT	3 x 10 AT	3 x 16 AT	3 x 20 AT	3 x 25 AT	3 x 35 AT	3 x 50 AT	3 x 50 AT	3 x 50 AT	3 x 63 AT	
Output voltage	3 x 0 V up to connection voltage													
Output frequency	0 - 200 Hz (vector control: 0 - 100 Hz; spindles: 0 - 400 Hz at B20 =0V/f-control and B24 =8 kHz) / resolution of 0.01 Hz													
I _{max}	200 % / 2 sec , 150 % / 30 sec													
Clock pulse frequency	4 kHz (adjustable up to 16 kHz with current derating of 46% at 16 kHz, 75% at 8 kHz)													
Braking resistance, limit data, brake chopper)	≥ 100 Ω; max. 320 W const., max. 1.8 kW für 1 s	≥ 200 Ω; max. 640 W const., max. 3.2 kW für 1 s	≥ 100 Ω; max. 1.28 kW const., max. 6.4 kW für 0.5 s	≥ 30 Ω; max. 21 kW const.,										
RFI suppression ³⁾	Integrated network filter for compliance with RFI suppression in acc. w. EN 55011, classes A + B/residential and industrial zoning													
Interference immunity	EN 61000 -4 -2, -3, -4, -5/residential and industrial zoning													
Permissible length of motor cable, shielded	50 m, proportionately shorter when several motors are used. Longer lengths or parallel installation to encoder cable with output derating.													
Ambient temperature	0° to 45° C for nominal data Up to 55° C with power reduction of 2.5% /° C													
Storage temperature	-20 °C to +70 °C, Max. change, 20 K/h													
Humidity during operation	Relative humidity of 85%, no condensation													
Power loss	36 W	53 W	50 W	77 W	100 W	88 W	150 W	180 W	220 W	290 W	420 W	500 W	550 W	
Protection rating	IP 20													
Dimensions W x H x D (in mm)	98 x 300 x 176				98 x 300 x 268				186 x 410 x 268					
Core cross section (in mm ²) Motor cable/power cable	max. 2.5													
Weight (in kg) - without packing - with packing	3.2 4.3	5 6.4	12.3 14.5	12.4 14.6	13 15	12.8 15	13 15.2	13.2 15.4						

* = Externally ventilated (integrated fan)
¹⁾ For nominal connection voltage, clock pulse frequency 4 kHz, 4-pin asynchronous machine, motor cable shielded 50 m
²⁾ With S1, clock pulse frequency 4 kHz
³⁾ Clock pulse frequency 4 kHz, motor cable shielded and applied on both sides
⁴⁾ Power networks ≠ 400 V; Low voltage limit (A35) and A36 may have to be adjusted.
⁵⁾ Line circuit breaker - tripping characteristic D in accordance with EN 60898
 For UL conformity, use class RK1 fuses: 1~: **Bussmann KTN-R** (200 to 240 V) 3~: **Bussmann KTS-R** (380 to 500 V)

3. Physical Installation
4. Electrical Installation

3 PHYSICAL INSTALLATION

Dimension in mm			BG I	BG II	BG III	
Frequency inverter, base plate	Height	h	300	300	410	
	Width	w	98	98	186	
	Depth	d1	176	268	268	
d2		158	250	250		
Base plate, mounting holes	Vertical	a	282,5	282,5	392,5	
		Horizontal	above	---	---	150
			below	b	70	70
Min. free space between adjacent units			Top/bottom: 100 (min.) Right/left: 1 (min.)			
Screws			M5			

d1 = Device depth including plug connector

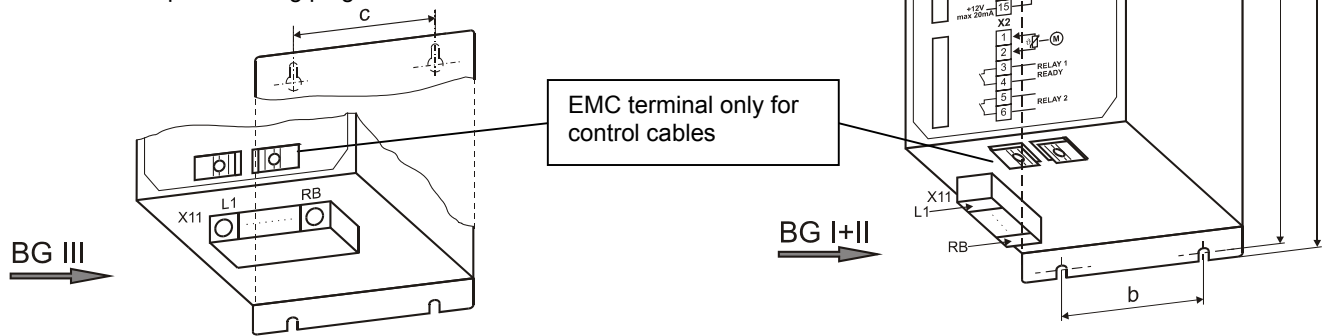

3.1 Installation site

- Operate only in closed switching cabinet.
- Install inverter only in vertical position.
- Avoid installation over heat-producing devices.
- Ensure sufficient air circulation in switching cabinet. (Minimum free space of 100 mm over and under the device!).
- Keep installation site free of dust, corrosive fumes and all liquids (in accordance with soil degree 2 in accord. with EN 60204/EN 50178).
- Avoid atmospheric humidity.
- Avoid condensation (e.g., by anti-condensation heaters).
- Use unpainted mounting plates with conductive surface (e.g., unpainted) to conform with EMC regulations.

4 ELECTRICAL INSTALLATION

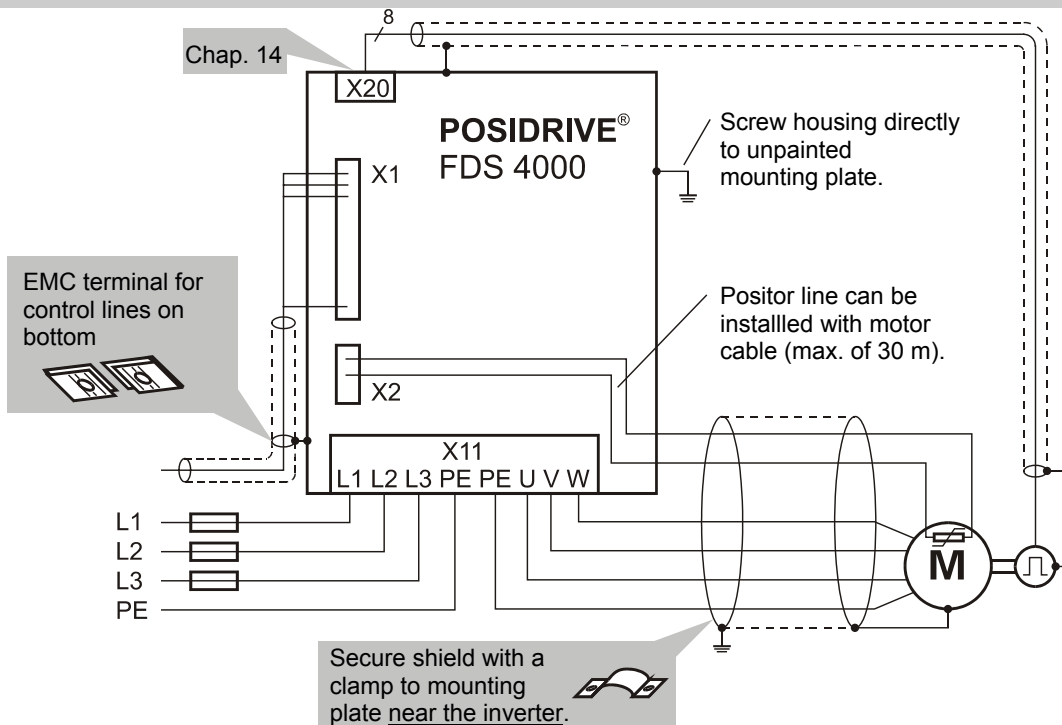

4. Electrical Installation

	Terminal Designation		Function	Circuiting
	FBS	FDS		
Power section X11	--	L1	Power connection: FBS L1 – N: 1 x 230 V +20% / -55% 50/60 Hz	Single-phase connection (FBS) X11
	L1	L2	FDS L1 – L3: 3 x 400 V +28% / -55% 50/60 Hz	
	N	L3		
	PE		Protective conductor, power	Three-phase connection (FDS) X11
	PE		Protective conductor, motor/motor cable shield under FDS on mounting plate (see page 3)	
	U		Motor connection U, V, W	
	V		Adhere to sequence	
	W			
	R1 (+R)		Conn. of ext. braking resis. ⇒ Activation by A20 required DC link potential (+)	Shield connection: See page 3.
	R2 (R)		With the external brake resistor, we recommend using types with integrated overcurrent relays to prevent thermal damage caused by overload.	
U-		DC link potential (-), see remarks		

* Remarks: Plug connector for DC link available as accessory (see chap. 22). Not available for 1 ~ FBS, BG I

4.1 EMC-Compatible installation

Basic rules

- Install control and power cables separately (> 20 cm).
- Install power, encoder and motor cables in separate spaces.
- Central grounding point in immediate vicinity of the inverter. All shields and protective conductors of motor and power cables are applied here over a large area.
- Reference value cables must be shielded and, if necessary, twisted in pairs.
- Connect shield of control lines on one side to the reference ground of the reference value source (PLC, controller, etc.).

Motor cable

- Use shielded cables. Apply shield on both sides.
- Use motor derating when cables are longer than 50 m.
- Motor derating is recommended when cables are installed parallel to encoder lines.

FDS	Power Fuse	Max. Drive Power
BG1	3 x 10 AT	4.0 kW
BG2	3 x 20 AT	8.5 kW
BG3	3 x 63 AT	30 kW

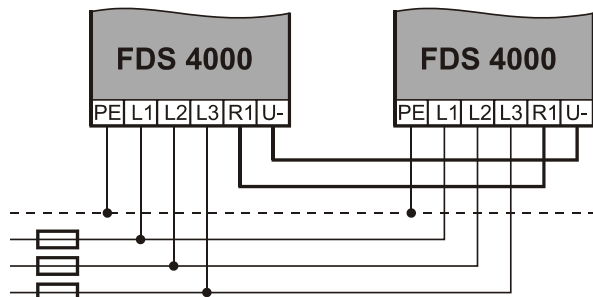

4.2 FI circuit breaker

Network phases and directly grounded conductor are connected to the protective conductor with Y capacitors. When voltage is present, a leakage current flows over these capacitors to the protective conductor. The greatest leakage current is created when a malfunction occurs (asymmetric feeding over only one phase) and power-on (sudden change in voltage). The maximum leakage current caused by asymmetric powering is 18 mA for FDS inverters (power voltage of 400 V). In connection with frequency inverters, only universal-current-sensitive, fault current circuit breakers may be used if the application permits tripping current with increased tripping current (e.g., 300 mA) or selective circuit breakers (switch-off delay). Use of several devices on one FI circuit breaker is not recommended.

Coupling of devices of differing design:

Each device has its own power fuse based on its technical specifications (chap. 2). In addition, each device must be protected on the DC link in R1 (U+) and U- with the same current strength. The fuse must be suitable for a voltage of 500 V DC. Lines with lengths of 20 cm and longer must be shielded.

Brake resistor: Only connect to one device (the largest).

4.3 DC link coupling

Coupling of devices of the same design:

All coupled devices must be connected to one common power fuse. The following table shows you which fuse to select. Maximum possible drive power is limited by the common fuse. If more power is required, proceed as for coupling devices of differing design.

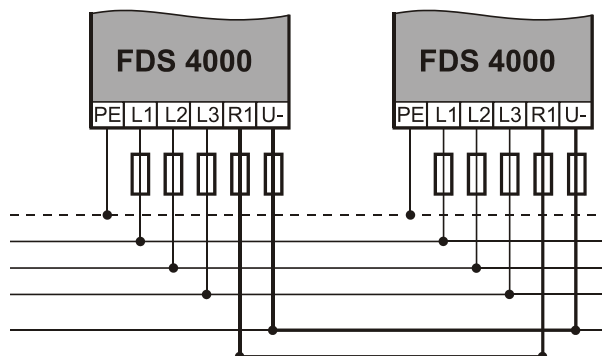

5. Connection Assignment - Control Portion

	Term.	Function	Circuiting		
Control terminal strip X1	A (+)	Analog input AE2 0 to ±10 V	AE2 function can be programmed under F20		
	B (-)	R _i = 25 kΩ, 10bits+sign T _a = 4 msec			
	1	Internal voltage supply +10 V ±5%, max 3 mA	<i>External voltage</i>	<i>External current</i>	<i>Potentiometer</i>
	2 (+)	Analog input AE1 0 to ±10 V R _i = 25 kΩ, 10bits+sign T _a = 4 msec			
	3	Analog input current 0 to ±20 mA R _i = 510 Ω, 10bits+sign			
	4 (-)	Analog input AE1, inverted	AE1 function can be programmed under F25 .		
	5	Analog output 0 to ±10 V, R _i = 1 kΩ 10bits+sign, T _a = 4 msec	Function can be programmed under F40 . Time constant, low pass, 10 msec		
	6	Analog ground	Reference potential for terminals A, B and X1.1 to X1.5		
	7	Ground 12 V	Reference potential for terminal X1.15		Tech. data of binary inputs: L level: < +8 V H level: >= +12 V Voltage limits: -10 V to +32 V Interference immunity EN 61000-4 Important: With ext. 24 V addressing, do not insert jumper between X1.7 and X1.8. Connect external ground to X1.8.
	8	Digital ground	Reference potential for inputs X1.9 - X1.14		
	9	Enable T _a = 4 msec	Enable power section. See also param. F38 . Consider halt magnetization (B25 , F00 =22).		
	10	Input BE 1 * 8:halt	Freely programmable, floating inputs. Function is specified with parameters F31 to F35 . Scan time T _a = 4 msec. If an incremental encoder is used, max. input frequency on BE4 to BE5 is 80 kHz. With certain positioning functions (e.g., <i>Posi:next</i>) BE3 is <u>without delay</u> . * Default setting of the inverter		
	11	Input BE 2 * 6:Direction of rotation			
	12	Input BE 3 * 1:RV-select0			
	13	Input BE 4 * 2:RV-select1			
14	Input BE 5 * 0:inactive				
15	Internal voltage source ¹ 12 V, 20 mA	Can be used to address binary inputs X1.9 to X1.14. If so, reference ground of the binary inputs (X1.8) must be jumpered with 12 V ground (X1.7).			
Terminal strip X2	1	Motor	Connection for one to six positor lines (thermal motor protection). Lines can be installed with the motor cable up to 30 m. If positor lines are not used with a motor, terminals X2.1 to X2.2 must be jumpered.		
	2	- Temperature sensor (PTC) - Thermal contact (3.2 V, 1 mA max.)			
	3	Relay 1 max. 6 A/250 V AC 6 A/30 V DC ohm. load 1 A/30 V DC ind. load, switching time 15 msec T _a = 4 msec	Indicates that frequency inverter is ready for operation (i.e., relays closed) Function can be programmed with F10 . Life expectancy (no. of switches): Physical: min. of 10,000,000 times 100 000 times at 250 V AC, 6 A 300 000 times at 30 V DC, 2 A (ohm. load) More frequent signal change → Use optional binary outputs!		
	4	Relay 2 (=BA2)	Additional relay output, (e.g., for brake control)		
	5	Same tech. spec. as relay 1	Function can be programmed with F00 (= F81).		
	6	T _a = 4 msec	For brake control, see chap. 8.6.		

Remarks: T_a = Scan time
VZ = Sign

¹ Short circuit resistance. Caution: A short circuit may cause a processor reset.

6. Inverter Exchange, Compatibility
7. Operator Control and Programming

6 INVERTER EXCHANGE, COMPATIBILITY

6.1 Option boards EA4000, GB4000

The following information applies when old boards (EA4000 and GB4000) are replaced by new boards (EA4001 and GB4001) (see chap. 14.1) or when inverters with these boards are replaced.

FDS software and hardware version (parameter E51)

- New EA4001 and GB4001 option boards will not run on old devices. New option boards require software and hardware release 4.5 or later.
- Old EA4000 and GB4000 option boards will also run with newer software (4.5 or later).

Encoder connection HTL (EA4000 + GB4000)

- Old: Inverted encoder tracks remain free.
- New: Inverted tracks must be connected.

Encoder connection TTL (EA4000 + GB4000)

- Old: Direct connection to the terminals
- New: The terminating resistance must be adjusted with sliding switch.

Encoder power, TTL encoder (EA4000 + GB4000)

- Old: Can be switched between 5 V and 16 V
- New: **Fixed at 18 V.** Cannot be switched!
Encoders that are suitable for a voltage of 18 V must be used. An external 5 V powerpack can be used as an alternative.

Plug connector X21 for EA4000 (chap. 14.1)

- Old: 7 terminals
- New: 9 terminals ("A" and "B" are new.)
The right-hand portion (terminals 1 to 7) remains unchanged. Terminals A and B remain free.

Parameterization

- Old: **F39** for X20 increments
- New: **H22** for X20 increments, **H20** for X20 function

6.2 FDS 1000, 2000

Before replacing devices, please request detailed instructions from STÖBER Service.

7 OPERATOR CONTR. AND PROGRAMMING

7.1 Status indication

In its default setting, the display is set up as shown below.

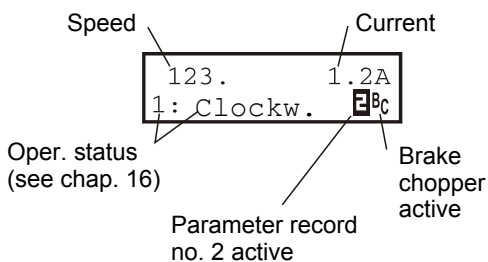

All possible operational states are listed in chapter 16. If **B** is lit up, this means that the inverter is using parameter record no. 2. If parameter record no. 1 is active (default setting), no special indication is made. **Bc** appears when the brake chopper is activated.

C51 can be used to convert the speed (e.g., to gear output). In control mode V/f control (**B20=0**) and sensorless vector

(**B20=1**), the post ramp reference value is indicated as the speed for vector control with speed feedback (**B20=2**) of the actual speed measured.

The first line of the display can also be customized. A function selected via **C50** (e.g., power) is divided by **C51** and provided with the unit in **C53** (e.g., "items/min"). The unit can only be specified via FDS Tool. The number of positions after the decimal point is provided by **C52**.

In position mode (**C60=2**), the position is shown in the first line when speed feedback is present. The second line indicates the operational status.

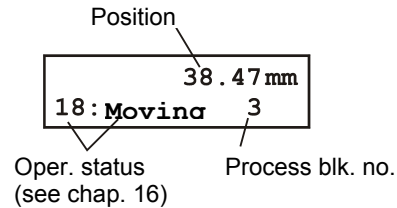

7.2 Parameterization

- Return to prev. menu level
- Reject changes
- Acknowledgement of mal-functions (**A31=1**)
- Select various menu levels
- Accept changes

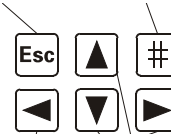

- Group selection
- Parameter selection
- Edit parameters

To program, press the **#** key (Enter). The menu consists of several **groups** which are identified with the letters **A, B, C** and so on. Select the groups with the arrow keys (i.e., **◀** and **▶**). Press the **#** key again to access the parameters of the selected group.

The parameters are designated with the group letters and a number (e.g., **A10** or **D02**).

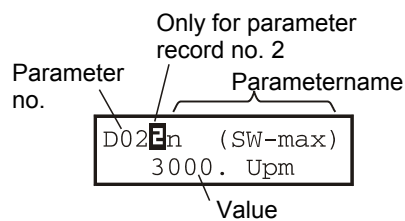

Parameters are selected with the **▲** and **▼** keys. To change a parameter, press the **#** key again. The flashing value can now be edited with **▲** and **▼**. The changes take effect immediately. To retain the changed value, press the **#** key. To reject the change, press the **Esc** key. To return from parameter selection to the group letters, press **Esc**. To return to the status display, press **Esc** again.

Parameter changes must be saved with A00=1 (save parameters) before the device is turned off.

8. Commissioning

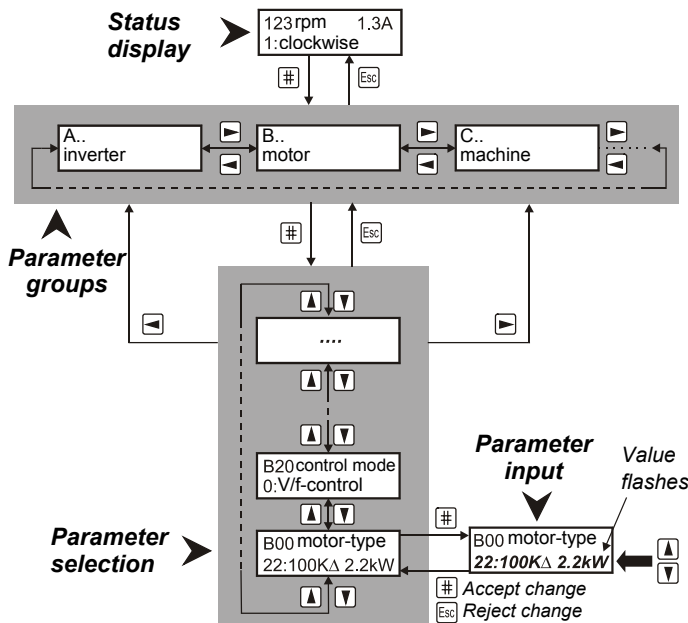

After power-on, the inverter only shows the most important parameters which are required for commissioning. The *extended menu level* is activated with **A10=1** for the solution of complex drive tasks.

A10=2:service; Access to rarely used service parameters

Both the normal menu and the expanded menu do not show parameters which are not related to the current task.

Example: When a predefined STÖBER motor (e.g., 100KΔ2.2kW) is selected in parameter **B00** (motor type), parameters **B10** to **B16** (poles to cos PHI) are not shown.

Approximately 50 sec after the last key was pressed, the device returns automatically to the status display. This return can be prevented with **A15=0** (auto return inactive).

Fieldbus: Most of the parameters pertaining to the fieldbus can only be set on the PC with FDS Tool.

7.3 Password

The parameters can be protected against unauthorized change. To do this, enter a password (an up to 4-digit number but not zero) in parameter **A14**, and save it with **A00=1**. Password protection is inactive if **A14=0**. Parameter **A14** can only be accessed in the extended menu with **A10=1**. On a protected device, the parameters can only be changed after the correct password has been entered in **A13**.

8 COMMISSIONING

The power connections (i.e., power supply and motor) must first be correctly wired in accordance with chap. 4. Before initial commissioning with a reference value potentiometer, the following circuiting must be made:

- Reference value specification via potentiometer (X1.2 - X1.4). See chap. 5.
- Enable (terminal X1.9)
- Temperature sensor (terminals X2.1 and X2.2). See chap. 5.

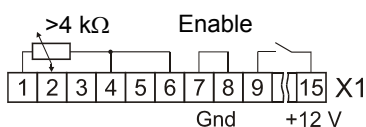

If no temperature sensor exists, X2.1 and X2.2 must be jumpered. The internal 12 V voltage on X1.15 can be used to power the control signals. This requires a jumper between X1.7 and X1.8. Motor and inverter must be adjusted to each other. To do this, select the appropriate motor type in parameter **B00**. See chap. 8.2.

8.1 Primary parameters

When connected to the power supply, the status display shows status "0:Ready for operation." If "12:Inhibited" is shown instead, the enable must be removed. The following parameters must then be specified.

- **A20:** (braking resistor type) if present
- **B00:** (motor type stated on nameplate). See chapter 8.2.
- **B20:** (control mode) can usually be left at "1:Sensorless Vector." Speed accuracy and dynamics are better here than classic V/f control (**B20=0**). For vector control with n feedback, see chapter 9.6.
- **C00:** (min. speed), **C01** (max. speed)
- **D00, D01:** Acceleration and deceleration ramp
- **D02:** Speed at 100% reference value (10 V on AE1)

"Check entries" is started with **A02=1**. Any contradictions in the parameterization are reported.

⇒ Remember to save the parameters with **A00=1** before turning off the power.

8.2 Motor type

Most 4-pole STÖBER motors can be specified directly in the **B00** parameter:

Example: For drive C613_0630 D100K 4 TF (100 K, 4-pole motor), either "17:100KY2.2kW" or "18:100KD2.2kW" is entered in **B00** depending on the circuiting (i.e., star or delta).

⇒ When a concrete motor type is specified, no further settings (e.g., break point, nominal current and similar) are necessary.

The following applies to STÖBER motors up to a size of 112 (i.e., 4 kW):

With the star connection (i.e., Y), the nominal voltage is reached at 50 Hz, while with the delta connection (i.e., Δ) the nominal voltage is reached at 87 Hz. With the star connection, full motor torque is available up to 50 Hz, while with the delta connection full motor torque is available up to 87 Hz. The delta connection is used for motors starting with size 132. Full torque is available up to 50 Hz (with power connection 3 x 400 V / 50 Hz).

If motors are not predefined (e.g., motors of other manufacturers or the number of poles is not 4), **B00** must be set to "0:user defined." Parameters **B10** to **B16** must be set manually based on the motor's nameplate. FDS Tool has an **external motor data base** for non-Stöber, user-defined motors. Your own motors can be added to the motors which are predefined there.

B00=0 must be used for motors with special winding (e.g., motor 132 with 230/400 V). The V/f characteristic curve (i.e., the relationship between voltage and frequency) is specified by the parameters **B14** (nominal voltage) and **B15** (nominal frequency). Additional specification of the break point is not necessary. As the frequency rises, the voltage increases past **B14** up to the available power voltage or **A36**.

The motor must then be sized with **B41=1** as shown below. (Continue on next page.)

8. Commissioning

1. Set **B41**=1. Default display is 0%.
 2. Activate enable. Measuring begins.
 3. When 100% is reached, remove enable. Measurement is concluded.
- ⇒ Save parameters with **A00**=1 before turning off the power.
- ⇒ When the FDS-Tool is used, the edited parameters must be stored on the inverter before autotuning.

8.3 Reference value via keyboard

For a function test during commissioning, it is sufficient to connect enable input X1.9 and the terminals for temperature sensors X2.1 and X2.2. The speed is specified with the keyboard. Set **A50**=1 (tip active), and activate **A51** with **[#]** so that the speed reference value flashes. Speed **A51** is used until the next time **[#]** or **[Esc]** is pressed. The speed can be changed with **[▲]** and **[▼]**.

An alternate method when **A50**=1 is flashing (entry after **[#]**) is to use the **[←]** and **[→]** keys to move the drive (classical tip mode). The tipping speed can be adjusted with **A51** (set **A50**=0 beforehand or the drive will start running).

The frequency inverter can also be operated directly via Controlbox without extra circuiting. The device is enabled with the keys manual operation **[▲]** and ON **[I]**. You can then continue with the direction keys **[←]** and **[→]**. The tipping speed can also be adjusted here with **A51** (set **A50**=0 first, or the drive will start).

8.4 Analog/frequency reference value

With the default setting, the speed can be specified immediately via the reference value on analog input AE1 (e.g., via potentiometer, cf. chap. 5). The following parameters are important:

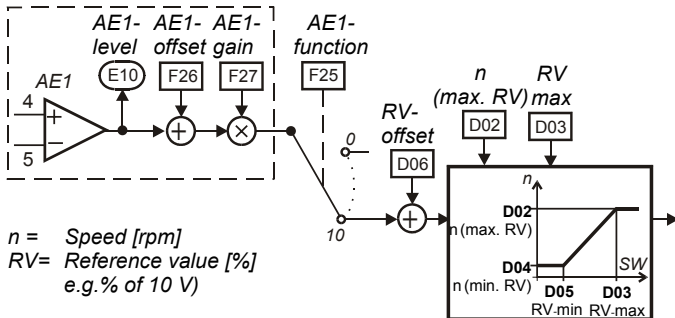

- **D02**: n (RV-Max) Speed at maximum reference value (10 V, 20 mA or f-max)
- **E10**: AE1 level Indication in % of the final value (final value=10 V or 20 mA)

With the extended menu (**A10**=1), the following parameters are also available.

- **D03**: refVal-Max. Maximum reference value in % of the final value (final value=10 V, 20 mA or f-max). For example, with **D03**=50%, the speed set in **D02** is achieved at 5 V or 10 mA.
- **D04**: n (RV-Min.) Speed at minimum reference value
- **D05**: refVal-Min. Minimum reference value in % of the final value
- **D06**: refVal-offset Offset on AE1 in % of the final value

Parameters **D02** to **D05** can be used to specify as desired the relationship between the analog reference value (usually the voltage) and the speed in the form of a reference value characteristic as shown below.

Possible reference values are voltage (100%=10 V), current (100 %=20 mA or frequency (f-max=100%=parameter **F37**). The **frequency reference value** is activated by **F35**=14. The frequency signal must be available on BE5. Frequency reference value and speed feedback cannot be used at the same time. The ramps for the analog and frequency reference value are specified by **D00** and **D01**. **D92**=1 negates the reference value. When **D07**=1, the controller enable depends on the reference value. See block circuit diagram of the reference value processing in chapter 19.

8.5 Fixed reference values (digital ref. val.)

Up to 7 fixed reference values (FRV) can be defined. Switchover is binary-coded via binary inputs. With the *default setting*, inputs BE3 and BE4 are provided for the selection of three fixed reference values.

BE4	BE3	Reference Value	E60	Ramps
L	L	Analog / frequency	0	D00,D01
L	H	Fixed ref. value 1, D12	1	D10,D11
H	L	Fixed ref. value 2, D22	2	D20,D21
H	H	Fixed ref. value 3, D32	3	D30,D31

The speed in **D12**, **D22**, etc. is entered in motor rpm. The input signals are fed to a reference value selector and binary decoded there. The result of the binary decoding (i.e., 0 to 7) is indicated in parameter **E60**.

- ⇒ If the result of binary decoding is 0 (**E60**=0, i.e., L level on all inputs of the RV selector), the analog/frequency reference value is also taken into consideration. The binary inputs can be allocated as desired to the input signals of the reference value selector. With the default setting, **F33**=1 (BE3 function=RV select0) and **F34**=2 (BE4 function=RV select1) apply. RV select0 and RV select1 correspond to bits 0 and 1 of the binary reference value selector. If no binary input is assigned to one of the three refVal select signals, this signal is considered low. To use all 7 fixed reference values, input BE5 could be programmed to **F35**=3 (RV select2), for example. The selected ref. value is negated with **D92**=1 (i.e., the direction of rotation is reversed). The fixed ref. value number can be specified directly with **D09**.

8.6 Brake control

Relay 2 is programmed with **F00**=1 for brake control. The brake is applied under the following conditions.

- Removal of the enable. Watch **F38**=1.
- Halt. One BE must be programmed to HALT (e.g., **F31**=8).
- Quick stop (e.g., with BE function "9:quick stop")
- Halt or quick stop with BE functions "clockwise V3.2" and "counter-clockwise V3.2" (both signals on "L" or "H")
- Fault. Watch **F38**=2.
- During specific process block positions. See group L..

The brake can be released manually with BE function "**32:brakeRelease**."

After release on, remember that halt magnetization must first be established (≤ 500 msec). The BA-function 22:RVready" is used to report the time of the halt magnetization.

During operation without speed feedback (i.e., **B20** < 2), **F01** and **F02** are used to define the speed limit to open and close the brakes.

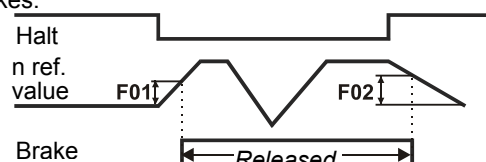

9. Special functions

With **vector control** (**B20=2**), **F00=1** can be used for full brake control in lifting systems. The release time **F06** and application time **F07** of the brakes must be specified with an additional amount for the relay delay time (10 to 30 msec). When one of the above events occurs, the drive remains controlled for the time **F07**. During traversing, startup is delayed by the time **F06**.

The magnetizing current can be turned off or reduced ("econo mode," parameter **B25**) when halt is active or when process-block-specific brake control is used during positioning.



24 V brakes may not be controlled directly with relay 2. Use an external auxiliary relay instead!

8.7 Parameter transmission

Using the **Parabox**, a **Controlbox** or the **FDS Tool** PC software, parameters can be transferred quickly between inverters or between inverter and a PC.

Write data to Parabox:

- Connect Parabox to sub D plug connector X3 of the first device.
- Values are written to Parabox with **A03=1**.



Read data from Parabox:

- Connect Parabox to the new device.
- Values are read from Parabox with **A01=1** and, at the same time, saved safe from power failures.
- **A40=1** reads Parabox without saving afterwards.

Controlbox offers memory space for the parameters of up to 7 devices. The inverter data are written to Controlbox as shown below.

- Select the memory space number (1 to 7) in **A03** (write Parabox).
- Press **[#]**.



The data are read from Controlbox to the inverter in a similar manner.

- Select memory space number with **[#]** in **A01** (read Parabox & save).
- There is no automatic saving with **A40** (read Parabox).

9 SPECIAL FUNCTIONS

9.1 Binary inputs BE1 to BE5 (BE6 to BE10)

With the default setting, the binary inputs which can be programmed as desired have the following meaning:

- BE1 = 8:Halt
- BE2 = 6:Direction of rotation (left/right)
- BE3 = 1:RV select0 (bit 0, fixed reference value decoding)
- BE4 = 2:RV select1 (bit 1, fixed reference value decoding)
- BE5 = 0:Inactive

The function of the binary inputs is specified via the parameters **F31** to **F35**.

Option board EA4001 offers five additional binary inputs. The function of the binary inputs is specified via the parameters **F60** to **F64** in the extended menu (**A10=1**).

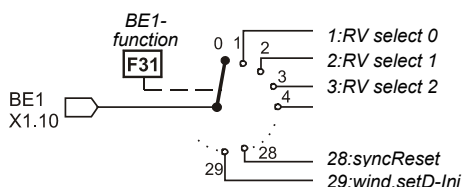

When several inputs are connected to one function, the signals are either AND or OR-linked (**F30** BE-logic). Functions

without a connection to a BE signal are internally given an L-level signal.

9.2 Torque limits

There are several methods of limiting motor torque.

- With the default setting, **C03** (M-Max 1) is the current torque limit in % of the nominal motor torque.
- A binary input (assign BE function "10:torque select" via one of the param. **F31** to **F35**) can be used to switch between the two torque limits **C03** (M-Max 1) and **C04** (M-Max 2).
- During startup mode **C20=2** (cycle characteristic), switching between **C03** (M-Max 1) and **C04** (M-Max 2) is automatic. M-Max 1 is used during constant travel, while M-Max 2 is used during acceleration phases.
- Analog input AE1 or AE2 can also be used to limit torque. Set parameter **F25=2** or **F20=2**. 10 V represent 100% of nominal motor torque. Other scaling factors can be set with **F22** (AE2-gain) or **F27**.
- **C04** (M-Max 2) always takes effect for a quick stop.

The actually effective torque limit is calculated from the minimum of the various limit values. It can be scanned in parameter **E62**.

- ⇒ Torque limitation is the most precise in speed feedback mode. Accuracy here is $\pm 5\%$ of nominal torque. In the classical control mode *V/f control* (parameter **B20=0**), torque calculation is not very accurate with low speeds and small loads. Results with control mode *Sensorless Vector Control* (**B20=1**, default setting) are better than with *V/f control*.

Particularly in control mode *Sensorless Vector Control*, the dynamics can be improved by estimating the ratio of inertia **C30** (J-mach/J-motor) and setting it accordingly. **C30=0** (default setting) applies if the driven inertia is low or if the gear ratio is high.

- ⇒ We all know that the relationship between current and torque is not easy to determine for asynchronous motors. Since an FDS inverter is able to calculate the torque from available measured data, the maximum torque is specified and not the maximum current. Maximum available torque is always limited by the maximum inverter current.

9.3 Operating range

Freely programmable comparators can be used to simultaneously monitor 3 measured values (i.e., "operating range"). The first 2 values (speed and torque) are fixed. The third value can be selected as desired with **C47**. The limit values are specified with the following parameters.

- **C41, C42**: n-Min, n-Max
- **C43, C44**: M-Min, M-Max
- **C45, C46**: Measured value "X" (specified in **C47**)

C48=1 monitors the absolute value of measured value "X" (**C47**). **C48=0** also includes the sign. Parameter **C49** specifies whether monitoring is also to take place during acceleration phases and enable-off. When at least one of the limits is exceeded, this can be signaled on a binary output with the "6:operation range" function (e.g., **F00=6**). Another use is the control of process-block chaining (cf. **J17=4**).

If only one or two of these range monitoring options are used, the limits of the unused ranges must be set to their limit values (e.g., **C43=0%** and **C44=400%** when torque monitoring is not required).

9. Special functions

9.4 Parameter record selection

The FDS inverter supports two separate parameter records. Specification of the active parameter record is performed in one of the following ways.

- Externally via a binary input (**A41**=0)
- Internally via a keyboard (**A41**=1 or 2)

The active parameter record is indicated in **E84**. To specify via a binary input, one of the parameters **F31** to **F35** must be set to "11:paraSet-select" in both parameter records. Selection never takes place unless the power section is deactivated.

The parameters of both parameter records can be indicated and programmed regardless of which parameter record is currently active. **A11** (paraSet Edit) is used to specify the parameter record (1 or 2) to be edited. When parameters of the 2nd record are involved (**A11**=2), a **□** is indicated to the right of the parameter number.

Certain parameters (e.g., operation input, **A30**) are only available once, and a **□** is then not indicated next to the parameter number. This applies to all parameters of group **A**, the display parameters of group **E** (e.g., torque, utilization and similar), and positioning (groups **I**, **J**, and **L**).

Example of time behavior with quick stop for enable-off (**F38**=1. For release, see also **F31**=11).

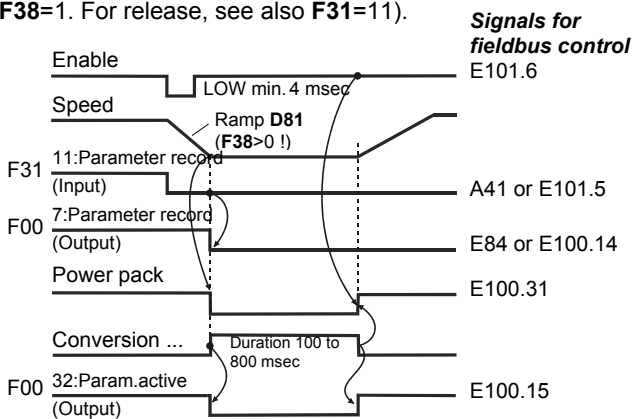

When autostart is active (**A34**=1), the switchover takes place immediately when the edge of the signal "11:Paraset" occurs. Enabling is automatically deactivated internally.

Parameter records can be copied via **A42** and **A43** (copy paraSet). **A42**: copy paraSet 1 > 2 to "1:active" overwrites parameter record 2 with the values of parameter record 1.

⇒ Usually, the first parameter record should be set up first.

The parameters are copied to parameter record 2 with **A42**=1 (active). **A11**=2 is then used to switch to parameter record 2 and edit the necessary values there. After completion, all parameters are saved with **A00**=1.

Remember: When the mode (**C60**) is switched from position to speed, the actual position during **C60**=1 is only partially calculated. This means the reference position is lost when you switch back (**I86**→0). Exception: SLVC with **C60**=1, VC with **C60**=2.

With electronic drives, the internal variables like the current angle of deviation are retained when a parameter record is switched (prerequisite: **C60** remains the same). However, the parameters of group **G..** are switched.

9.5 Motor potentiometer

The "motorpoti function" can be used to steplessly increase or decrease the motor speed via two binary inputs:

- Two binary inputs are programmed to "4: motorpoti up" or "5: motorpoti dwn" via **F31** to **F35**.
- The "motorpoti function" is activated with **D90**=1.
- When the key is pressed, the speed is changed in accordance with ramps in **D00** and **D01**. When the "motorpoti function" is active (**D90**=1), most of the parameters of group **D** (reference values) are not indicated.
- The maximum speed corresponds to the value set in **C01**.
- **D90**=2 causes the motor potentiometer to be added to the normal reference value.
- The reference value generated by the motor potentiometer is set to **C00** (n-Min) if both binary inputs are high.
- With **D91**=0, the reference value which was approached last is stored non-volatily.
- With **D91**=1, the motor potentiometer reference value is reset with enable-off.

9.6 Speed feedback

Standard FDS inverters support speed feedback via an incremental encoder (24 V). Control mode **B20**=2 (vector control with 2-track feedback) provides precise and highly dynamic control of speed and torque (i.e., asynchronous servo drive). To commission speed feedback, proceed as shown below.

■ Wiring (without option board)

Incremental encoder tracks A and B are connected to binary inputs BE4 and BE5. The power supply for the encoder (+24 V) must be provided externally. The encoder can be connected to the inverter directly (recommended) or with conventional terminal blocks.

Encoder Pin	Color of STÖBER Cable	Encoder Signal	Binary input	Connection
1	Yellow	/B		
3	Pink	C	Input BE3*	X 1.12
4	Gray	/C		
5	Brown	A	Input BE4	X 1.13
6	White	/A		
8	Green	B	Input BE5	X 1.14
9	--	Shield		Shield terminal
10	Blue	0 V	External 0 V	X 1.8
12	Red	+V _B	External 24 V	---

* Only evaluated by POSI software if **I31**=1.

9. Special functions

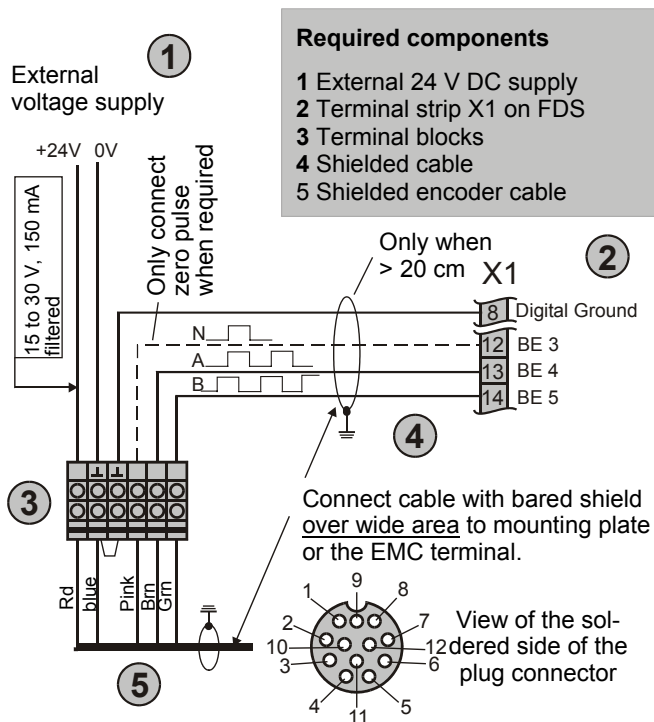

Required components

- 1 External 24 V DC supply
- 2 Terminal strip X1 on FDS
- 3 Terminal blocks
- 4 Shielded cable
- 5 Shielded encoder cable

- With regard to EMC requirements, it is better to connect tracks A, B and C directly and not with terminal blocks.
- **F34=14** and **F35=15** are used to program binary inputs BE4 and BE5 for speed feedback. Activate extended menu with **A10=1** before.
- If necessary, **F36** can be used to change the increment number of the encoder (default setting: 1024 ppr).
- If necessary, connect encoder zero pulse to BE3 (**F33=14**) for positioning (**C60=2**).

■ Connecting the encoder to option board GB-4001 or EA-4001

- For wiring on plug connector X20, see chapter 14.1. Pay particular attention to parameters **B26=1** (motor encoder = X20) and **H22** (X20 increments).

■ External encoder behind the gearbox

- The motor can also always be controlled with an encoder directly on the machine.
- The number of increments converted to the motor shaft must be entered in **F36** or **H22**. (*SSI4000*: see chap. 10.11.1.)
- **F49** (BE-gear i) and **H23** (X20) can only be used for positioning control (see chap. 10.11.2).

⚠ Caution: A connection between motor and external encoder in which there is vibration, play or slip may cause problems with control. The resolution converted to the motor shaft should be at least 500 increments.

Checking the wiring

- In control mode *U/f control* or *Sensorless Vector* (**B20=0** or 1), let motor rotate, and make a note of the speed (with sign). Look at the actual speed in parameter **E15** (n-Encoder). The speed should be similar to that shown in the status indication. In particular, the sign must be the same.

Possible problems

Sign is wrong: Check motor connection (sequence of the phases), and reverse signals A and B of the encoder, if necessary.

0 rpms indicated in E15: Is $V_B=24$ V applied to the encoder with the correct polarity? Is the grounding connection okay? Are there any other wiring errors? Are **F34** and **F35** programmed correctly? Is **B26=0** for BE4/5 encoder or **B26=1** for encoder on X20? Signals A and B can be checked separately. Stop the motor, and look at parameter **E13**. Even the slightest motor rotation (e.g., by turning the fan wheel manually) must cause the level of BE4 and BE5 to change.

Activating vector control

- Stop motor, and select control mode **B20=2** (vector control).
- Let motor rotate. If problems occur, check the above items again.
- Save parameters with **A00=1**.
- ⇒ If the sign of speed feedback is wrong, the motor rotates slowly and does not react to reference values. Or the fault "33:overcurrent" is reported.
- The dynamics of the speed control circuit are primarily dependent on parameters **C31** (n-controller K_p) and **C32** (n-controller K_i). They determine proportional and integral gain of speed control. Excessive gain causes the motor to vibrate, while insufficient gain reduces dynamics. The default setting can usually be retained. If necessary, adjust **C31** first. **C32** affects the "load capability." When large external masses or overswings are involved, **C32** may have to be reduced during positioning (2 to 30%).

9.7 Acknowledgment of faults

The table of possible faults is located chap. 17. Faults are acknowledged in the following ways.

- **Enable:** Change from L to H level on the enable input, and then back to L. Always available.
- **Esc** key (only when **A31=1**)
- **Auto reset** (only when **A32=1**) } **⚠ Caution!** Drive starts up immediately.
- **Binary input** (**F31** to **F35=13**)

Parameters **E40** and **E41** can be used to scan the last 10 faults. Value 1 represents the last fault. FDS Tool can be used to assign as desired the inverter reaction (e.g., fault, warning, message or nothing) to certain events. Cf. chap. 17.

9.8 Motor startup



- The auto-start function can be used to permit the drive to start up immediately after the power is turned on (cf. chap. 16).
- **Before the auto-start A34=1 is activated, it must be ensured that the automatic startup cannot cause hazardous system states!**
- **C20=1** (load start), **C21** and **C22** can be used to specify an overload to be tolerated when sluggish machines start up (*V/f control*).
- **C20=2** (cycle characteristic) is used to obtain optimum acceleration with *Sensorless Vector Control* (**B20=1**). For more information, see also parameter **C30** and chapter 9.2.

9.9 Control via PC

The **FDS Tool** software can be used to control the frequency inverter with a PC. The inverter is connected to the PC with sub D plug connector X3 (RS 232-C interface) and FDS cable G3 (cat. no. 41488). With its integrated **FDS Scope** feature (oscilloscope function), FDS Tool permits eight different measured variables to be recorded at the same time to optimize the drive.

10. Positioning Control

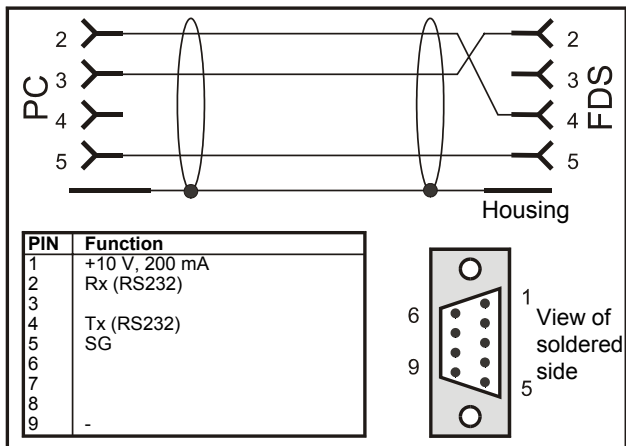

FDS cable G3, cat. no. 41488

Connection cable between the serial interface of the PC (Notebook) and serial interface X3 of the FDS. Only applies to FDSs with a sealed keyboard. Do NOT replace with a conventional serial connection cable. Such cables can only be used with a special adapter (cat. no. 41489).

The +10 V on pin 1 is exclusively to power a Kommubox and/or a Controlbox.

Caution: A brief short circuit against ground can cause a brief reset of the processor.

The RS232 interface can be used to create a low-cost network of several inverters with an „RS232 ring“:

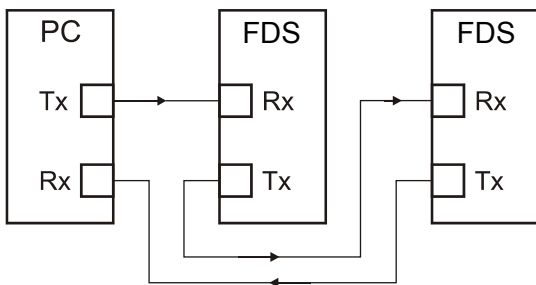

Networking with an RS232 ring is supported by FDS Tool.

The RS232 ring can be used to control the inverters by communication via USS protocol.

For more information on the USS protocol, see the USS documentation (no. 441564).

10 POSITIONING CONTROL

The basic model of the FDS 4000 frequency inverter offers integrated positioning control. A motor with a built-on incremental encoder or SSI encoder is the prerequisite for precise and reproducible positioning. In "Vector Control" mode (B20=2), the motor provides the characteristics of an asynchronous servo drive. Positioning can also be used without encoders in control mode SLVC (Sensorless Vector Control).

10.1 Function overview

- 8 positions can be programmed as 8 process blocks.
- Destination travel is precise to the increment.
- Continuous position control with following error monitoring
- Parameterization in units (e.g., degrees and mm)
- Resumption of interrupted process blocks possible
- Change in destination possible during traversing
- Reference point travel with several modes
- Sequence programming possible via process block chaining (e.g., "Go to pos. 1, wait 2 sec, go on to pos. 2, wait for signal and return")
- Tip mode (inching)
- Teach-in function
- Speed override via analog input possible
- Any gear ratios are precisely calculated with fractions. No drifting with continuous axes.
- Continuous referencing for continuous axes
- "Electrical cam" function switches digital output within programmed position range.
- Hardware and software limit switch
- Rotary attachment function
- Path specification via analog input possible
- Brake control for lifting systems
- SSI absolute value encoder (also continuous operation)

10.2 Connections

The standard device without option board is used for simple applications.

Applications with greater demands on binary inputs require the use of the **EA 4001 option board**. The EA 4001 expansion offers a convenient encoder connection, 24 V external voltage supply, 5 binary inputs and 3 binary outputs.

An analog input or fieldbus can be used to adjust positioning speed steplessly. Called "speed override," this function is not only useful during commissioning but also for tipping mode, changes in the number of pulses of a machine, and so on.

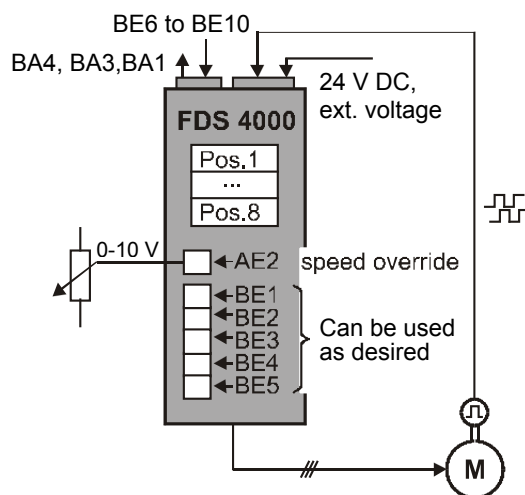

10. Positioning Control

The following functions for **binary inputs** (parameters **F31** to **F35** and **F60** to **F64**) are important:

- **RV-select0 to 2:** Binary coded position selection. Process block 1 is selected with "000," and process block 8 is selected with "111."
 - **8:halt:** Rising edge interrupts running motion with the current process block ramp. Since tip mode (i.e., inching) via binary inputs is not possible unless *halt* is active, *halt* switches between *tip* and *automatic operation*.
 - **9:quick stop:** Rising edge interrupts positioning with maximum acceleration **I11**.
 - **16:posi.step:** When a chain of process blocks is being used, *posi.step* starts the consecutive process blocks. A movement which is in progress is not interrupted (→ **I40**).
 - **19:posi.start:** Starts the just selected process block. A movement which is in progress is always interrupted.
 - **20:posi.next:** Only for chained process blocks. If programmed appropriately (cf. **J17=3**), immediately concludes the running process block, and starts the next one. A remaining path which is to be traveled after *posi.next* occurs can be defined. See chapter 10.8.
 - **17:tip+, 18:tip-:** Tip mode (i.e., inching)
 - **21:stop+, 22:stop-:** Limit switch
 - **23:reference input:** Reference switch connection
 - **24:start reference:** Starts reference point traversing
 - **25:teach-in:** Actual position is assumed in the just selected process block.
- ⇒ The binary inputs can be inverted via **F51** to **F55** and **F70** to **F74**. (→ wire-break-proof connection).
Removal of the **enable** always causes a quick stop with maximum acceleration **I11**.

Analog inputs AE2 and AE1 (par. **F20** and **F25**)

- **1:additional RV:** Relative traversing paths are multiplied by (100% + level). Example: 0 V → no offset (i.e., 100% of the traversing path).
- **4:RV-factor:** Relative traversing paths are multiplied by level. Example: 0 V → no motion (i.e., 0% of the traversing path)
- **5:override:** The programmed positioning speed can be changed online via potentiometer ("speed override" function for CNC controllers), for example.
- **6:posi. offset:** An offset can be added to the current position online via AE2. Cf. parameter **I70**.

Binary outputs (par. **F00**, **F80**, **F81**, ...)

- **3:Ref Val reached:** Location in position window **I22**. Signal appears when drive "in position."
- **8:electrical cam:** Signal appears when the actual position is located between parameters **I60** and **I61**. Signal is used as message to other modules, for example.
- **9:Following error:** Signal appears when the maximum following error in **I21** is exceeded.
- **10:Position active:** Drive is in position control waiting for *posi.start* or *posi.step*. No process block and no process block chain being processed.
- **13:referenced:** Drive is referenced.
- **19:s-memory1 to 21:s-memory3:** Output the memory locations which are set by the posi-switching points during process-block movements (chap. 10.12).
- **23:RV-ackn.0 to 25:RV-ackn.2:** Binary coded response message of the active **I82** process block. Cf. diagram in chap. 10.3.

⇒ A **fieldbus** also offers a simple and easy way to access these signals. *Status* and *control bits* (**E100** and **E101**) are just two examples. For details, see documentation of the fieldbus.

10.3 Destination positioning / process blocks

Each position to be traveled to is described by several parameters. Together these parameters make up a **process block**. Eight process blocks are available. This permits 8 different positions to be approached. Process block no. 1 is described by parameters **J10** to **J18**, while the second process block is described by parameters **J20** to **J28**, and so on.

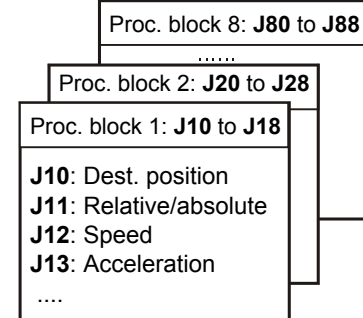

A process block can be **selected** in the following ways.

- **J02=1...8.** The entered value corresponds to the particular process block.
Entry of the value "0" permits selection of the process block via "reference value-select" entry.
- Via "reference value-select" inputs;
With **J02=0** the process block can be selected via the inputs "Ref. Value select 0" to "Ref. Val. select 2". The binary combination "000" selects process block no. 1; "111" selects process block no. 8.

The **response** of the current process block occurs as shown below.

- In parameter **I82** ("active process block")
- In the 2nd line of the operational display
- Binary coded via binary outputs "23:RV-ackn.0" to "25:RV-ackn.2". The selected process block is shown inverted until the movement begins.
When a process block is started, the active block is not output inverted (binary coded like the *RV-select* signals) as long as *posi.start*, *posi.step* or *posi.next* is queued.
If a process block cannot be started (e.g., see "51:refused", chap. 17 Faults/Events), the selected block continues to be output inverted. This also happens when a movement is terminated.

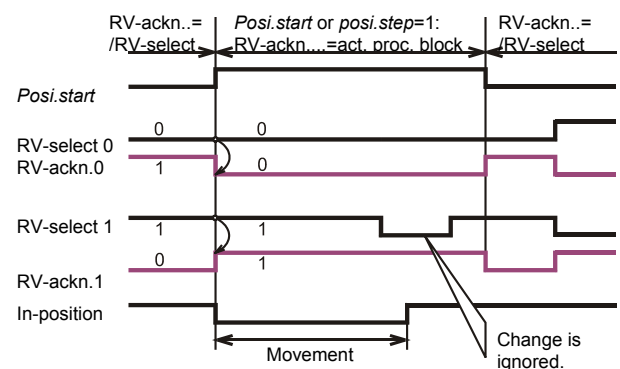

⇒ When the position is specified directly by **fieldbus**, process block 1 (**J10**) receives special treatment. The inverter does not acknowledge the write access until all internal conversions are complete and the inverter is "ready to start." Parameter **E124** ("start.pos 1") is also available via the fieldbus. **J10** is written here and then started automatically after conversion is complete. Output signal "32:parameters active" indicates the end of a parameter conversion.

10. Positioning Control

10.4 Absolute / relative positioning

One of 4 possible traversing methods (parameters **J11**, **J21**, **J31** and so on) can be assigned to each process block.

- Relative
- Absolute
- Continuous, positive
- Continuous, negative

A **relative** path always refers to the current location (chain dimensions).

An **absolute** position refers to a fixed reference point (i.e., machine zero point) which is determined with *reference traversing*. See chapter 10.6. For this reason, an absolute position always requires reference traversing. Any start commands given without reference traversing are answered by the inverter with "51:refused".

When a process block is defined as **continuous** and a start command is given, the axis continues to move in the specified direction until a signal arrives from the outside (e.g., *posi.next* or *posi.start*). The speed can be adjusted via an analog input (e.g., set the AE2 function **F20=5:Override** for this.)

Successful conclusion of a movement is signaled via the output signal **reference value-reached** (**F00=3** and **F80=3**). This signal appears when the actual position lands in the **position window** (destination ± 122) for the first time. The signal is not withdrawn until the next traversing command is given.

10.5 Commissioning

This section only covers the drive with encoder feedback (**B20=2**).

Important: Before positioning control is activated, speed control must be commissioned (chapter 9.6) and, if necessary, optimized with FDS Scope. Positioning control is activated with

C60=2:Position

The **status indicator** changes and displays the actual position in the first line.

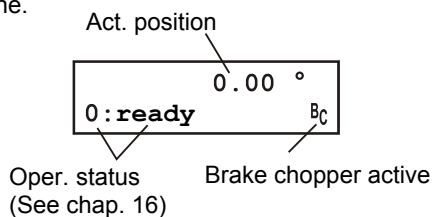

If **B20≠2**, the first line continues to show speed and current. While process blocks are being processed, the lower line also indicates the number of the active process block.

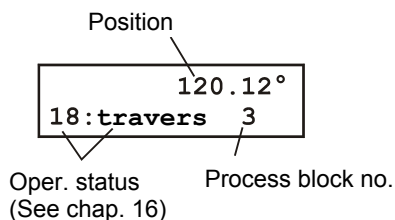

Important: If you want to change the location of the decimal point in the position display via **I06** (**I06=decimal point shift**), do this at the beginning of commissioning since the significance of all positions is changed.

10.5.1 Limited traversing range

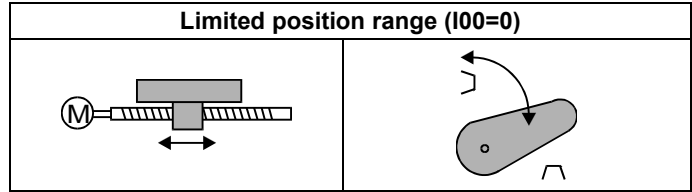

Limited traversing range means that the permissible area of movement is restricted by end stops or similar. Safety requires that **limit switches** be provided. If the inverter is not equipped with a sufficient number of free inputs (i.e., operation without an option board), the limit switches must be evaluated by a higher level controller. The primary parameters are listed below:

- **I00=0** Limited traversing range
- **I05:** Unit of measurement (e.g., mm, degree (°) and inch, user)
- **I06:** Number of decimal places
- **I07:** Distance per encoder revolution (e.g., mm/U)
- **I10:** Maximum speed (e.g., mm/sec)
- **I11:** Maximum acceleration (e.g., mm/sec²)
- **I12:** Tip mode speed

Important: Since some parameters in groups **I** and **J** (e.g., paths or accelerations) may assume very large values, the keys can be used to directly select the tens exponent to be changed. Only the individual digit flashes and not the entire number. The keys can be used to increment/decrement the value by the selected tens exponent:

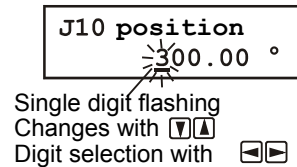

⇒ Before starting testing, check the limit switches, and decouple the drive from the machine if necessary.

The enable can now be activated as the first test. The display indicates

17: posi.active .

The position control loop functions, and the current position is maintained. During the next step, the drive is moved via **tip mode** (i.e., **inching mode**). Set parameter **J03=1** for this. The keys can be used to traverse the drive.

⇒ The speed can also be changed during traversing via analog input AE2 (**F20=5**).

The next step is the commissioning of reference traversing. See chap. 10.6. **Software limit switches I50** and **I51** can be programmed with a reference axis (**I86=1**). The software limit switches prevent movement to positions outside **I50** and **I51**.

A short relative movement (**J11=0**) can be specified for testing purposes in **J10** (destination position process block 1). The speed is entered in **J12**, while the ramps are entered in **J13** and **J14**. **J00=1** can be used to start and monitor the movement. Do not forget the enable.

10. Positioning Control

10.5.2 Continuous traversing range (rotary axis)

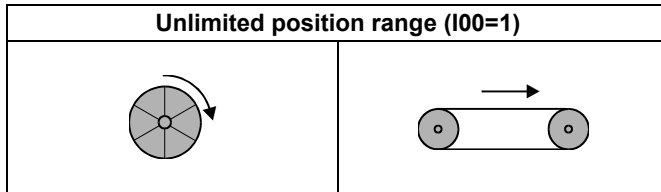

The most important feature of a continuous traversing area is the cyclic repetition of certain positions for movement in one direction (e.g., hand on a clock).

Rotary axis function: Selecting **I00=1:unlimited** means that the actual position is only counted up to *circular length I01* (e.g., 360°). After reaching this value, you start over again with zero. When both directions are permitted (**I04=0** and **I03=1**), the shortest path is taken for movement from point A to point B (absolute target specification) → **direction optimization**.

Gear ratio: Parameters **I07** and **I08** can be used to specify the exact gear ratio (using the tooth numbers). This prevents drifting away with relative positioning. Cf. examples in chap. 10.9.

Direction of rotation: When both directions are permitted (**I04=0**), the shortest path (**I03=1, direction optimization active**) is taken for movement from A to B with absolute target specification. However, when the process block is changed on the fly, the original direction of rotation is retained. Restriction of the permissible direction of rotation (**I04**) affects all process blocks and manual traversing. Another method is to deactivate direction optimization with **I03=0**. To then be able to traverse an absolute destination in the *negative* direction of rotation, you must enter the destination with a *negative sign* while taking the modulo calculation into consideration. Example: After -270° is entered, the drive rotates *counterclockwise* to position 90°.

10.6 Reference point traversing

When the position is measured with an *incremental encoder*, the actual position is not known when the power is turned on (power supply or external 24 V). A defined starting position is achieved with reference point traversing. When an *absolute value encoder* is used, only *one* drive referencing procedure is required for commissioning and when an inverter is replaced. Absolute movements can only be performed in referenced status. The referenced state is signaled with **I86=1** and can be output on the binary output.

Reference point traversing is parameterized with **I30** to **I38**. The primary parameters are listed below.

- **I30:** Type of reference point traversing
- **I31:** Direction of reference point traversing
- **I32:** High-speed reference point traversing
- **I33:** Low-speed reference point traversing
- **I35:** Zero-pulse incremental encoder - evaluation
- **I37:** Automatic reference point traversing at power-on

There are three ways to start reference point traversing.

- Automatically (**I37=1** or **2**)
- Signal on binary input (**F31 ...=24**)
- Inching with **J05=1**

Reference mode **I30** specifies the required initiators or the functions for binary inputs. **I30=3:def.home** is frequently used to set the machine zero point when *absolute value encoders*

are used. **I31** is used to determine the (search) direction when reference point traversing is started. If the reference switch (or limit switch) is active, the direction is reversed. Cf. example 2 on the next page. The correct value for **I31** can be tested by inching the axis (parameter **J03**), for example. The status of the binary inputs can be scanned in **E12**, **E13** and **E19**.

When only one direction of rotation (**I04**) is permitted, the drive traverses up to the *rising* edge of the reference switch in direction **I04** at speed **I33**. Referencing direction **I31** is ignored in this case.

The zero pulses of the incremental encoder are only evaluated when **I35=1**. With inverters without option boards, the zero track is connected to BE3.

Usually the zero track cannot be used with continuous axes unless the mechanics have an even-number ratio.

Specification of two speeds (i.e., **I32** and **I33**) is primarily an advantage for long linear axes.

The **acceleration** during reference point traversing is ½ of the maximum acceleration in **I11**. When the reference point is detected, the actual position is set to **I34** (i.e., reference position), and the drive brakes until it is at a standstill. The distance required for reversal or braking is generally

$$\text{Distance} = \frac{1 v^2}{2a}$$

with V: speed
a: Acceleration (**I11/2** here).

After reference point traversing has been concluded, the drive remains where it is after the required braking distance (**I33²/I11**) and does not return to the reference position. Cf. above. The AE2 "override" function (**F20=5**) changes the speed and also the braking distance.

10. Positioning Control

Example 1: I30=0:ref.input, I31=0:positive

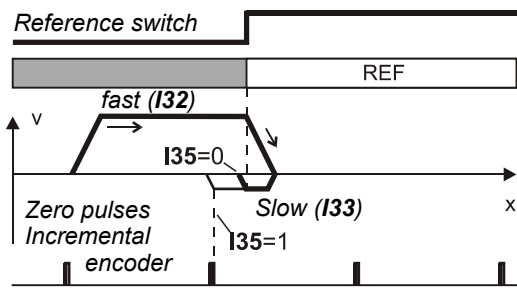

Since the reference switch divides the total traversing area into two halves, no other switches are required.

Example 2: I30=0:ref.input, I31=0:positive

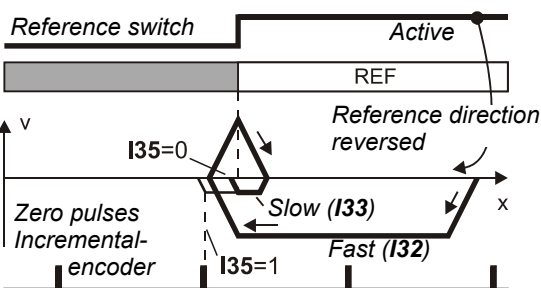

The direction defined in I31 is reversed if the reference switch is active at the beginning.

Example 3: I30=0:ref.input, I31=0:positive

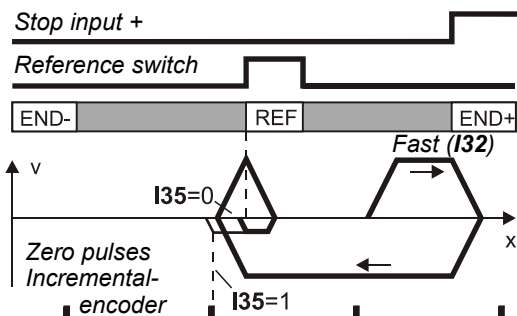

The reference switch (i.e., cam) only reacts briefly. A limit switch is used for the reversal..

Example 4: I30=1:limit input, I31=0:positive

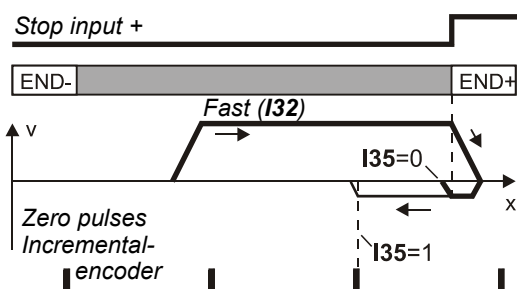

A limit switch can be used for referencing instead of a reference switch.

When the power or the external 24 V voltage supply fails, the information on the reference position is lost. After power returns, I37=1 is used to automatically trigger reference point traversing with the first start command (i.e., *posi.start* or *posi.step*).

After a reference point traversing procedure has been concluded, you can automatically move to any initial position by programming parameter I38 (*ref. block*) to the number of the parameter record to be moved to.

10.7 Position controller

To minimize following error deviation (i.e., difference between reference value and actual position), the FDS uses speed precontrol. The maximum permissible following error deviation specified in I21 is continuously monitored. The position controller is running continuously during the entire movement.

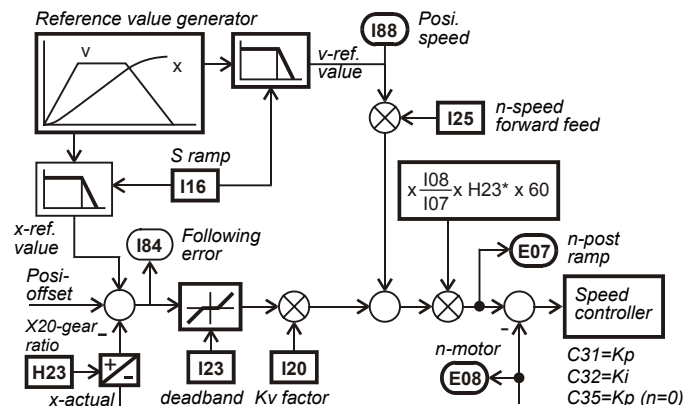

* H23 (X20 gear ratio factor): Example of position control via X20

The gain of position control I20 (i.e., the "stiffness" of control) is called the "Kv factor."

Parameter I16 (S-ramp) can be used to parameterize reverse-limited traversing profiles and prevent high-frequency excitation by a low pass. Time constant I16 corresponds to a low-pass limit frequency of $fg=2\pi/I16$.

10.8 Process block chaining

Next block parameters J16, J26, J36 and so on can be used to chain process blocks into sequences. For example, at the end of one process block, this can be used to automatically move to an additional position (i.e., next block). The following parameters apply to the 1st process block.

- J16 next block. If J16=0, then no chaining.
- J17 next start. Specifies how next block J16 is to be started.
- J18 delay. Applies when J17=1:with delay

For details on J17, see the parameter table.

Example 1: With a rotary attachment, 60° steps are performed in a continuous cycle with 1-sec pauses in between.

Solution: J10=60° (Path)
 J11=0:relative (Position mode)
 J16=1 (Next block no. 1)
 J17=1:with delay (Next start with delay)
 J18=1.000 sec (delay of 1 sec)

⇒ Process block no. 1 starts itself.

10. Positioning Control

Example 2: Three fixed positions are always traversed in the same order (*pick and place*).

Solution: **J10, J20, J30**=Destination specification
J11=J21=J31=1:absolute
J16=2, J26=3, J36=1 (chaining)
J17=J27=J37=0:posi.step

⇒ The movements are triggered by the rising edge of the *posi.step* signal.

Example 3: A conveyor belt is to stop after exactly 100 mm following a sensor signal.

Solution: **J11=2:endless positive**
J16=2 (Next block no. 2)
J17=3:posi.next (Next start)
J20=100 mm
J21=0:relative

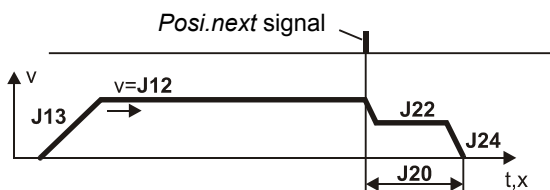

⇒ The *posi.start* signal starts process block no. 1. The drive continues to run until the rising edge of the *posi.next* signal after which a branch is made to process block no. 2. When *posi.next* is connected to BE3, the reaction occurs without a delay time. If the **J17=3:posi.next** setting is not made, *posi.next* is ignored! Cf. example 4.

Example 4: Positioning of a shelf handling device. The exact destination position is specified by a light barrier which is triggered briefly at each shelf. Until just before the destination, the signals of the light barrier must be ignored. We will assume that the destination is located between 5.1 m and 5.4 m.

Solution:
 The approximate position is traveled to with block no. 1:
J10=5.1m (Approximate position)
J11=1:absolute
J16=2 (Next block no. 2)
J17=2:no stop (Next start)

Posi.next is activated with block 2 (**J27**):
J20=5.4 m (Maximum position)
J21=1:absolute
J26=3 (Next block no. 3)
J27=3:posi.next (Next start)

The braking distance is defined in block 3:
J30=0.05 m (Braking distance)
J31=0:relative

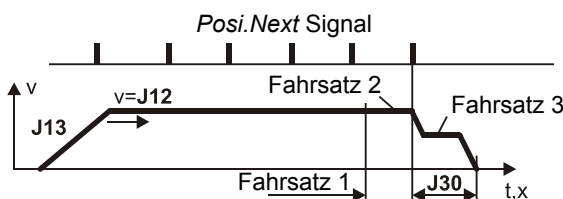

⇒ Process block no. 1 is started with *posi.start*. Just before the probable destination and without an intermediate stop, a switch is made to process block no. 2 where the *posi.next* signal is armed. Process block no. 3 is triggered with *posi.next*, and the braking distance specified in **J30** is executed. If the *posi.next* signal fails to appear (e.g., light barrier is defective), the drive remains stopped in position **J20**.

Tips:

- An operational status of *17:posi.active* indicated on the display means that no process block and no chain of process blocks (i.e., sequential program) is being executed at the moment. The drive is under position control. The *posi.start* and *posi.step* signals have the same effect here.
- The inverter assumes the basic state "*17:posi.active*" when the enable is turned off and on.
- The "*17:posi.active*" state can also be output on binary outputs or relay 2.

10.9 Simple examples

Without the option board, 5 digital inputs are available. Of these, BE4 and BE5 are required for the connection of the encoder. Some examples of how the remaining three inputs can be used are listed below:

Example 1: Belt drive (i.e., endless movement). Four different feed lengths are traversed relatively.

Solution: BE1: RV-select0 (**F31=1**)
 BE2: RV-select1 (**F32=2**)
 BE3: *posi.start* (**F33=19**)

BE1	BE2	Block	Process Block Parameter
0	0	1	J10, J12, J13, J14
1	0	2	J20, J22, J23, J24
0	1	3	J30, J32, J33, J34
1	1	4	J40, J42, J43, J44

⇒ The traversing method (e.g., **J11, J21, J31** and so on) remains set to "*0:relative*" for all blocks. The selected process block is indicated in **I83**.

Example 2: Linear axis with end stops. Two fixed positions are traversed absolutely.

Solution: BE1: RV-select0 (**F31=1**)
 BE2: *posi.start* (**F32=19**)
 BE3: ref.input (**F33=23**)

BE1	Position	Process Block Parameter
0	1	J10, J12, J13, J14
1	2	J20, J22, J23, J24

⇒ The traversing method (**J11** and **J21**) for both process blocks is "*1:absolute*." After power-on, reference point traversing is automatically executed by **I37=1** with the first *posi.start* command. The reference switch must have the characteristics shown in example 1 of chapter 10.6.

Example 3: Belt drive (endless movement) with stop at pulse (i.e., defined braking distance).

Solution: BE1: *posi.start* (**F31=19**)
 BE3: *posi.next* (**F33=20**)
J11=2:endless positive
J17=3:posi.next
J20=...(braking distance)

⇒ We recommend applying the *posi.next* signal to BE3 (**F33=20**) so that the delay time of 4 msec is omitted. Evaluation of *posi.next* is activated with **J17=3**.

For additional details on *posi.next*, see chapter 10.8 (chaining of process blocks).

10. Positioning Control

Example 4: A rotary attachment is to be positioned continuously and without drift in 60° increments. A STÖBER K302 0170 with $i=16.939393\dots$ is to be used as the gearbox. The exact ratio is $i=3354/198$.

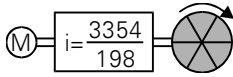

Solution: The rotary attachment rotates precisely $360^\circ \times 198 \div 3354$ per encoder revolution. Thus, $I07=71280$, and $I08=3354$. The path is programmed in degrees ($J10=60^\circ$). The circular length $I01$ is 360° .

Example 5: A toothed belt drive is to move continuously and without drift in fixed increments (41 catches per circular length). The toothed disk has 23 teeth, while the belt has 917 teeth. For gearbox, see above. o.

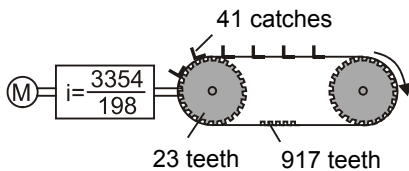

Solution: To obtain a precise solution, $1/41$ of the circular length is taken as the unit of distance ($I05=0$). One unit of distance corresponds to the feed by exactly one catch. The belt drive rotates precisely $198 \div 3354 \times 23 \times 41 \div 917$ units of distance per encoder revolution. Thus, $I07=186714$, and $I08=3075618$. The path is programmed in units of distance= $1/41$ of the circular length. The circular length $I01$ is 41 units.

Example 6: A conveyor belt drive with slip is to move in fixed increments continuously and without drift. Exactly 41 catches are distributed over a circular length of 4 m.

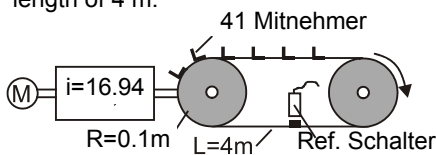

Solution: The distance per encoder revolution is $2\pi R/i$. Thus $I07=37.09$ mm/U. Drift is prevented by continuous referencing ($I36=1$) or the *posi.next* signal.



Important: The distance to be traveled (e.g., $J10$) multiplied by the number of catches (41) must precisely equal the circular length $I01$. If not, the drive will drift away even with continuous referencing. If necessary, $I01$ and $I07$ must be adjusted accordingly. The reference switch should be located between two catches.

Important: When continuous referencing $I36=1$ is used, $I07$ must always be rounded off to the next higher number.

Example 7: Screw/press controller
Starting at a certain position, the torque is to be monitored. When a limit is exceeded, a return to the start position is made.

Solution: The first part of the movement is handled by process block no. 1. Without stopping, the system switches in time to process block no. 2 before the end position ($J16=2$ and $J17=2$). The speed remains the same ($J12=J22$). When the torque limit (working area) specified by $C44$ is exceeded, the system switches to process block no. 3 ($J26=3$ and $J27=4$). In our example, the working area is limited by the maximum torque $C44$. See following diagram.

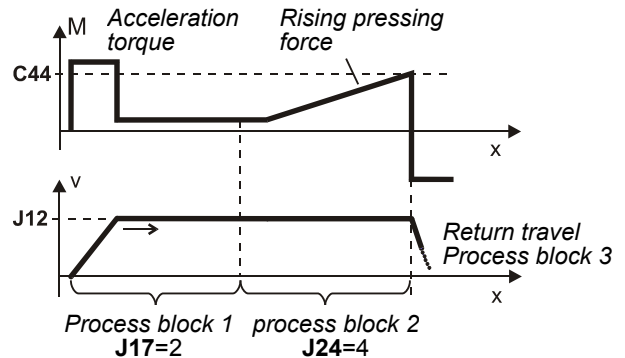

10.10 Emergency off

If the power is cut off from the inverter with the emergency off switch, all information on the position is lost. When the inverter goes on again, the power must be referenced again.

A movement that has been interrupted by an emergency off can be continued and completed with a 24 V power supply from an option board under the following conditions.

- The HALT signal becomes active at least 4 msec before the enable is removed.
- The HALT signal remains present until power returns and the enable is active.

Another method of interrupting and continuing a process block is to use the sequence of signals shown below.

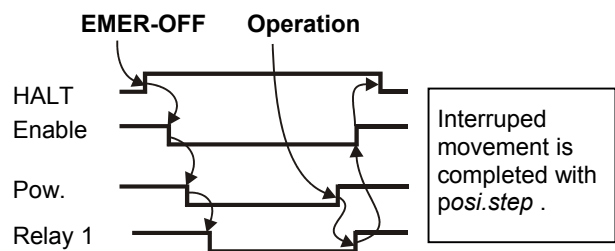

Parameter $I19=1$ can be used to specify that an enable-off will lead to "23:interrupted." The interrupted process block can then be completed with *posi.step*. With the default setting ($I19=0$), removal of the enable causes sequence control to be reset (status "17:posi.active"). Process blocks with chaining „without stop“ ($J17=2$) can only be terminated (status „17:posi.active“).

10. Positioning Control

10.11 Extern. rotary/linear path measurement

There are two ways to perform positioning with an "external" measuring system mounted directly on the machine.

1. Positioning is performed with the external measuring system. The motor is controlled by its own encoder (standard case).

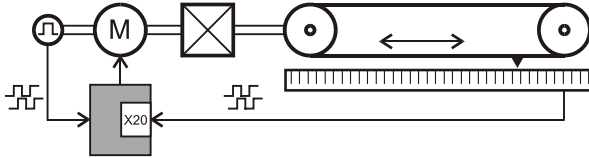

Important: When the motor is controlled with its own encoder, the external measuring system must supply at least 30 measuring increments/rotation (converted to the motor shaft).

2. The external measuring system handles both position and motor control. The measuring system is parameterized as motor encoder (→ B26). Conversion to the motor shaft is handled by the "gear factor" (e.g., H23 for encoder on X20).

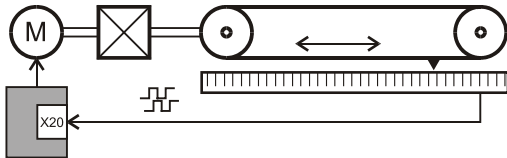

Important: A connection between motor and encoder which is subject to vibration, play or slip usually creates practically insurmountable problems. The resolution (converted to motor shaft) must have at least 500 increments (optimum > 1000).

10.11.1 Encoder

The encoder for position control is selected with I02 while the encoder for motor control is selected with B26. The following table lists the possible interfaces with supply voltages (U_B) and parameters for the number of increments (Inc/R), and the gearbox factors between motor and encoder (gear i).

	Remarks	U _B	Inc/R	Gear-i
X20	TTL + HTL incremental encoder*, SSI encoder*	18 V	H22	H23
BE	HTL incremental encoder	-	F36	F49

* With option boards (chap. 14)

10.11.2 Adjustment of motor/ext. measuring system

The movement of the external measuring system must be adjusted to the motor shaft. First, the increments of the encoder and its gear factor must be parameterized. This is done in two steps as shown by the example of an external encoder on X20 (set H20=2:encoder in - chap. 14).

- 1) Determine number of **measuring increments per motor revolution** (1 measuring increment = 1 scaling increment on the measuring scale or one increment of a rotary encoder). **Example:** One measuring increment of 0.07 mm and a spindle incline of 20 mm/revolution results in 20/0.07 = 285.71 measuring incr. per motor revolution.

- 2a) **Incremental measuring systems:** The number of increments per motor revolution is rounded to a whole number ("round" function in the formula below) and parameterized as H22¹ encoder increments (example for input X20).

H22=Round (measuring increments per motor revolution)

The rounding error is offset by the "gear factor" of the encoder (H23 gear i).

$$H23 = \frac{H22}{\text{Meas. incr. per motor rev.}}$$

- 2b) **SSI measuring systems:** Here, two different cases must be distinguished between.

a) Measuring increments per revolution > 128*N

b) Measuring increments per revolution ≤ 128*N

With N=1 for 24-bit encoders and N=2 for 25-bit encoders

Case (a): Only H23 (gear i) must be adjusted.

$$H23 = \frac{N \times 4096}{\text{Meas. incr. per motor rev.}}$$

Case (b): H22¹ (X20 increments) must also be adjusted.

H22=Round (measuring increments per motor revolution / (4*N))

$$H23 = \frac{4 \times N \times H22}{\text{Meas. incr. per motor rev.}}$$

Example: With a 24-bit SSI measuring system, 43.6 measuring increments per motor revolution result in Round (43.6/4)=11¹. Therefore, H22=30 and H23 = (4*30/43.6) = 2.752 must be set.

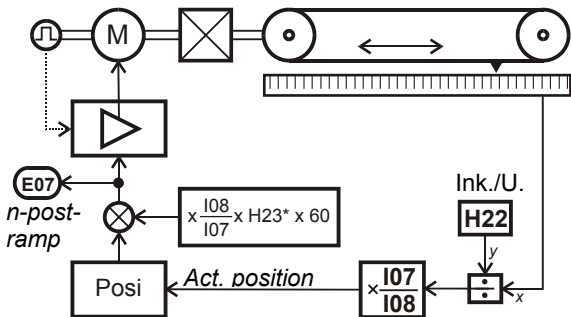

10.11.3 External encoder and posi parameters

The encoder for position control is selected with I02. I07 / I08 mathematically specifies the path per encoder revolution (one encoder revolution = rounded number of increments in H22 as shown in chap. 10.11.2). Example of linear measuring system: A measuring increment of 0.07 mm and a spindle incline of 20 mm/revolution results in H22 = Round (20/0.07) = 286. Thus, one "encoder revolution" is 286 * 0.07 = 20.02 mm. I07=20.02 mm and I08=1R apply accordingly.

To prevent control vibrations caused by mechanical friction or play, deadband I23 can be used to deactivate position control within a narrow area.

¹ If the H22 calculation < 30, set H22=30. The difference is offset when H23 is calculated.

11. Technology

10.12 Posi switching points

The *posi* switching points can be used to generate signals on binary outputs during movement. In contrast to the "electrical cam" which is *always* active between positions I60 and I61, the *posi* switching points are only evaluated during the running process blocks (movement) in which they were activated (L11, L12).

There are 4 *posi* switching points (S1 to S4). Each of these switching points can be used in several process blocks. Up to two switching points can be selected in one process block. Parameters L11 and L12 are used to select two switching points for process block no. 1.

Parameter	Possible Values
L11	Switching pt. A "0:inactive," "1:switch S1,"
L12	Switching pt. B "to "4:switch S4"

The characteristics of the switching points are specified in group N.. For example, the first switching point (S1) is described with N10 to N14.

Parameter	Possible Values
N10	S1-position Example: 113.00 mm
N11	S1-method „0:absolute," "1:rel.to start" or "2:rel.to endpos"
N12	S1-memory1 Selection: "0:inactive," "1:set,"
N13	S1-memory2 "2:clear," "3:toggle"
N14	S1-memory3

* Toggle = Change state each time switch is changed (i.e., "L" - "H" - "L" - "H" and so on)

The switching point position can be defined absolute (e.g., 1250.0 mm) or relative to the beginning or end of the running process block (N10, N11).

The switching points have no direct effect on the outputs. Instead, up to 3 **switch memories** can be set, reset or toggled in each switching point. Each binary output can be programmed to one of these three switching memories. F80=20:S-memory2 outputs S-memory 2 on output BA1.

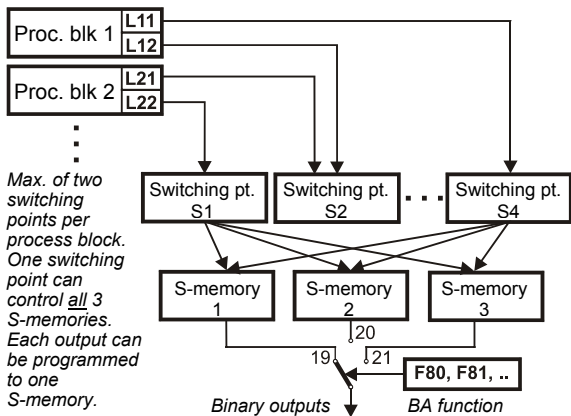

Example 1: In process block 2, binary output 2 (relay 2) is to be set 150 mm before the destination position and reset when the destination position is reached.

Solution: Two switching points are required (S1 and S2). Switching point S1 activates switch-memory 1 ("S-memory1") while switching point S2 deactivates the same memory.

Switching Point S1	Switching Point S2
N10=150 mm	N20=0 mm
N11=2:rel.to endpos	N21=1:rel.to enpos
N12=1:set S-memory 1	N22=2:clear S-memory 1

Switching points S1 and S2 are assigned to process block 2 in the L.. group.

L21 = Switching point S1, L22 = Switching point S2
Output BA2 is assigned to S-memory1 with F00=19.

Example 2: A paint pistol moves back and forth between two points. The inverter is to turn the pistol on/off with binary output BA1. Since it takes a long time to react, the pistol must be turned on ahead of time at distance a after the start of the process block and must be turned off at distance b before the end of the process block.

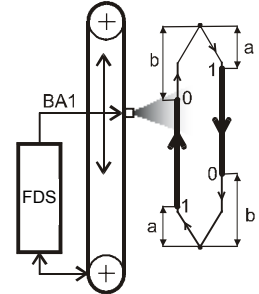

Solution: Two process blocks (position up and position down) and two switching points are required. The first switching point activates switching memory 1 ("S-memory1"). The second switching point deactivates the same memory.

Switching Point S1	Switching Point S2
N10=a (distance a)	N20=b (distance b)
N11=1:rel.to start	N21=2:rel.to endpos
N12=1:set S-memory 1	N22=2:clear (S-memory 1)

The same switching points are parameterized in both process blocks.

Process Block 1	Process Block 2
L11 = Switching point S1	L21 = Switching point S1
L12 = Switching point S2	L22 = Switching point S2

F80=19 assigns output BA1 to S-memory 1.

11 TECHNOLOGY

11.1 PID controller

The PID controller on analog input AE2 can be used as a technology controller for compensating rollers, pressure, throughput and similar. It is activated with G00=1.

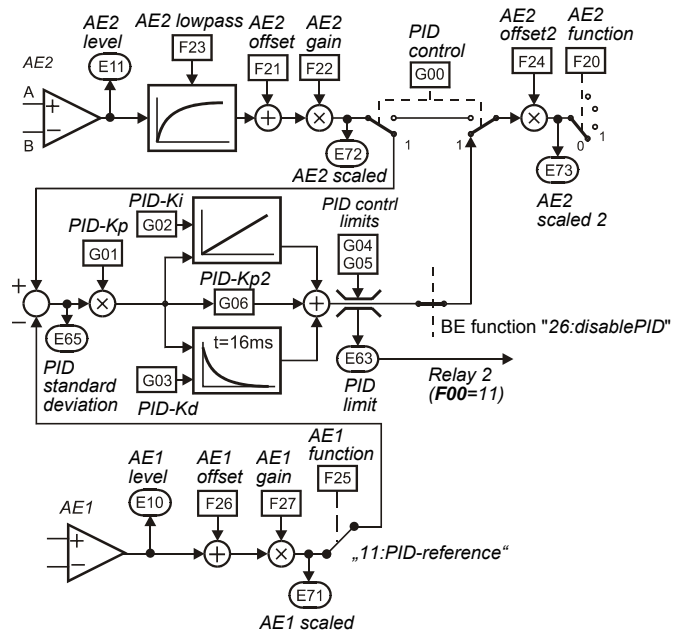

11. Technology

There are four ways to compare reference and actual values.

- Use of differential input AE2. The two signals are connected to "+" and "-" in relation to analog ground.
- A fixed reference value can be defined in **F21** (AE2 offset).
- AE1 can be programmed to **F25=11:PID-reference**.
- PID-reference via fieldbus (**E121**).

The low pass filter (smoothing, time constant **F23**) suppresses undesired high-frequency oscillations. The output of the PID controller is usually used as an additional reference value (**F20=1**). The binary input function "26:disable PID" (**F31** to **F35**) deactivates the controller. The controller output (i.e., adjustment variable) can be limited by **G04** and **G05**. Active limitation can be signaled on relay 2 (**F00=11**), for example. This can be used to indicate a malfunction in the process (e.g., tearing of wound material).

Important: Enable-off sets the output of the PID controller and the I portion to zero.

11.2 Winders

The standard models of series FDS 4000 frequency inverters contain functions for solving simple winding tasks (i.e., reel drives). This functionality is only available together with speed feedback (**B20=2**). The following tasks are supported. :

No.	Task	Diagram
1	Winding with diameter sensor at constant speed $v = \text{const}$	
2	Winding with indirect tension control at the M-max. limit.	
3	Winding with compensating rollers via speed offset and PID controller on AE2	
4	Winding with direct tension control with tension sensor on AE2	

When a material is wound and unwound, the speed progresses in reverse proportion to the diameter ($n \sim 1/D$). If there is no diameter sensor (tasks 2 to 4), the diameter is calculated by the inverter as $D \sim v\text{-master} / n\text{-motor}$ (**G11=1**) or obtained by integration of the roller deviation (**G11=2**). The maximum change in speed of the diameter is provided by **G16**. The current diameter is indicated in parameter **G19** (actual winding diameter). This can be output on the monitor output with **F40=5**. Depending on the task, the winding drive uses the following modes.

- Speed-controlled, **G10=1:n mode** (tasks 1 + 3).
- At the M-max. limit, **G10=2:M-Max mode** (tasks 2 + 4).

Simple tasks can also be solved with rotating field magnets. Cf. AE2 function **F20=8:M-rot.magnet**.

11.2.1 Diameter sensor on AE1/AE2

Winders or unwinders with constant circumferential speed. The diameter sensor is connected to the analog input. The primary parameters are listed below:

- **F20=7:wind.diameter** (for AE1: **F25**)
- **G10=1:n mode**
- **G11=0:AE2-measured**
- **G12** winder D-Min., **G13** winder D-Max.

Parameters **F21** and **F22** are used to assign the values *D-Min.* and *D-Max.* to the related sensor voltages *U-Min.* and *U-Max*

- **F21** = $- U\text{-Min.} \div 10 \text{ V} \times 100\%$ (AE2 offset)
- **F22** = $10 \text{ V} \div (U\text{-Max.} - U\text{-Min.}) \times 100\%$ (AE2 factor)

Since the reference value decreases with increasing diameter in accordance with the reciprocal value $1/D$, the control reference value is the highest possible speed with an empty roll.

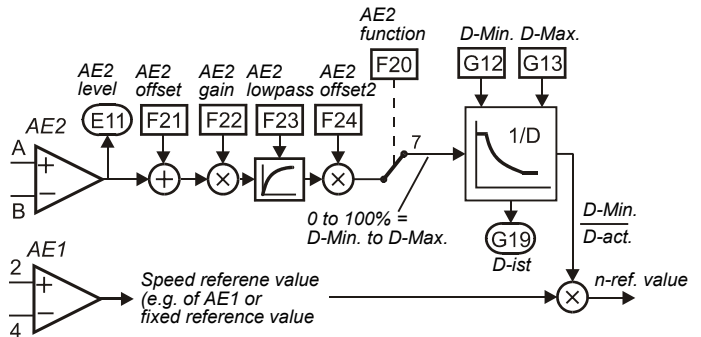

11.2.2 Indirect tension control at Mmax limit

Winders or unwinders with constant tension without extra sensors. The winding speed is specified by a master drive. The master reference value must be such that it precisely corresponds to the motor speed required there for *D-Min.* (i.e., empty roll). The master reference value must always be positive. See **E10** (AE1 level). If necessary, the direction of motor revolution must be adjusted with **D92**. The winding drive calculates the diameter in accordance with $D \sim v\text{-master} \div n\text{-motor}$ and affects the torque limit in proportion to *D*. The torque limit on AE2 or **C03** is the greatest possible torque with a full roll. The primary parameters are listed below:

- **G10=2:M-Max mode**
- **G11=1:n-line/n-motor**
- **G12** Winding D-Min., **G13** winding D-Max
- **G14** Winding D-ini
- **F20=2:torque-limit** or **C03**
- **D92** Reference value negation
- **G15** Override reference value

The speed reference value of a winder must always be greater than the master reference value so that the drive runs at the torque limit. This is ensured with the override reference value **G15** which is added to the master reference value. In contrast, an unwinder should never be allowed to start running automatically in the direction of unwinding. For this reason, the master reference value of AE1 is never provided unless it is a positive number.

Override reference value **G15** ensures that the material is tensed when the master reference value=0 (i.e., the unwinder attempts to rotate slowly against the direction of winding. The direction of motor revolution can be adjusted with **D92** or via a binary input. Cf. **F31=6**. The following figure illustrates how this process functions (see on the following page).

12. Synchronous Running, El. Gearbox

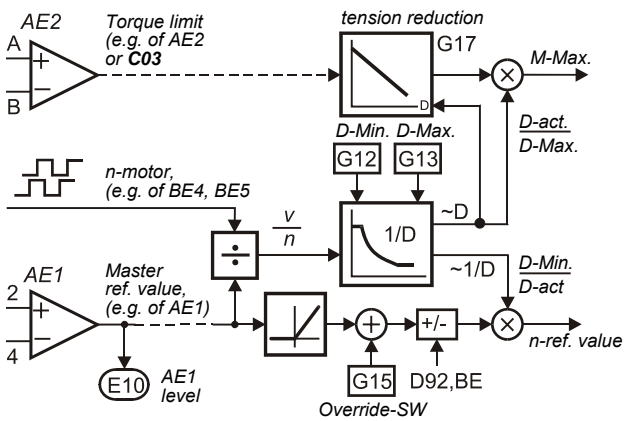

Before the winding process starts, the initial diameter must be set to **G14** via a binary input (e.g., **F31=29** for BE1). When the power is turned off, the current diameter (*D-act*) is saved in non-volatile memory. Incorrect calibration of the master reference value will cause *D-act* to drift away. If the master reference value is too high (e.g., due to **D02** being too high), *D-act* will also be too high! **G17** can be used to parameterize *tension reduction* with increasing diameter.

11.2.3 Winding with compensating roller

Winders or unwinders with constant tension provided by a compensating roller. The position of the compensating roller is measured and controlled via a PID controller on AE2. The winding speed is specified by a master drive. The winding drive calculates the diameter in accordance with $D \sim v \cdot \text{master} \div n \cdot \text{motor}$ and multiplies both the master reference value and the offset reference value with $1/D$. The primary parameters are listed below.

- **G10=1:n** mode
- **G11=1:n-line/n-motor**
- **G12** Winding D-Min., **G13** winding D-Max
- **G14** Winding D-ini
- **G00=1** (PID controller active)
- **G01** PID controller Kp, **G02** PID controller Ki.
- **F20=1:additional reference value**

Block circuit diagram:

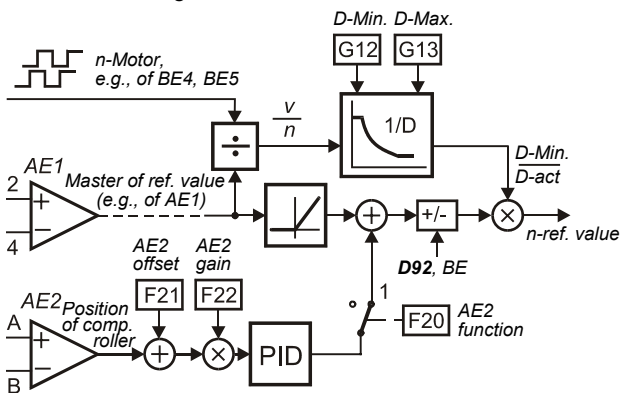

Instead of using **G11=1:n-line/n-motor** to calculate the diameter, **G11=2:roller** can also be used for a compensating roller. The deviation of the roller is measured with an analog input (**F20=12:wind.roller**). A speed feedback is not required. Integration of the diameter is controlled by the positive or negative deviation of the roller.

11.2.4 Winding with tension sensor

Tasks similar to winding with compensating roller but with the following differences.

- **G10=2:M-Max** mode
- **F20=2**: torque-limit
- **G15** Override reference value

When winding with tension sensors, it is often a good idea to use an external PID controller with integration and precontrol of the tension reference value.

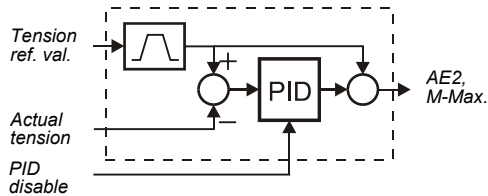

11.2.5 Compensation of fault variables

The effects of friction and inertia on the traction can be compensated for. The torque limit is offset by the friction used with **G40** and **G41**.

Compensation of inertia: The inertia torque of the full roll at D-Max must be converted to the motor shaft and entered in **C30** as a ratio of the inertia torque of the motor. The acceleration is obtained by differentiation of the encoder signal. The result can be smoothed with **G42**.

The variable diameter may also affect the gain of the speed controller. The gain between **C31*C35** at D-Min and **C31** at D-Max changes in proportion to the square of the diameter. The I portion is affected in the same way.

12 SYNCHRONOUS RUNNING, EL. GEARBOX

Using the synchronous running functionality, you can precisely synchronize two shafts. Different gear ratios are calculated without rounding errors. There are two signal sources which can be used as **master**.

- Incremental encoders (e.g., on a master drive)
- "Frequency" and "sign" signals (stepper motor simulation, only with **GB4001** and **EA4001** and **H20=3**)

There are 3 ways to handle the slave.

- FDS inverter with encoder feedback (**B20=2**) and an option board for the second encoder input (normal case)
- FDS inverter with SLVC (**B20=1**). For applications that do not require a high degree of accuracy.
- FDS inverter with V/f control (**B20=0**). For exact angle synchronous running with **reluctance motors**.

The electronic gearbox on the slave runs in mode **C60=1:speed**. Activation is handled by parameter **G20**.

12.1 Function overview

- Precise speed and angle ratio
- Gear ratio can be set as fraction
- Following error monitoring
- Free wheeling via binary input
- Precontrol for high dynamics
- No stationary angle error
- Angle offset via binary or analog inputs
- Fine adjustment of the gear ratio possible via AE2
- Angle synchronous running with reluctance motors
- Master signals of the incremental encoder or as frequency + sign (stepper motor format)

See chapter 18 for the **block circuit diagram** for synchronous running.

12. Synchronous Running, El. Gearbox

12.2 Connection of encoder

There are several ways to wire the master-slave connection. The primary factor is the level of the incremental encoder used (i.e., 5 V or 24 V).

With an FDS **master** with a 24 V motor encoder, the conventional encoder connection to BE4 and BE5 is usually used. Encoder tracks A and B and the reference ground are looped through to the slave.

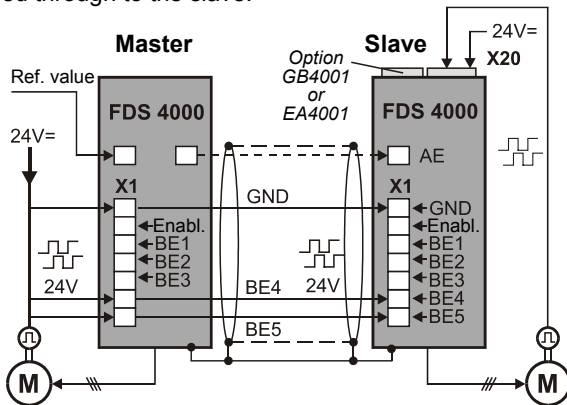

Depending on the type, the master incremental encoder is able to drive 10 to 20 slaves (see chap. 5 for technical specifications of the BEs).

The GB4001 option board can also be used with the master. The TTL/HTL-adjustable encoder output X21 of the GB4001 option can address up to 5 HTL slaves. The output signals on plug connector X21 must be set to the HTL level as shown in the configuration below (chap. 14.1). In the default setting, TTL signals are output.

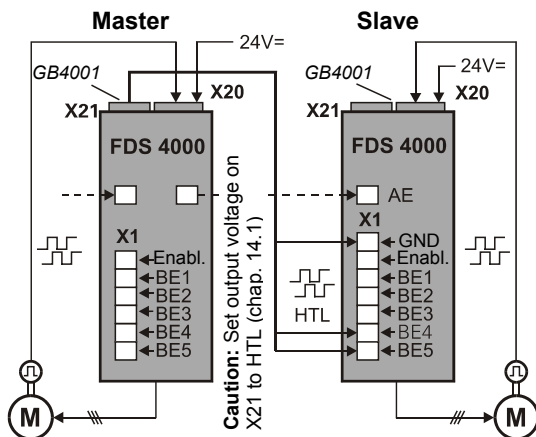

The master pulses usually have HTL level and arrive at the slave via inputs BE4 and BE5. Other configurations are also conceivable.

	Encoder Signals		Slave Connector		Par. G27	Par. B26
	Master ¹⁾	Slave ²⁾	Master	Motor		
1	5 V	5 V	-	-	-	-
2	5 V	24 V	X20	BE4 + 5	1	0
3	24 V	5 V	BE4 + 5	X20	0	1
4	24 V	24 V	BE4 + 5	X20	0	1
5	24 V	24 V	X20	BE4 + 5	1	0

¹⁾ Signals of the master ²⁾ Motor encoder slave

The following information applies to the slave.

- The connection of the motor encoder is specified in **B26**.
- The input for master signals is specified in **G27**.
- When the encoder is connected to BE4/BE5, the inputs must be programmed to **F34=14:encoder signal A** and **F35=15:encoder signal B**.
- When the encoder is connected to X20, **H20=2** must be set.
- If several slaves are supplied with TTL signals via EA/GB4001 over X20, each slave has a power requirement of 30 mA at 5 V (voltage drop, optocoupler ≈2 V, series resistance 100 Ω).

If the master supplies the position as **frequency** and **sign** (stepper motor simulation), evaluation is performed with the EA4001 or GB4001 option board (**H20=3**).

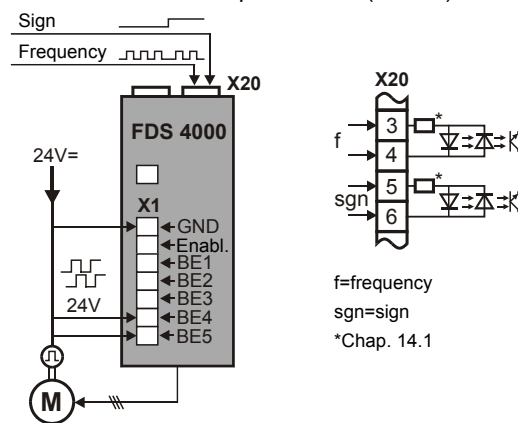

12.3 Connection of inputs and outputs

Compare block circuit diagram in chap. 18.

Binary inputs (parameters F31 to F35)

- 12:ext fault;
- 17:tip +; The slave is shifted to the positive direction in relation to the master. The speed is the result of the current speed reference value (AE1 or fixed reference value).
- 18:tip -; Same as "17:tip +" but in the negative direction.
- 27:syncFreeRun; Switch off synchronous running to run the drive with the analog reference value, for example.
- 28:syncReset; Current synchronous difference **G29** is reset.

Binary outputs (parameters F00 and F80, F81)

- 12:sync.diff.; The synchronous difference exceeds limit value **G24**.

Analog inputs AE2 (parameters F20, F25):

- 5:Override; The gear ratio is affected during operation (change every 250 msec).
- 13:sync.offset; Slave position is changed via analog voltage (100% = **G38**).
- 14:Sync. n-RV; External speed precontrol with analog reference value.

12.4 Commissioning of slave

- Specify mode **C60=1:speed** for slave.
- Commission slave separately from master (speed reference value).
- Activate el. gearbox with **G20=1** or **G20=2**.
- Specify input for master signals in **G27**.
- Parameterize input for master signals (X21: **H20** to **H23**; BE4/5: **F34=14**, **F35=15**, **F36**).
- Specify speed ratio **G22/G21**.
- Direction of rotation can be changed with **D92**.

12. Synchronous Running, El. Gearbox

12.5 Angle deviation

The current deviation between master and slave is indicated in **G29**. The angle of deviation is reset when:

- When voltage is turned on (power and 24 V) if **G20**<3
- Always for BE function "28:SyncReset"
- For enable, halt and quick stop. See **G25**.
- For BE function "27:SyncFreeRun." See **G25**.

The angle controller multiplies synchronous difference **G29** with **G23** (Kp.). The resulting speed offset is limited to \pm **G26** (n-correction-Max).

A continuous angle shift between master and slave can be implemented with the BE functions *Tip +* and *Tip -*. The speed difference is the current speed reference value (i.e., analog input AE1 or the fixed reference value). Another way to shift the angle is the AE function "13:synchron-offset."

The **dynamic angle deviation** during acceleration is reduced with **speed precontrol**.

- Usually, the master increments are differentiated and added as *speed forward feed* to the speed reference value.
Advantage: No extra wiring required
Disadvantage: The master must move first before the slave can react. The speed obtained by differentiation is smoothed with a low pass. ($T = G22/G21 * F36/H22 * 4$ msec if **G27**=0:BE-encoder. Otherwise $T = G22/G21 * H22/F36 * 4$ msec. In addition: $T \geq 16$ msec).
- The "14:Synchro reference value" function can be used to directly switch the speed reference value (post ramp) from the master to the analog input of the slave (**F20**=14). The function of the analog output **F40**=11:E07 n-postRmp can be used for this with the master. No ramp can be parameterized on the slave for the external precontrol. If the analog reference value is circuited in parallel on master and slave, no ramps may be active on the master.

12.6 Angle and speed synchronous running

With *angle synchronous running* (**G20**=2), all angle deviations are acquired and adjusted. However, this is not always desired. In *speed synchronous running mode* (**G20**=1), the angle controller can be partially or completely deactivated.

The following setting is used to limit synchronous difference **G29** to the value **G24**.

G20=1: speed synchron run
G23>0 (Kp synchronous running)

Although the speed ratio is precisely adhered to, the slave never attempts to catch up with a synchronous difference over **G24**. This is similar to a mechanical safety notching coupling.

Make the following selection for pure speed synchronization.

G24=0

The speed ratio is not mathematically precise.

12.7 Emergency off

The following measures are helpful in minimizing divergence of master and slave when the power goes off.

- Select master low voltage limit **A35** higher than that of the slave.
- Set master quick stop to **F38**=2.
- Link intermediate circuits between master and slave.
- Adapt master quick stop ramp (**D81**) and torque limits (**C04**) on the master and slave to the mass ratios.

Turning off the power while the enable is active causes the fault "46:low voltage". After power returns, a device initialization is performed which may take several seconds.

⇒ We recommend removing the enable at the same time the power is removed so that the inverter does not go into "fault mode".

12.8 Reference point traversing - slave

Reference point traversing permits you to automatically put the slave into a defined initial position.

Reference point traversing is specified with parameters **G31** to **G35**. Reference point traversing is started with a binary input (function **F31**=24:Start ref.).

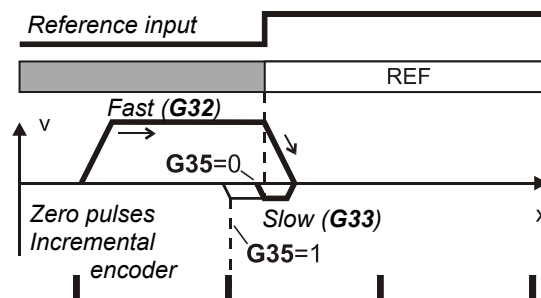



The drive moves at speed **G32** in direction **G31** until the reference switch (reference input) on a BE becomes active (function **F31**=23:Ref.input). The angle deviation is reset, and the drive halts.

If only one direction of revolution is permitted (**C02**), the drive moves in direction **C02** at speed **G33** until the *rising* edge of the reference switch. The reference direction (**G31**) is ignored in this case.

The current speed reference value ramps are used for referencing (i.e., usually **D00** and **D01**).

13. Parameter Description

A.. Inverter		E
Para. No.	Description	
	<p>5: 100Ohm 0.6kW 6: 30Ohm 0.15kW 7: 30Ohm 0.6kW</p> <div style="border: 1px solid black; padding: 5px; width: fit-content;"> <p>A20 1 to 7: This information is used to create a thermal model which determines the maximum permissible power which can be dissipated with the braking resistor. This protects the braking resistance from thermal overload. A thermal overload causes the fault "42:Temp.BrakeRes"</p> </div>	
A21	<p>Brake resistor resist.: Only with A20=1 (user defined), resistance value of the braking resistor used <i>Value range in Ω:</i> Depends on type, up to 600</p>	
A22	<p>Braking resistor rating: Only with A20=1 (user defined), capacity of the braking resistor used. Entering A22=0 KW automatically extends the ramps when DC link voltage is too high (if no braking resistor is connected, the fault "36:Highvoltage" is avoided.). <i>Value range in kW:</i> 0 to 150</p>	
A23	<p>Braking resistor therm.: Only with A20=1 (user defined), thermal time constant of the braking resistor <i>Value range in sec:</i> 0.1 to 40 to 100</p>	
A30•	<p>Operation input: Specifies the origin of the control signals (i.e., enable, direction of rotation and reference value) <i>0:</i> control interface (X1); Control signals (e.g., enable and so on) are generated via the X1 terminals. All binary inputs must be programmed accordingly. Fieldbus operation without <i>Drivecom</i> profile. <i>1:</i> serial (X3); Control signals (e.g., enable and so on) are generated from the PC (FDS Tool software). The inverter is connected to the PC via sub D plug connector X3 (RS 232-C interface). See chapter 9.9. Remote control via the PC requires that the enable input (X1.9) be high. <i>2:</i> fieldbus; The inverter is put into a drive-compatible mode for operation with communication. The device is either controlled exclusively via the bus (the BEs should be set to "0:inactive" or in mixed operation). Signals from the BEs (e.g., halt and limit switch (stop+, stop -) take priority over the fieldbus signals. If the control is performed only via the fieldbus, the input functions (i.e., F20, F25, F31 to F35, and F60 to F64) must be set to "0:inactive." Control of the drive via fieldbus requires that the enable input (X1.9) be high.</p>	
A31	<p>Esc-reset: Use the  key to acknowledge faults while they are being indicated. <i>0:</i> inactive; <i>1:</i> active; Faults can be acknowledged with .</p>	
A32	<p>Auto-reset: Faults which occur are acknowledged automatically. <i>0:</i> inactive; <i>1:</i> active; The inverter acknowledges some faults automatically. See chapter 17. Faults can be automatically acknowledged three times within a time period of 15 minutes (default setting). A fourth fault is not acknowledged automatically. Instead, relay 1 opens, and the fault must be acknowledged in some other way (i.e., enable, binary input F31 to F35=13, or  key A31). The automatic acknowledgment counter is reset. After three unsuccessful attempts at acknowledgment, the inverter ignores automatic acknowledgment and malfunctions. The time period for automatic acknowledgment can be parameterized from 1 to 255 min.</p>	
A33	<p>Time auto-reset: Time period for automatic acknowledgment. See A32. <i>Value range in min:</i> 1 to 15 to 255</p>	
A34	<p>Auto-start: Before you activate auto-start A34=1, check to determine whether safety requirements permit an automatic restart. Use only permitted when the standards or regulations pertaining to the system or machine are adhered to. <i>0:</i> inactive; After power-on, the enable must change from L level to H level to enable the drive (→ message "12:inhibited"). This prevents the motor from starting up unintentionally (i.e., machine safety). <i>1:</i> active; When auto-start is active, the drive can start running immediately (if enabled) after the power is turned on.</p>	
A35	<p>Low voltage limit: If the inverter is enabled and the DC-link voltage is less than the value set here, the inverter assumes fault "46:low voltage. " With three-phase devices, A35 should be approximately 85% of the network voltage so that any failures in a phase can be compensated for. <i>Value range in V:</i> Single phase: 120 to 300, three phase: 150 to 350 to 570</p>	
A36	<p>Mains voltage: Maximum voltage provided to the motor by the inverter. Usually the power voltage. Starting at this voltage, the motor runs in the field weakening range. This specification is important for optimum adjustment in control modes "sensorless vector-control" (B20=1) and "vector-control" (B20=2). <i>Value range in V:</i> Single phase: 140 to 230 to 250, three phase: 220 to 400 to 480</p>	
A37	<p>Reset memorized values: The six different following error counters E33 to E38 (e.g., maximum current, maximum temperature and so on) are reset.</p>	
A40• ¹⁾	<p>Read parabox: Read parameters from a Parabox or Controlbox <i>without</i> automatic storage <i>0:</i> inactive; <i>1 to 7:</i> active; For how it works, compare A01.</p>	

^P Speed depends on pole number **B10**; $f_{max} = 400$ Hz. With a 4-pole motor, this is 12000 rpm at 400 Hz.
• The power pack must be turned off before these parameters can be changed.
Italics These parameters are sometimes not shown depending on which parameters are set.
¹⁾ See result table in chap. 15. ²⁾ Only available when **D90≠1**
Parameters which are included in the *normal* menu scope (**A10=0**). For other parameters, select **A10=1:extended** or **A10=2:service**.
E Parameters marked with a "√" can be parameterized separately from each other in parameter record 1 and 2.

13. Parameter Description

A.. Inverter		E												
Para. No.	Description													
A41	<p>Select parameter set: Two parameter records are available. These can be selected via the binary inputs or directly via A41. The selected parameter record does not become active until the enable has been removed and after a maximum of 300 msec have passed. Some parameters retain their validity in both parameter record 1 and parameter record 2 (e.g., the posi. parameters in I, J and L). Parameters which can be programmed separately in parameter record 2 are indicated by a E between the coordinate and parameter name. See chapter 7.1.</p> <p>0: external; The active parameter record is selected via binary inputs BE1 to BE5. At least one of the parameters F30 to F34 must be set to 11 (parameter set-select) in both parameter records. Parameter record 1 is active when a LOW signal is present on BE. Parameter record 2 is active when a HIGH signal is present on BE.</p> <p>1: parameter set 1; The inverter uses parameter record 1. External selection is not possible.</p> <p>2: parameter set 2; The inverter uses parameter record 2. External selection is not possible.</p> <p>Caution: Parameter A41 is only provided for testing purposes. It is not saved with A00=1. Use a BE or the E101 parameter (bus access) if you want to switch parameter records during operation.</p>													
A42 ¹⁾	<p>Copy parameter set 1>2: Copies parameter record 1 to parameter record 2. The old values of parameter record 2 are overwritten. The procedure is started when the value changes from 0 to 1. The result is always "0:error free." The new parameter assignment must be stored in non-volatile memory with A00.</p> <p>0: error free;</p>													
A43 ¹⁾	<p>Copy parameter set 2>1: Same as A42 except parameter record 2 is copied to parameter record 1</p> <p>0: error free;</p>													
A50	<p>Tip: Only when C60≠2 (run mode≠position). Permits commissioning with minimum circuiting of the control terminal as long as A51 is entered.</p> <p>0: inactive; Normal operation</p> <p>1: active; The controller only requires a high signal on the "enable" input. All other binary control signals have no function when C60<2. The and keys can be used to accelerate the drive counterclockwise or clockwise to the speed set in A51. Since an enable is generated which has a higher priority than the additional enable, operation remains possible even when additional-enable = low via fieldbus.</p>													
A51	<p>Tip reference value: Only when C60≠2 (run mode≠position). Reference value for speed for commissioning without external circuiting of the control inputs. The "enable" input must be high! The current actual speed is shown on the right of the display. When A50=1 and A51 is in input mode (value flashing), A51 becomes active as continuous reference value. For behavior of enable and BEs, see A50.</p> <p><i>Value range in rpm: -12000^P ... 300^P ... 12000^P</i></p>	√												
A55	<p>Key hand function: Can be used to disable the MANUAL key on Controlbox for turning local operation on/off. For additional information, see Controlbox documentation (no. 441479).</p> <p>0: inactive; key has no function.</p> <p>1: local; key activates local operation. Device enabling is then handled exclusively by the keys "green I" and "red 0" . The and keys can be used to move backward and forward in the status display. Active local operation and active enable are indicated by LEDs on Controlbox. The reference speed results from A51 for speed mode and from I12 for POSI.</p> <p>CAUTION: When local operation is disabled with the key (LED goes off), the drive immediately switches back to the queued control signals (i.e., danger of unintentional startup!).</p>													
A80	<p>Serial address: Only when A10=2. Address for communication via X3 with FDS Tool and with master via USS protocol (see documentation: USS coupling for POSIDRIVE® and POSIDYN®, no. 441564)</p> <p><i>Value range: 0 to 31</i></p>													
A82	<p>CAN-baudrate: Sets the baud rate for the Kommubox CAN bus. Cf. CAN bus documentation no. 441562.</p> <table style="width: 100%; border: none;"> <tr> <td style="width: 25%;">0: 10 kBit/s</td> <td style="width: 25%;">2: 50 kBit/s</td> <td style="width: 25%;">4: 125 kBit/s</td> <td style="width: 25%;">6: 500 kBit/s</td> <td style="width: 25%;">8: 1000 kBit/s</td> </tr> <tr> <td>1: 20 kBit/s</td> <td>3: 100 kBit/s</td> <td>5: 250 kBit/s</td> <td>7: 800 kBit/s</td> <td></td> </tr> </table>	0: 10 kBit/s	2: 50 kBit/s	4: 125 kBit/s	6: 500 kBit/s	8: 1000 kBit/s	1: 20 kBit/s	3: 100 kBit/s	5: 250 kBit/s	7: 800 kBit/s				
0: 10 kBit/s	2: 50 kBit/s	4: 125 kBit/s	6: 500 kBit/s	8: 1000 kBit/s										
1: 20 kBit/s	3: 100 kBit/s	5: 250 kBit/s	7: 800 kBit/s											
A83	<p>Busaddress: Specifies the device address for use with the fieldbus (i.e., Kommubox). For permissible value range, see documentation of the applicable Kommubox. A83 has no effect on device programming via PC with FDS Tool or via the RS 232 interface with the USS protocol.</p> <p><i>Value range: 0 to 125</i></p>													
A84	<p>Profibus baudrate: When the FDS is used with the PROFIBUS-DP Kommubox, the baud rate found on the bus is <i>indicated (!)</i> here. Cf. PROFIBUS-DP documentation no. 441535.</p> <table style="width: 100%; border: none;"> <tr> <td style="width: 25%;">0: not found</td> <td style="width: 25%;">3: 45,45 kBit/s</td> <td style="width: 25%;">6: 500 kBit/s</td> <td style="width: 25%;">9: 6000 kBit/s*</td> </tr> <tr> <td>1: 9,6 kBit/s</td> <td>4: 93,75 kBit/s</td> <td>7: 1500 kBit/s</td> <td>10: 12000 kBit/s*</td> </tr> <tr> <td>2: 19,2 kBit/s</td> <td>5: 187,5 kBit/s</td> <td>8: 3000 kBit/s*</td> <td></td> </tr> </table> <p>* Available starting with Kommubox hardware version 06.2000</p>	0: not found	3: 45,45 kBit/s	6: 500 kBit/s	9: 6000 kBit/s*	1: 9,6 kBit/s	4: 93,75 kBit/s	7: 1500 kBit/s	10: 12000 kBit/s*	2: 19,2 kBit/s	5: 187,5 kBit/s	8: 3000 kBit/s*		
0: not found	3: 45,45 kBit/s	6: 500 kBit/s	9: 6000 kBit/s*											
1: 9,6 kBit/s	4: 93,75 kBit/s	7: 1500 kBit/s	10: 12000 kBit/s*											
2: 19,2 kBit/s	5: 187,5 kBit/s	8: 3000 kBit/s*												

^P Speed depends on pole number **B10**; $f_{max} = 400$ Hz. With a 4-pole motor, this is 12000 rpm at 400 Hz.

• The power pack must be turned off before these parameters can be changed.

Italics These parameters are sometimes not shown depending on which parameters are set.

1) See result table in chap. 15. 2) Only available when **D90≠1**

Parameters which are included in the *normal* menu scope (**A10=0**). For other parameters, select **A10=1:extended** or **A10=2:service**.

E Parameters marked with a "√" can be parameterized separately from each other in parameter record 1 and 2.

13. Parameter Description

B.. Motor		E																																								
Para. No.	Description																																									
B00•	<p>Motor-type: Motor selection from the motor data base. The STÖBER system motor used is specified with B00=1 to 29. B00=0 (user defined) is used for special windings or motors of other manufacturers.</p> <p>0: <i>user defined</i>; Number of poles, P, I, n, V, f and cos PHI must be specified in B10 to B16. It is essential to perform and store B41 (auto-tuning). Auto-tuning of the motor determines the winding resistors. This is required for optimum adjustment between inverter and motor.</p> <table border="0"> <tr> <td>1: 63K Y 0.12kW</td> <td>11: 80L Y 0.75kW</td> <td>17: 100K Y 2.2kW</td> <td>23: 132S D 5.5kW (400/690 V)</td> </tr> <tr> <td>2: 63K D 0.12kW</td> <td>12: 80L D 0.75kW</td> <td>18: 100K D 2.2kW</td> <td>24: 132M D 7.5kW (400/690 V)</td> </tr> <tr> <td>3: 63M Y 0.18kW</td> <td>13: 90S Y 1.1kW</td> <td>19: 100L Y 3kW</td> <td>25: 132L D 9.2kW (400/690 V)</td> </tr> <tr> <td>4: 63M D 0.18kW</td> <td>14: 90S D 1.1kW</td> <td>20: 100L D 3kW</td> <td>26: 169M D 11kW (400/690 V)</td> </tr> <tr> <td>5: 71K Y 0.25kW</td> <td>15: 90L Y 1.5kW</td> <td>21: 112M Y 4kW¹⁾</td> <td>27: 160L D 15kW (400/690 V)</td> </tr> <tr> <td>6: 71K D 0.25kW</td> <td>16: 90L D 1.5kW</td> <td>22: 112M D 4kW¹⁾</td> <td>28: 180M D 18.5kW (400/690V)</td> </tr> <tr> <td>7: 71L Y 0.37kW</td> <td></td> <td></td> <td>29: 180L D 22kW (400 / 690 V)</td> </tr> <tr> <td>8: 71L D 0.37kW</td> <td></td> <td></td> <td></td> </tr> <tr> <td>9: 80K Y 0.55kW</td> <td></td> <td></td> <td></td> </tr> <tr> <td>10: 80K D 0.55kW</td> <td></td> <td></td> <td></td> </tr> </table> <p>¹⁾ Only STÖBER motors with 230 V / 400 V (Δ/Y) winding.</p> <p>With 400 V / 690 V (Δ/Y) winding, select B00=0 (user setting).</p> <p>An "*" on the display means that at least one of the parameters (B53, B64 and B65) differs from the default setting of the STÖBER motor data base. FDS Tool also offers an external data base for motors of other manufacturers.</p> <div style="border: 1px solid black; padding: 5px; margin-top: 10px;"> <p>All necessary data are stored for these types of motors in a data base. This permits optimum adjustment between motor and inverter. Parameters B10 to B16 are not shown.</p> </div>	1: 63K Y 0.12kW	11: 80L Y 0.75kW	17: 100K Y 2.2kW	23: 132S D 5.5kW (400/690 V)	2: 63K D 0.12kW	12: 80L D 0.75kW	18: 100K D 2.2kW	24: 132M D 7.5kW (400/690 V)	3: 63M Y 0.18kW	13: 90S Y 1.1kW	19: 100L Y 3kW	25: 132L D 9.2kW (400/690 V)	4: 63M D 0.18kW	14: 90S D 1.1kW	20: 100L D 3kW	26: 169M D 11kW (400/690 V)	5: 71K Y 0.25kW	15: 90L Y 1.5kW	21: 112M Y 4kW ¹⁾	27: 160L D 15kW (400/690 V)	6: 71K D 0.25kW	16: 90L D 1.5kW	22: 112M D 4kW ¹⁾	28: 180M D 18.5kW (400/690V)	7: 71L Y 0.37kW			29: 180L D 22kW (400 / 690 V)	8: 71L D 0.37kW				9: 80K Y 0.55kW				10: 80K D 0.55kW				√
1: 63K Y 0.12kW	11: 80L Y 0.75kW	17: 100K Y 2.2kW	23: 132S D 5.5kW (400/690 V)																																							
2: 63K D 0.12kW	12: 80L D 0.75kW	18: 100K D 2.2kW	24: 132M D 7.5kW (400/690 V)																																							
3: 63M Y 0.18kW	13: 90S Y 1.1kW	19: 100L Y 3kW	25: 132L D 9.2kW (400/690 V)																																							
4: 63M D 0.18kW	14: 90S D 1.1kW	20: 100L D 3kW	26: 169M D 11kW (400/690 V)																																							
5: 71K Y 0.25kW	15: 90L Y 1.5kW	21: 112M Y 4kW ¹⁾	27: 160L D 15kW (400/690 V)																																							
6: 71K D 0.25kW	16: 90L D 1.5kW	22: 112M D 4kW ¹⁾	28: 180M D 18.5kW (400/690V)																																							
7: 71L Y 0.37kW			29: 180L D 22kW (400 / 690 V)																																							
8: 71L D 0.37kW																																										
9: 80K Y 0.55kW																																										
10: 80K D 0.55kW																																										
B10•	<p>Poles: Calculated from the nominal speed of the motor $p=2 (f \times 60/n_{Nom})$. Internally, the controller works with frequencies. Correct speed indication requires entry of the number of poles.</p> <p><i>Value range:</i> 2 to 4 to 16</p>	√																																								
B11•	<p>P-nominal: Nominal power as per nameplate.</p> <p><i>Value range in kW:</i> 0.12 ... (<i>depends on type</i>)</p>	√																																								
B12	<p>I-nominal: Nominal current as per nameplate. Remember type of connection (Y/Δ) of the motor must correspond to B14.</p> <p><i>Value range in A:</i> 0 ... (<i>depends on type</i>)</p>	√																																								
B13	<p>n-nominal: Nominal speed as per nameplate.</p> <p><i>Value range in rpm:</i> 0 to (<i>depends on type</i>) to 12000^P (^P Depends on pole number B10; $f_{max} = 400$ Hz)</p>	√																																								
B14•	<p>V-nominal: Nominal voltage as per nameplate. Remember type of connection (Y/Δ) of the motor must correspond to B12.</p> <p><i>Value range in V:</i> 0 to (<i>depends on type</i>) to 480</p>	√																																								
B15•	<p>f-nominal: Nominal frequency of the motor as per nameplate. The slope of the V/f curve and thus the characteristics of the drive are specified with parameters B14 and B15. The V/f curve determines the frequency (F15: f-nominal) at which the motor is operated with the nominal voltage (B14: V-nominal). Voltage and frequency can be increased linearly to more than the nominal point. The upper voltage limit is the power voltage which is present. STÖBER system motors up to model 112 offer the capability of star/delta operation. Operation with 400 V Δ makes it possible to increase power by the factor $\sqrt{3}$ and provide an expanded speed range with constant torque. With this type of connection, the motor has increased current requirements. The following must be ensured:</p> <ul style="list-style-type: none"> - The frequency inverter is designed for this power ($P_{\Delta} = \sqrt{3} \times P_Y$). - B12 (I-nominal) is parameterized to the appropriate nominal motor current ($I_{\Delta Nom} = \sqrt{3} \times I_{Y Nom}$). <p><i>Value range in Hz:</i> 10 to 50 to 330</p>	<div style="margin-top: 10px;"> <p>Motor circuits</p> <p>Y circuit</p> <p>Δ circuit</p> </div>																																								
B16	<p>cos PHI: The cos Phi of the nameplate of the motor is required for control.</p> <p><i>Value range:</i> 0.50 to (<i>depends on type</i>) to 1</p>	√																																								

^P Speed depends on pole number **B10**; $f_{max} = 400$ Hz. With a 4-pole motor, this is 12000 rpm at 400 Hz.

• The power pack must be turned off before these parameters can be changed.

Italics These parameters are sometimes not shown depending on which parameters are set.

1) See result table in chap. 15. 2) Only available when **D90**≠1

Parameters which are included in the *normal* menu scope (**A10**=0). For other parameters, select **A10**=1:*extended* or **A10**=2:*service*.

E Parameters marked with a "√" can be parameterized separately from each other in parameter record 1 and 2.

13. Parameter Description

B.. Motor		E
Para. No.	Description	
B20•	<p>Control mode: Specifies the type of motor control.</p> <p>0: <i>V/f-control</i>; V/f control changes voltage and frequency proportionally to each other so that machine flow remains constant. Utilized, for example, when reluctance motors or several motors are used with one inverter.</p> <p>1: <i>sensorless vector-control (SLVC)</i>; Vector control without feedback. Much better speed accuracy and dynamics. B31, B32 and C30 can be used to manipulate dynamic reactions.</p> <p>2: <i>vector-control feedback</i>; Vector control with feedback. The signals of the speed feedback are evaluated by the inverter via binary inputs BE4/BE5, or an option board (plug connector X20). First case: B26=0, F34=14 and F35=15 must be parameterized. Second case: B26=1 and H20=2 must be parameterized. For commissioning, see chap. 9.6.</p>	√
B21•	<p>V/f-characteristic: Effective regardless of the control mode selected in B20.</p> <p>0: <i>linear</i>; Voltage/frequency characteristic is linear. Suitable for all applications.</p> <p>1: <i>square</i>; Square characteristic for use with fans and pumps</p>	√
B22	<p>V/f-gain: Offset factor for the slope of the V/f curve</p> <p>The slope for V/f-gain=100% is specified by V-nom. (B14) and f-nom. (B15).</p> <p><i>Value range in %:</i> 90 to 100 to 110</p>	√
B23	<p>Boost: Only effective when B20=0 (V/f-control)</p> <p>Boost means an increase in voltage in the lower speed range which provides more startup torque. With a boost of 100%, nominal motor current begins flowing at 0 Hz. Determination of required boost voltage requires that the stator resistance of the motor be known. If B00=0 (user defined), it is essential to perform B41 (autotuning). If B00=1 to 29, the stator resistance of the motor is specified by the motor selected.</p> <p><i>Value range in %:</i> 0 to 10 to 400</p>	√
B24•	<p>Switching frequency: The noise emission of the drive is reduced by changing the switching frequency. However, since increasing the switching frequency also increases loss, permissible nominal motor current (B12) must be reduced if the switching frequency is increased.</p> <p>At a switching frequency of 16 kHz and $V_{Mains} = 400$ V, the inverter is able to supply a continuous current of 46% of its nominal current. At 8 kHz, it can supply 75%. For applications starting with 200 Hz, the switching frequency must be set to 8 kHz. Starting with software version 4.5B, the clock pulse frequency is automatically reduced based on the thermal model (E22).</p> <p><i>Value range in kHz:</i> 4, 6, 8 to 16 (adjustable in 2 kHz increments)</p>	√
B25•	<p>Halt flux: Only if B20≠2. B25 specifies whether the motor remains powered during halt and quick stop when the brakes have been applied. Particularly useful for positioning. Cf. parameter L10. After a HALT, the motor remains fully powered for the time B27. Output signal "22:ready for reference value" indicates that the magnetic field is being generated.</p> <p>0: <i>inactive</i>; When the brakes are applied (<i>halt</i>, <i>quick stop</i> or due to process block with L10=1, for example), power is withdrawn from the motor, and the motor is demagnetized. The advantage of this is improvement of thermal motor balance since the motor has time to cool off during the pauses. The disadvantage of this is the increased time required for remagnetization (i.e., rotor time constant, approx. 0.5 sec). The inverter automatically determines how much time is required and adds this to brake release time F06.</p> <p>1: <i>active</i>; Default setting. Magnetization current flows through the motor and speeds up reaction to brake release. Disadvantage: The motor heats up, and the magnetization current can be up to 40% of the nominal current depending on the size of the motor.</p> <p>2: 75%; Current reduced to 75%. Otherwise same as B25=0.</p> <p>3: 50%;</p> <p>4: 25%;</p>	√
B26•	<p>Motor-encoder: Only if B20=2 (vector control). B26 specifies which encoder input will be used for motor control. The encoder increments are specified with F36 or H22. Regardless of B26, the master encoder is set for synchronous operation (G20=1) with G27 and the POSI encoder (C60=2) is set with I02.</p> <p>0: BE-Encoder; Motor encoder (24 V) is connected to binary inputs BE4 and BE5. Remember F34=14 and F35=15 as well as F36 (BE increments)!</p> <p>1: X20; Motor encoder (5 V or 24 V) on option slot X20 (option boards GB4000, EA4000, SSI4000, GB4001 and EA4001). Remember H20=2:Encoder In and H22 (X20 increments).</p>	√
B27	<p>Time halt flux: When a reduction of halt flux B25 occurs, the full magnetization current is still retained for time B27 when the brakes are applied and the power pack is active (e.g., HALT signal or process block-specific).</p> <p><i>Value range in sec:</i> 0 to 255</p>	√

P Speed depends on pole number **B10**; $f_{max} = 400$ Hz. With a 4-pole motor, this is 12000 rpm at 400 Hz.

• The power pack must be turned off before these parameters can be changed.

Italics These parameters are sometimes not shown depending on which parameters are set.

1) See result table in chap. 15.

2) Only available when **D90≠1**

Parameters which are included in the *normal* menu scope (**A10=0**). For other parameters, select **A10=1:extended** or **A10=2:service**.

E Parameters marked with a "√" can be parameterized separately from each other in parameter record 1 and 2.

13. Parameter Description

B.. Motor		E
Para. No.	Description	
B30	Addit.motor-operation: Only if B20=0 (V/f-control). For multiple-motor operation. Permits an additional motor to be connected to the enabled inverter. Motor voltage is briefly reduced to prevent overcurrent switchoff. <i>0: inactive;</i> <i>1: active;</i>	√
B31	Oscillation damping: When idling, large motors may tend to sympathetic vibration. Increasing the parameter B31 damps these oscillations when B20=2:SLVC . Values from 60 to 100% are suitable for difficult drives. With B20=2:Vector Control , B31 limits the possibility, during generator operation, of using the increase in the rise of DC link voltage to increase magnetization and thus braking torque. This can have a positive effect on smoothness of running when the drive is alternating between motor and generator operation at a constant higher speed. <i>Value range in %: 0 to 30 to 100</i>	√
B32	SLVC-dynamics: B32 can be used to manipulate the speed at which SLVC reacts to changes in load. B32=100% means greatest dynamics. <i>Value range in %: 0 to 70 to 100</i>	√
B40 ^{•1)}	Phase test: <i>0: inactive;</i> <i>1: active;</i> Tests motor symmetry in increments of 60°. The following points are checked: - Connection of phases U, V and W - Symmetry of the winding resistance of the phases U, V and W. If a winding resistor deviates by ±10%, the inverter reports " 19:symmetry ". - Type of connection of the motor. If a STÖBER system motor has been selected with parameter B00=1 to 28, the type of connection of the selected STÖBER system motor (i.e., star/delta) is compared with that of the connected motor. Deviations are reported with " 20:motorConnect ." The function is started when the level on the input enable (X1.9) changes from low to high. Exiting the parameter requires another low signal on the enable.	
B41 ^{•1)}	Autotuning: Determination of the stator resistance B53 . Important for optimum motor control. <i>0: inactive;</i> <i>1: active;</i> Stator resistance B53 is measured. The function is started when the level on the input enable (X1.9) changes from low to high. Exiting the parameter requires another low signal on the enable. A00=1 is used to save the measuring results in non-volatile memory. The HALT signal may not be present and the extra enable must be present. B00=0. Be sure to autotune motor or enter R1-motor B53 directly. Important for optimum adjustment of inverter and motor. B00=1 to 29, autotuning of the motor is not required. Values are stored in the motor data base.	
B53	R1-motor: Stator resistance of the motor winding, $R1=R_{u-v}/2$. Usually only entered for non STÖBER motors or autotuning with B41 . In the Y circuit, B53 directly corresponds to the branch resistance. In the Δ circuit, 1/3 of the branch resistance must be entered. With STÖBER motors, B53 should usually not be changed. The resistance of a cold coil must be entered with an extra 10% (factor 1,1). R1 is required for correct functioning of the vector control (SLVC and VC). Value is adjusted with B41 (autotuning). An "*" indicates deviation from the STÖBER motor data base. <i>Value range in Ω: 0.01 to depends on type to 327.67</i>	√
B64	Ki-IQ (moment): Only when B20=2 . Integral gain of the torque controller. <i>Value range in %: 0 to depends on type to 400</i>	√
B65	Kp-IQ (moment): Only when B20=2 . Proportional gain of the torque controller. <i>Value range in %: 0 to depends on type to 400</i>	√
C.. Machine		E
Para. No.	Description	
C00	n-Min: Only if C60≠2 (run mode≠position). Minimum permissible speed. The speed is related to the motor shaft speed. Reference values less than n-Min are ignored and raised to n-Min. <i>Value range in rpm: 0 to C01</i>	√
C01	n-Max: Maximum permissible speed. The speed is related to the motor shaft speed. Reference values over n-Max are ignored and limited to n-Max. <i>Value range in rpm: C00 to 3000^P to 12000^P (P = depends on poles B10; f_{max} = 400 Hz)</i>	√
C02 [•]	Perm. direction of rotat.: Only if C60≠2 (run mode≠position). Determines the permissible direction of rotation. The direction of rotation can be specified via the binary inputs. <i>0: clockwise & counter-clockwise;</i> <i>1: clockwise;</i> <i>2: counter-clockwise;</i>	√

^P Speed depends on pole number **B10**; f_{max} = 400 Hz. With a 4-pole motor, this is 12000 rpm at 400 Hz.

• The power pack must be turned off before these parameters can be changed.

Italics These parameters are sometimes not shown depending on which parameters are set.

1) See result table in chap. 15.

2) Only available when **D90≠1**

Parameters which are included in the *normal* menu scope (**A10=0**). For other parameters, select **A10=1:extended** or **A10=2:service**.

E Parameters marked with a "√" can be parameterized separately from each other in parameter record 1 and 2.

13. Parameter Description

C.. Machine		E
Para. No.	Description	
C03	M-Max 1: Maximum torque in % of nominal motor torque. The active torque limit can be further reduced with an analog input (see F25=2). If the maximum torque is exceeded, the controller responds with the message "47:drive overload." See also remarks for C04 . <i>Value range in %:</i> 0 to 150 to 400%* * Value is limited by the maximum inverter current.	√
C04	M-Max 2: Additional torque limit. You can switch between C03 and C04 with a binary input (F3..=10:torque select) or automatically when startup mode= cycle characteristic (C20=2). See chap. 9.2. Remarks: Since C04 is always active for a quick stop , C04 ≥ C03 should usually apply! <i>Value range in %:</i> 0 to 150 to 400%* * Value is limited by the maximum inverter current.	√
C10	Skip speed 1: Only if C60 ≠2 (run mode≠position). Prevents prolonged use of the drive in a frequency range which produces mechanical resonance. The drive goes through the entered speeds and tolerance band of ±0.4 Hz with the decel-quick ramp (D81). The four "skip speeds" can be specified next to each other. <i>Value range in rpm:</i> 0 to 12000 ^P (^P depends on poles B10 ; f _{max} = 400 Hz)	√
C11	Skip speed 2: See C10 . <i>Value range in rpm:</i> 0 to 12000 ^P	√
C12	Skip speed 3: See C10 . <i>Value range in rpm:</i> 0 to 12000 ^P	√
C13	Skip speed 4: See C10 . <i>Value range in rpm:</i> 0 to 12000 ^P	√
C20•	Startup mode: Determines the startup behavior of the drive <i>0:</i> standard; Default setting. Separate from control mode (B20). <i>1:</i> load start; Only if B20=1 (sensorless VC). For machines with increased breakaway torque. The motor torque is increased to M-load start (C21) during the time t-load start (C22). After expiration of this time, the inverter uses the standard ramp again. <i>2:</i> cycle characteristic; Effective separately from the control mode (B20). - Automatic switch between the specified torque limits M-Max 1 (C03) and M-Max 2 (C04). M-Max 1 applies during constant travel. M-Max 2 applies during the acceleration phase. - If B20=1 (sensorless vector control), a torque precontrol procedure is performed (i.e., the inverter calculates the required torque from the motor type specified (B00) and the ratio of load/motor inertia (C30). This calculated torque is then given to the drive. <i>3:</i> capturing; Only if B20=1 . A rotating motor is connected to the inverter. The inverter determines the actual speed of the motor, synchronizes itself, and specifies the appropriate reference value.	√
C21	M-load start: Only if C20=1 (load start). Specification of the torque for the load start. <i>Value range in %:</i> 0 to 100 to 400	√
C22	t-load start: Only if C20=1 . Time for the load start with the torque defined in C21 . <i>Value range in sec:</i> 0 to 5 to 9.9	√
C30	J-mach/J-motor: Ratio of the inertia of load to motor. This factor is effective for all control modes and is important for optimization between inverter and motor (i.e., dynamics). Entry is not mandatory. Remarks: In winding mode, the effective inertia torque is calculated for C30 ≥ 1.5 to the fourth power with the winding diameter for compensation of the acceleration torque. The following applies: J (D-Min) = 1.5 * J-motor, J (D-Max) = C30 * J-motor. The torque supplied by the drive is increased so that traction remains constant and extra torque is available for acceleration. <i>Value range:</i> 0 to 1000	√
C31	n-controller Kp: Only if B20=2 (vector control with feedback). Proportional gain of the speed controller. The internal gain also depends on the number of poles (default setting is for 4 poles). Remarks: In winding mode (G10 >0), the Kp gain with the winding diameter is quadratically reduced from C31 for D-Max down to C31 * C35 for D-Min. <i>Value range in %:</i> 0 to 60 to 400	√
C32	n-controller Ki: Only if B20=2 . Integral gain of the speed controller. Reduce C32 when overshwinging occurs in the target position. <i>Value range in %:</i> 0 to 30 to 400	√
C35	n-control. Kp standstill: Without winders: C31 and C32 are multiplied by C35 as soon as the motor speed drops below C40 . With winders: The formulas described under C31 and C32 apply. <i>Value range in %:</i> 5 to 100	√
C40	n-window: If F00=3 (relay 2 as signal relay for "3:reference value-reached") or F00=2 (relay 2 as signal contact for speed "2:standstill"), the reference value is considered achieved in a window of reference value ± C40 , and relay 2 closes. A halting brake is not activated as long as [n] > C40 . <i>Value range in rpm:</i> 0 to 30 to 300 ^P	√

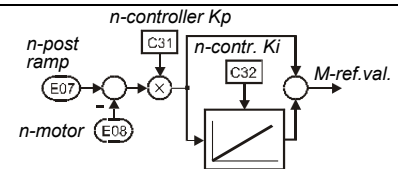

^P Speed depends on pole number **B10**; f_{max} = 400 Hz. With a 4-pole motor, this is 12000 rpm at 400 Hz.

• The power pack must be turned off before these parameters can be changed.

Italics These parameters are sometimes not shown depending on which parameters are set.

1) See result table in chap. 15.

2) Only available when **D90**≠1

Parameters which are included in the *normal* menu scope (**A10**=0). For other parameters, select **A10**=1:extended or **A10**=2:service.

E Parameters marked with a "√" can be parameterized separately from each other in parameter record 1 and 2.

13. Parameter Description

C.. Machine		E
Para. No.	Description	
C41	Operating range n-Min: Parameters C41 to C46 can be used to specify an operating area. An output (F00=6) can be used to signal that these values have been exceeded. All area monitoring procedures are performed at the same time. If area monitoring is not required, the minimum parameters must be set to the lower-limit values, and the maximum parameters must be set to the upper-limit values. Cf. chapter 9.3. When C49=0 , operating-range monitoring is suppressed when the motor is not powered and during acceleration/braking procedures. When C48=1 , amount generation is activated. <i>Value range in rpm: 0 to C42</i>	√
C42	Operating range n-Max: See C41 . <i>Value range in rpm: C41 to 6000^P to 12000^P (^P depends on poles B10; f_{max} = 400 Hz)</i>	√
C43	Operating range M-Min: See C41 . <i>Value range in %: 0 to C44</i>	√
C44	Operating range M-Max: See C41 . <i>Value range in %: C43 to 400</i>	√
C45	Operating range X-Min.: See C41 . Monitors range defined in C47 . <i>Value range in %: -400 to 0 to C46</i>	√
C46	Operating range X-Max.: See C41 . Monitors range defined in C47 . <i>Value range in %: C45 to 400</i>	√
C47	Operating range C45/C46: Defines the range to be monitored. 0: E01 P-motor; 5: E22 i2t-device; 10: E71 AE1-scaled; 1: E02 M-motor; 6: E23 i2t-motor; 11: E72 AE2-scaled; 2: E10 AE1-level; 7: E24 i2t-braking resistor; 12: E73 AE2-scaled 2; 3: E11 AE2-level; 8: E62 actual M-Max; 13: E14 BE5-frequency RV 4: E16 analog-output1-level; 9: E65 PID-error; 14: E08 n-motor; (% ref. to C01)	√
C48	Operating range of amount C47: 0: <i>absolute</i> ; First, the amount is generated from the signal selected in C47 . Example: C47=AE2 ; C45=30% ; C46=80% . The operating range is -80% to -30% and +30% to +80%. 1: <i>range</i> ; The signal selected in C47 must be located in range C45 to C46 . Example: C47=AE2 , C45= -30% , C46= +10% . The operating range is -30% to +10%.	√
C49	Operating range accel&ena: 0: <i>inactive</i> ; During acceleration or deactivated enable, the "operating range" signal for the binary outputs is set to "0"=ok. The three ranges are only monitored during stationary operation (compatible with device software V 4.3). 1: <i>active</i> ; The operating range is always monitored.	√
C50	Display function: Only if C60≠2 (operating mode≠position). Parameters C50 to C53 can be used to design the first line of the display as desired. See chapter 6.1. Eight characters are available for a number, and 8 characters are available for any unit. Display value=raw value/display factor. 0: <i>n2 & I-motor</i> ; 1: <i>E00 I-motor</i> ; The inverter supplies the actual motor current in amperes as the raw value. 2: <i>E01 P-motor</i> ; The inverter supplies as the raw value the actual active power as a percentage of the nominal motor power. 3: <i>E02 M-motor</i> ; As the raw value, the inverter supplies the actual motor torque as a percentage of the nominal motor torque. 4: <i>E08 n-motor</i> ; The inverter supplies the actual speed in rpm as the raw value. If V/f control (B20=0) and sensorless vector control (B20=1), the frequency (i.e., motor speed) output by the inverter is indicated. Only with vector control with feedback (B20=2) is the real actual speed indicated.	√
C51	Display factor: Only if C60≠2 . Raw value (C50) is divided by the value entered here. <i>Value range: -1000 to 1 to 1000</i>	√
C52	Display decimals: Only if C60≠2 . Number of positions after the decimal point for the value in the display. <i>Value range: 0 to 5</i>	√
C53	Display text: Only if C60≠2 (operating mode≠position) and if C50>0 . Text for customer-specific unit of measure in the operating display (e.g., "units/hour"). Maximum of 8 positions. Can only be entered with FDS Tool.	√
C60•	Run mode 1: <i>speed</i> ; Reference value for speed, conventional operating mode. 2: <i>position</i> ; Position control activated. When enable signal on X1.9, the position controller is turned on, and the current position is maintained. Full functionality of the position controller is only available with incremental encoders (B20=2). If C60=2 , group "D. reference value" is completely faded out. When the mode is switched from speed to position, the reference position is lost. With the <i>SSI-4000</i> option board, a non-acknowledgeable fault (" <i>37:n-feedback</i> ") is triggered after the switch to C60=2 . → Save values with A00 , and turn power off and on.	√

^P Speed depends on pole number **B10**; f_{max} = 400 Hz. With a 4-pole motor, this is 12000 rpm at 400 Hz.

• The power pack must be turned off before these parameters can be changed.

Italics These parameters are sometimes not shown depending on which parameters are set.

1) See result table in chap. 15.

2) Only available when **D90≠1**

Parameters which are included in the *normal* menu scope (**A10=0**). For other parameters, select **A10=1:extended** or **A10=2:service**.

E Parameters marked with a "√" can be parameterized separately from each other in parameter record 1 and 2.

13. Parameter Description

D.. Reference Value		Group D is not shown in run mode C60=2:position.	E
Para. No.	Description		
D00	Reference value accel: Acceleration ramp for analog reference value inputs. Is only used for specification of reference value via terminal strip X1 and motor potentiometer. – Voltage, current via analog input 1 (X1.2 to X1.4) – Frequency via binary input BE5 (X1.8 to X1.14) – Motor potentiometer via the binary inputs (D90=1) <i>Value range in sec/150 Hz * D98: 0 to 3 to 3000</i>		√
D01	Reference value decel: Deceleration ramp for analog reference value inputs. Is only used for specification of reference value via terminal strip X1 and motor potentiometer. – Voltage, current via analog input 1 (X1.2 to X1.4) – Frequency via binary input BE5 (X1.8 to X1.14) – Motor potentiometer via the binary inputs (D90=1) <i>Value range in sec/150 Hz * D98: 0 to 3 to 3000</i>		√
D02 ²⁾	Speed (max. ref. value)²⁾: Parameters D02 to D05 can be used to specify as desired the relationship between analog reference value and speed with a reference value characteristic curve. D02: Speed achieved with the maximum reference value (D03) <i>Value range in rpm: 0 to 3000^P to 12000^P (^P Depends on pole number B10; f_{max} = 400 Hz)</i>		√
D03 ²⁾	Reference value-Max.²⁾: Reference value to which the speed (max. RV) (D02) is assigned. Percentage of the analog reference value (10 V=100%) at which the maximum speed (D02) is achieved. <i>Value range in %: D05 to 100</i>		√
D04 ²⁾	Speed (min. ref. value)²⁾: Speed achieved with minimum reference value (D05). <i>Value range in rpm: 0 to 12000^P (^P Depends on pole number B10; f_{max} = 400 Hz)</i>		√
D05 ²⁾	Reference value-Min.²⁾: Reference value to which the speed (min. RV) (D04) is assigned. Percentage of the analog reference value (10 V=100%) at which the minimum speed (D04) is achieved. <i>Value range in %: 0 to D03</i>		√
D06 ²⁾	Reference value offset²⁾: Corrects an offset on analog input 1 (X1.2 to X1.4). When the ref. value is 0, the motor may not be permitted to rotate. If a revolution occurs anyway, this value must be entered with reversed sign as the offset (e.g., if param. E10 shows 1.3%, D06 must be parameterized to -1.3%). The value range is ±100%. While the ref. value offset is being entered, the current value of the analog input is shown at the same time. <i>Value range in %: -100 to 0 to 100</i>		√
D07 ²⁾	Reference value enable²⁾: When the minimum reference value (D05) is set to a value greater than 1%, an enable can be derived from the reference value output. <i>0: inactive;</i> <i>1: active;</i> An additional enable is derived from the reference value on analog input 1. If the reference value enable is high, the output is greater than or equal to the minimum reference value (D05). If the reference value enable is low, the output is less than the minimum reference value (D05).		√
D08 ²⁾	Monitor reference value²⁾: Monitors reference value output. Monitors for wire break. Ref. value monitoring will only function if the minimum reference value specified in D05 is greater than or equal to 5% (D05 ≥ 5%). <i>0: inactive;</i> <i>1: active;</i> If the reference value output is 5% less than the minimum permissible reference value (D05), the inverter shows "43:RV wire brk."		√
D09 ²⁾	Fix reference value no.: Selection of a fixed reference value <i>0: external selection via binary inputs and BE functions RV-select 0 to 2</i> <i>1 to 7: fixed selection of fixed reference value. BE inputs are ignored.</i>		√
D10 ²⁾	Accel 1²⁾: Up to 7 fixed reference values/ramp records can be defined per parameter record. Selection is made via the binary inputs. At least one binary input must be programmed to reference value selector (e.g., F31=1:RV-select0). The reference value selector is used to assign the fixed reference values or ramp records to the signals of the binary inputs. The result of the binary coding is shown in E60 (0 to 7). The ramp records accel 1 to 7 / decel 1 to 7) are only active in connection with the assigned fixed reference values 1 to 7. Accel 1: Acceleration time for ramp record 1 as related to 150 Hz. <i>Value range in sec/150 Hz * D98: 0 to 6 to 3000</i>		√
D11 ²⁾	Decel 1²⁾: Deceleration time for ramp record 1 as related to 150 Hz. <i>Value range in sec/150 Hz * D98: 0 to 6 to 3000</i>		√
D12 ²⁾	Fix reference value 1²⁾: Selection is made parallel to ramp record 1. (Accel 1 / decel 1) via the binary inputs <i>Value range in rpm: -12000^P to 750^P to 12000^P</i>		√
D20 ²⁾	Accel 2²⁾: Acceleration time for ramp rec. 2 as related to 150 Hz. <i>Value range in sec/150 Hz * D98: 0 to 9 to 3000</i>		√

No.	Accel	Decel	Reference Value
0	D00	D01	Analog, freq,...
1	D10	D11	Fixed RV 1
2	D20	D21	Fixed RV 2
⋮	⋮	⋮	⋮
7	D70	D71	Fixed RV 7

^P Speed depends on pole number **B10**; f_{max} = 400 Hz. With a 4-pole motor, this is 12000 rpm at 400 Hz.
 • The power pack must be turned off before these parameters can be changed.
Italics These parameters are sometimes not shown depending on which parameters are set.
 1) See result table in chap. 15. 2) Only available when **D90≠1**
 Parameters which are included in the *normal* menu scope (**A10=0**). For other parameters, select **A10=1:extended** or **A10=2:service**.
E Parameters marked with a "√" can be parameterized separately from each other in parameter record 1 and 2.

13. Parameter Description

D.. Reference Value		Group D is not shown in run mode C60=2:position.	E															
Para. No.	Description																	
D21 ²⁾	Decel 2²⁾ : Deceleration time for ramp rec. 2 as related to 150 Hz. <i>Value range in sec/150 Hz * D98: 0 to 9 to 3000</i>		√															
D22 ²⁾	Fix reference value 2²⁾ : Selection is made parallel to ramp rec. 2. (Accel 2/dec. 2) via the binary inputs <i>Value range in rpm: -6000 to 1500 to 6000</i>		√															
D30 ²⁾	Accel 3²⁾ : Acceleration time for ramp rec. 3 as related to 150 Hz. <i>Value range in sec/150 Hz * D98: 0 to 12 to 3000</i>		√															
D31 ²⁾	Decel 3²⁾ : Deceleration time for ramp rec. 3 as related to 150 Hz. <i>Value range in sec/150 Hz * D98: 0 to 12 to 3000</i>		√															
D32 ²⁾	Fix reference value 3²⁾ : See D12 . <i>Value range in rpm: -12000^P to 3000^P to 12000^P</i>		√															
D40 ²⁾	Accel 4²⁾ : Acceleration time for ramp record 4 as related to 150 Hz. <i>Value range in sec/150 Hz * D98: 0 to 0.5 to 3000</i>		√															
D41 ²⁾	Decel 4²⁾ : Deceleration time for ramp record 4 as related to 150 Hz. <i>Value range in sec/150 Hz * D98: 0 to 0.5 to 3000</i>		√															
D42 ²⁾	Fix reference value 4²⁾ : See D12 . <i>Value range in rpm: -12000^P to 500^P to 12000^P</i>		√															
D50 ²⁾	Accel 5²⁾ : Acceleration time for ramp record 5 as related to 150 Hz. <i>Value range in sec/150 Hz * D98: 0 to 1 to 3000</i>		√															
D51 ²⁾	Decel 5²⁾ : Deceleration time for ramp record 5 as related to 150 Hz. <i>Value range in sec/150 Hz * D98: 0 to 1 to 3000</i>		√															
D52 ²⁾	Fix reference value 5²⁾ : See D12 . <i>Value range in rpm: -12000^P to 1000^P to 12000^P</i>		√															
D60 ²⁾	Accel 6²⁾ : Acceleration time for ramp record 6 as related to 150 Hz. <i>Value range in sec/150 Hz * D98: 0 to 2 to 3000</i>		√															
D61 ²⁾	Decel 6²⁾ : Deceleration time for ramp record 6 as related to 150 Hz. <i>Value range in sec/150 Hz * D98: 0 to 2 to 3000</i>		√															
D62 ²⁾	Fix reference value 6²⁾ : See D12 . <i>Value range in rpm: -12000^P to 2000^P to 12000^P</i>		√															
D70 ²⁾	Accel 7²⁾ : Acceleration time for ramp record 7 as related to 150 Hz. <i>Value range in sec/150 Hz * D98: 0 to 2.5 to 3000</i>		√															
D71 ²⁾	Decel 7²⁾ : Deceleration time for ramp record 7 as related to 150 Hz. <i>Value range in sec/150 Hz: 0 to 2.5 to 3000</i>		√															
D72 ²⁾	Fix reference value 7²⁾ : See D12 . <i>Value range in rpm: -12000^P to 2500^P to 12000^P</i>		√															
D80	Ramp shape: 0: linear; 1: 'S' ramp; Smoother acceleration/deceleration.		√															
D81	Decel-quick : Quick stop ramp. Effective if a binary input is programmed to quick stop (F3..=9) or parameter F38>0 . When a quick stop is triggered by the binary inputs, the drive is decelerated with the deceleration ramp set here. In position mode (C60=2), quick stop is performed on ramp I11 . <i>Value range in sec/150 Hz * D98: 0 to 0.2 to 3000</i>		√															
D90•	Reference value source : See block circuit diagram in chap. 19. 0: standard reference value; 1: motor potentiometer; Two binary inputs can be used to simulate a "motor potentiometer." This requires that one binary input be programmed to "4: motorpoti up" and another binary input to "5: motorpoti dwn" (e.g., F34=4 and F35=5). Only ramps D00 and D01 can change the speed. 2: motor potentiometer+reference value; The reference value for speed of the motor potentiometer function is added to the "standard" reference value (i.e., analog input, fixed reference values). When D90=1 , only the motor potentiometer reference value is used. The ramps selected with the binary inputs are used, and the motor potentiometer reference value changes with RV-accel/RV-decel (i.e., D00 and D01).	<table border="1"> <thead> <tr> <th>BE4</th> <th>BE5</th> <th>Motor Poti RV</th> </tr> </thead> <tbody> <tr> <td>L</td> <td>L</td> <td>Constant</td> </tr> <tr> <td>H</td> <td>L</td> <td>Larger</td> </tr> <tr> <td>L</td> <td>H</td> <td>Smaller</td> </tr> <tr> <td>H</td> <td>H</td> <td>0</td> </tr> </tbody> </table>	BE4	BE5	Motor Poti RV	L	L	Constant	H	L	Larger	L	H	Smaller	H	H	0	√
BE4	BE5	Motor Poti RV																
L	L	Constant																
H	L	Larger																
L	H	Smaller																
H	H	0																
D91	Motorpoti function : Only if D90≠0 (reference value source≠standard RV) 0: non-volatile; The reference value which was approached is retained both when the enable is removed and when the power is turned off/on. 1: volatile; The reference value is set to 0 when the enable becomes low or the power for the drive is turned off.		√															

^P Speed depends on pole number **B10**; $f_{max} = 400$ Hz. With a 4-pole motor, this is 12000 rpm at 400 Hz.
 • The power pack must be turned off before these parameters can be changed.
Italics These parameters are sometimes not shown depending on which parameters are set.
 1) See result table in chap. 15. 2) Only available when **D90≠1**
 Parameters which are included in the *normal* menu scope (**A10=0**). For other parameters, select **A10=1:extended** or **A10=2:service**.
E Parameters marked with a "√" can be parameterized separately from each other in parameter record 1 and 2.

13. Parameter Description

D.. Reference Value		Group D is not shown in run mode C60=2:position.	
Para. No.	Description		
D92	Negate reference value: See block circuit diagram in chap. 19. <i>0: inactive;</i> <i>1: active;</i> The reference value channel is negated. Corresponds to a reverse in direction of rotation. Not related to the selected reference value.		√
D93	RV-generator: For commissioning and optimizing the speed controller. <i>0: inactive;</i> Normal reference value selection. <i>1: active;</i> ± A51 is specified cyclically as reference value. The time can be set in D94 .		
D94	Ref. val. generator time: After this period of time, the sign of the reference value changes when D93=1:active. <i>Value range in msec:</i> 0 to 500 to 32767		√
D98	Ramp factor: If D98<0 and speed mode (C60=1), all ramps (e.g., D00) are shortened by one or two powers of ten. This makes very sensitive setting of short ramps possible. -2: *0.01 All ramp times shortened by factor of 100. -1: *0.1 All ramp times shortened by factor of 10. <i>0: *1</i> Factory setting. Ramps unchanged.		√

E.. Display Values		
Para. No.	Description	
E00	I-motor: Indicates the active motor current in amperes.	
E01	P-motor: Indicates the current power of the motor in kW and as a relative percentage in relation to nominal motor power.	
E02	M-motor: Indicates the current motor torque in Nm and as a relative percentage in relation to nominal motor torque.	
E03	DC-link-voltage: Indicates the current DC-link voltage. <i>Value range for single-phase inverters:</i> 0 to 500 V <i>Value range for three-phase inverters:</i> 0 to 800 V	
E04	V-motor: Indicates the current motor voltage. <i>Value range for single-phase inverters:</i> 0 to 230 V <i>Value range for three-phase inverters:</i> 0 to 480 V	
E05	f1-motor: Indicates the current motor frequency in Hz.	
E06	n-reference value: Only if C60=1 (speed). Indicates the current ref. val. for speed in relation to the motor shaft.	
E07	n-post-ramp: Only if C60=1 . Indicates the current speed in relation to the motor shaft after the ramp generator. Reflects the actual speed characteristic under consideration of the selected ramp. Cf. chap. 10.7.	
E08	n-motor: Indicates the current motor speed.	
E09	Rotor position: Only if B20=2:vect.feedback . Accumulates the increments of the motor encoder. With SSI encoders, the encoder position read from the encoder is entered during device startup. Digits in front of the decimal point indicate whole revolutions. The three positions after the decimal point are fractions of one motor revolution. This position is available in all run modes.	
E10	AE1-level: Level of the signal present on analog input (AE) 1 (X1.2 to X1.4). ±10 V is 100%.	
E11	AE2-level: Level of the signal present on analog input (AE) 2 (X1.A to X1.B). ±10 V is 100%.	
E12	ENA-BE1-BE2-level: Level of the enable inputs (X1.9), binary input 1 (X1.10) and binary input 2 (X1.11). Low level is represented by 0, and high level is represented by 1.	
E13	BE3-BE4-BE5-level: Level of binary inputs 3, 4 and 5 (X1.12 to X1.14). Low level is represented by 0, and high level is represented by 1.	
E14	BE5-frequence ref. value: If binary input 5 is parameterized to frequency reference value specification (F35=14), reference value output can be monitored here. 0% corresponds to a frequency specification of 100 Hz on BE5. 100% corresponds to the maximum permissible frequency reference value as entered under F37 .	
E15	n-encoder: If speed feedback is connected to BE4 and BE5 and BE5 is not parameterized to the frequency reference value, the actual encoder speed can be monitored here. The display is not related to the control mode set under B20 . When using the option board, remember B26=1 .	
E16	Analog-output1-level: Indicates the level on the analog output (X1.5 to X1.6). ±10 V corresponds to ±100%.	
E17	Relay 1: Status of relay 1 (ready for operation). <i>0: open;</i> For meaning, see parameter F10 . <i>1: closed;</i> Ready for operation.	
E18	Relay 2: Status of relay 2. The function of relay 2 is specified with parameter F00 . <i>0: open;</i> <i>1: closed;</i>	

^P Speed depends on pole number **B10**; $f_{max} = 400$ Hz. With a 4-pole motor, this is 12000 rpm at 400 Hz.

• The power pack must be turned off before these parameters can be changed.

Italics These parameters are sometimes not shown depending on which parameters are set.

1) See result table in chap. 15. 2) Only available when **D90≠1**

Parameters which are included in the *normal* menu scope (**A10=0**). For other parameters, select **A10=1:extended** or **A10=2:service**.

 Parameters marked with a "√" can be parameterized separately from each other in parameter record 1 and 2.

13. Parameter Description

E.. Display Values		E
<i>Para. No.</i>	<i>Description</i>	
E19	BE15...BE1 & enable: The status of the binary inputs including the option board is shown as a binary word.	
E20	Device utilization: Indicates the current load of the inverter in %. 100% corresponds to the nominal capacity of the inverter.	
E21	Motor utilization: Indicates the current load of the motor in %. Reference value is the nominal motor current specified under B12 .	
E22	i2t-device: Level of the thermal device model (i.e., i2t model). If utilization is 100%, the fault message "39:tempDev.i2t" appears. After being turned on, the inverter sets E22=80% .	
E23	i2t-motor: Level of the thermal motor model (i.e., i2t model). 100% corresponds to full utilization. The thermal model is based on the design data specified under group B (motor) (e.g., continuous operation (S1 operation)).	
E24	i2t-braking resistor: Level of the thermal braking resistor model (i.e., i2t model). 100% corresponds to full utilization. The data of the braking resistor are specified with A20 to A23 .	
E25	Device temperature: Current device temperature in °C. Is set to +25 °C when the FDS is powered with +24 V from an option board while the power supply (230 V or 400 V) is not present.	
E26	Binary output 1: Only present when an option board exists (E54=1 or 2).	
E27	BA15..1&Rel1: Status of all binary outputs as binary word. BA15 to BA1 are indicated from left to right. Relay 1 is indicated to the far right.	
E29	n-ref. value raw: Speed reference value before the offset ref. values and the reference value limitation. This is the master reference value for the winder and the free-wheeling reference value for synchronous running.	
E30	Run time: Indicates the current run time. Run time means that the inverter is connected to the power supply.	
E31	Enable time: Indicates the active time. Active time means that the motor is powered.	
E32	Energy counter: Indicates the total power consumption in kWh.	
E33	Vi-max-memorized value: The DC-link voltage is monitored continuously. The largest value measured is saved here in non-volatile memory. This value can be reset with A37→1 .	
E34	I-max-memorized value: The motor current is continuously monitored. The largest value measured is stored here in non-volatile memory. This value can be reset with A37→1 .	
E35	Tmin-memorized value: The temperature of the inverter is continuously monitored. The smallest value measured is stored here in non-volatile memory. This value can be reset with A37→1 .	
E36	Tmax-memorized value: The temperature of the inverter is continuously monitored. The greatest value measured is stored here in non-volatile memory. This value can be reset with A37→1 .	
E37	Pmin-memorized value: The active power of the drive is continuously monitored. The smallest value measured is stored here in non-volatile memory. This value can be reset with A37→1 .	
E38	Pmax-memorized value: The active power of the drive is continuously monitored. The largest value measured is stored here in non-volatile memory. This value can be reset with A37→1 .	
E40	Fault type: This parameter allows you to make a selection from archived faults. The inverter stores the last 10 faults in the order in which they occurred. The number of the fault is indicated at the top right. 1 indicates the latest fault, and 10 indicates the oldest fault. The type of fault is shown in plain text in the bottom line. Proceed as follows to select which of the 10 faults will be indicated. Press the [#] key. The number (1 to 10) of the indicated fault flashes in the top line. The type of fault is indicated in plain text in the bottom line (e.g., "31:short/ground"). The arrow keys can then be used to select the desired fault number.	
E41	Fault time: The run time at the time of the selected fault is indicated. Selection is the same as for E40 .	
E42	Fault count: Number of faults of the type of fault selected. Proceed as follows to select the type of fault. Press the [#] key. A fault code and the fault appear in plain text (e.g., "31:short/ground") in the bottom line. The arrow keys can then be used to select the desired type of fault. The number of faults of this event is shown in the top line (0 to 65,535).	
E45	Control word: Control of <i>Drivocom</i> device state machine during fieldbus operation with Kommubox.	
E46	Status word: Status of the device during fieldbus operation with Kommubox. See fieldbus documentation.	
E47	n-field-bus: Reference value speed during fieldbus operation with Kommubox.	
E50	Device: Indication of the exact device type (e.g., FDS 4024/B).	
E51	Software-version: Software version of the inverter (e.g., V4.5).	
E52	Device-number: Number of the device from a manufactured series. Same as the number on the nameplate.	
E53	Variant-number	

^P Speed depends on pole number **B10**; $f_{max} = 400$ Hz. With a 4-pole motor, this is 12000 rpm at 400 Hz.

- The power pack must be turned off before these parameters can be changed.

Italics These parameters are sometimes not shown depending on which parameters are set.

1) See result table in chap. 15. 2) Only available when **D90≠1**

Parameters which are included in the *normal* menu scope (**A10=0**). For other parameters, select **A10=1:extended** or **A10=2:service**.

E Parameters marked with a "√" can be parameterized separately from each other in parameter record 1 and 2.

13. Parameter Description

F.. Control Interface **E**

Para. No.	Description	
F00	<p>Relay2-function: Functions of relay 2 (X2.5 to X2.6). <i>0: inactive;</i> 1: brake; Used to control a brake. See F01, F02 and F06 and F07. See also chap. 8.6. 2: standstill; Output active (relay closes) when speed 0 rpm \pmC40 is reached. 3: reference value-reached; When C60=1 (speed mode): output is active when speed reference value is within \pmC40. When C60=2 (run "position" mode), <i>refVal-reached</i> means "in position." The signal appears when reference value specification is concluded (i.e., end of ramp) and the actual position is located within target window \pmI22. The signal is not withdrawn until the next start command. When enable-off occurs, "RefVal-reached" is reset when window I22 is exited or I21 (following error) is exceeded. "RefVal-reached" then remains low. This function cannot be used with process block changes via chaining "no stop" (J17=2). 4: torque-limit; Relay closes when the active torque limit is reached. See E62. 5: warning; Relay closes when a warning occurs. 6: operation range; Relay closes when the defined operational range (C41 to C46) is exited. 7: active parameter set; Only works when F00=7 is parameterized in both parameter records. Low signal (i.e., relay open) means that parameter record 1 is active. High signal (i.e., relay closed) means that parameter record 2 is active. The signal arrives <u>before</u> the new parameter record takes effect and can be used, for example, for contactor control for a two-motor drive. Cf. chap. 9.4. 8: electronic cam 1; Only applicable when C60=2 (run mode "position"). Signal appears when the actual position is located between the boundaries I60 and I61. Useful for starting actions on other drives or modules. 9: following error; Only applicable when C60=2. Maximum following error I21 was exceeded. The reaction to a following error (e.g., fault, warning, and so on) can be parameterized via FDS Tool. 10: posi.active; Only applicable when C60=2. Signal only appears when positioning control is in the basic status "17:posi.active" (i.e., no process block and no chaining being processed). This can be used to signal the end of a chaining sequence, for example. 11: PID-controller limit; Signals restriction of the output of the PID controller to the value G04. 12: synchron difference; Signals that the maximum synchronous angle difference G24 has been exceeded. 13: referenced; Only if C60=2 (position control). Output is high while the drive is being referenced (i.e., reference point traversing has been successfully concluded). 14: clockwise; Speed $n>0$. For zero crossing, hysteresis with C40. 15: fault; A fault has occurred. 16: inhibited; See run mode "12:inhibited" in chap. 16. 17: BE1; Route binary input to binary output. In addition to galvanic isolation, also used to read binary inputs via ASi bus. 18: BE2; Cf. selection "17:BE1." 19: Switch-memory 1; Output switch memory S1. Each of the "posi switching points" defined in Group N.. can be used to control 3 switch memories (S1, S2 and S3) simultaneously. 20: Switch-memory 2; Output switch memory S2. 21: Switch-memory 3; Output switch memory S3. 22: ready for reference value; The drive is powered. Magnetization is established. Reference value can be specified. 23: reference value-ackn.0; In position run mode: When no <i>posi.start</i>, <i>posi.step</i> or <i>posi.next</i> signal is queued, the <i>RV-select</i> signals are output inverted (monitoring with wire break detection). Otherwise active process block I82 is output. See time diagram in chap. 10.3. 24: reference value-ackn.1; See "23:reference value-ackn.0." 25: reference value-ackn.2; See "23:reference value-ackn.0." <i>26: inactive;</i> <i>27: inactive;</i> 28: BE3; Cf. selection "17:BE1." 29: BE4; 30: BE5; 31: BE6; 32: parameters active; Low signal means internal parameter conversions not completed. Useful for the handshake with a higher level controller when converting parameter records, and similar.</p>	√
F01	<p>Brake release: Only if F00=1 (brake) and B20\neq2 (control mode\neq vector-control with feedback), otherwise F06. If the reference value exceeds the set speed value, the brake releases (relay 2=closes). Value range in rpm: 0 to 300*</p>	√

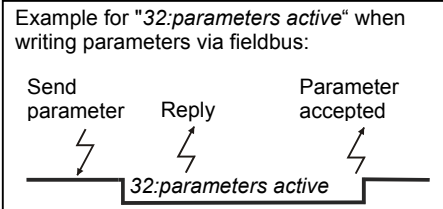

^P Depends on pole number **B10**; $f_{max} = 400$ Hz. With a 4-pole motor:, this is 12000 rpm at 400 Hz.
 • The power pack must be turned off before these parameters can be changed.
Italics These parameters are sometimes not shown depending on which parameters are set.
 1) See result table in chap. 15. 2) Only available if **D90 \neq 1**
 Parameters which are included in the *normal* menu scope (**A10=0**). For other parameters, select **A10=1:extended** or **A10=2:service**.
E Parameters marked with a "√" can be parameterized separately from each other in parameter record 1 and 2.

13. Parameter Description

F.. Control Interface		E
<i>Para. No.</i>	<i>Description</i>	
F02	Brake set: Only if F00 =1 (brake) and B20 ≠2 (control mode≠ vector-control with feedback), otherwise F07 . When the drive is halted to a standstill by a "halt" or a "quick stop" command, the brake is applied when the set speed value is passed below (relay 2=opens). <i>Value range in rpm: 0 to 300*</i>	√
F03	Relay 2 t-on: Only if F00 >0. Causes a delay in switch-on of relay 2. Can be combined with all functions of relay 2. The related function must be present for at least t-on so that the relay switches. <i>Value range in sec: 0 to 5.024</i>	√
F04	Relay 2 t-off: Only if F00 >0. Causes a delay in switch-off of relay 2. Can be combined with all functions of relay 2. <i>Value range in sec: 0 to 5.024</i>	√
F05	Relay 2 invert: Only if F00 >0. Permits the relay-2 signal to be inverted. Inversion occurs after the function switch-on/switch-off delay (F04/F03). Can be combined with all functions of relay 2. <i>Value range: 0 to 1</i>	√
F06	t-brake release: Only if F00 =1 (brake) and B20 =2 (vector-control with feedback). Defines the amount of time the brake is released. F06 must be selected approximately 30 msec greater than the time t_1 in section M of the STÖBER MGS catalog. When the enable is granted or the halt/quick stop signal is removed, startup is delayed by the time F06 . See also B25 . <i>Value range in sec: 0 to 5.024</i>	√
F07	t-brake set: Only if F00 =1 (brake) and B20 =2 (vector-control with feedback). Defines the time the brake is applied. F07 must be selected approximately 30 msec greater than the time t_1 (MGS catalog). When the enable and halt/quick stop is removed, the drive still remains under control for the time F07 . Time $t_1 \Rightarrow$ scanning time t_{21} Δ t₂₁ varies with switching on AC or DC side! Δ <i>Value range in sec: 0 to 5.024</i>	√
F10	Relay 1-function: Relay 1 is closed when the inverter is ready for operation. The opening of the relay can be controlled by scanning the status of relay 1 via parameter E17 . 0: fault; Relay is open when a fault occurs. 1: fault and warning; Relay open when a fault or warning occurs. 2: fault and warning and message; Relay open when a fault, warning or message occurs. If auto-reset (A32 =1) is active, the switching of the relay is suppressed until all auto-acknowledgment attempts have been exhausted.	√
F19	Quick stop end: Only if C60 =1. F19 is available starting with SV 4.5E. It specifies when the quick stop ramp can be concluded. 0: Standstill; With the rising edge of the quick stop signal (or removal of the enable for F38 >0), the drive brakes down to standstill ("zero reached" message) even when the quick stop signal (or enable off) was only briefly queued. 1: No stop; When the quick stop signal disappears or the enable returns, the drive immediately accelerates again to the current reference value.	√
F20•	AE2-function: Function of analog input 2 (X1.A to X1.B). Caution: F20 ≠ F25 must be true. 0: inactive; 1: additional reference value; Additional reference value input. Takes effect regardless of which operation input is selected. Is added to the running reference value (A30). 100% control of AE2 is 100 Hz (3000 rpm for 4-pole motor). Can be scaled with F21 and F22 . 2: torque-limit; Additional torque limit. 10 V=nominal motor torque. Active torque limit is the minimum from M-Max 1 (C03), M-Max 2 (C04) and the level on analog input 2. 3: power-limit; External power limit whereby 10 V=nominal motor power. 4: reference value-factor; The main reference value on AE1 is multiplied by the RV-factor (10 V=100%). Also applicable to relative movements in run mode C60 =2:Position. 5: override; In positioning mode (C60 =2), the current positioning speed is changed via AE2 during traversing. 0 V=standstill! 10 V=programmed speed if F22 =100%. During synchronous running (G20 >0), the speed ratio is changed via override. 6: posi.offset; Only effective in positioning mode (C60 =2). An offset based on the voltage on AE2 is overlaid on the current reference value position. The ratio of path/voltage is specified with I70 . 7: winding diameter; Only effective if G10 =1 (winding operation active). 8: rotation field magnet moment; Torque control for rotation field magnets. V/f-control (B20 =0) is used. The speed is set to the nominal value via the fixed reference value, for example. F20 =8 can be used to affect the motor voltage via AE2. Since torque corresponds to the square of the motor voltage, this voltage is weighted with the <u>root</u> of the AE2 signal. 9: n-Max; Limitation of the maximum speed via external voltage.	√

^P Depends on pole number **B10**; $f_{max} = 400$ Hz. With a 4-pole motor:, this is 12000 rpm at 400 Hz.

• The power pack must be turned off before these parameters can be changed.

Italics These parameters are sometimes not shown depending on which parameters are set.

1) See result table in chap. 15.

2) Only available if **D90**≠1

Parameters which are included in the *normal* menu scope (**A10**=0). For other parameters, select **A10**=1:extended or **A10**=2:service.

E Parameters marked with a "√" can be parameterized separately from each other in parameter record 1 and 2.

13. Parameter Description

F.. Control Interface		E
<i>Para. No.</i>	<i>Description</i>	
F20• <i>Continuation</i>	<p>10: reference value; Ref. value for speed or torque (AE1 is typically parameterized to "10:reference value").</p> <p>11: PID-reference; Second input of the PID controller. This can be used to generate the standard deviation from two analog inputs. Cf. block circuit diagram in chap. 11.1.</p> <p>12: winder roller; Only effective for winder software (G10>0) when the diameter is calculated by integration of the roller deviation (G11=2).</p> <p>13: synchron offset; Only effective for synchronous running (G20>0). The current slave position is overlaid with an angle offset corresponding to the voltage on the analog input. The angle/voltage ratio is specified in G38. Cf. block circuit diagram in chap. 18.</p> <p>14: synchron reference value; Speed precontrol during angle synchronous running (G20>0) via external analog voltage. The slave can be supplied with the same speed reference value as the master. This minimizes dynamic angle deviation. Cf. block circuit diagram in chap. 18.</p>	
F21	<p>AE2-offset: An offset on analog input 2 (X1.A to X1.B) can be corrected. To do this, jumper terminals X1.A and X1.B. Then observe the AE2 level in parameter E11, and enter it with the reverse sign in parameter F21. For example, if parameter E11 indicates 1.3%, F21 must be parameterized to -1.3%. The value range is ±100%. <i>Value range in %:</i> -100 to 0 to 100</p>	√
F22	<p>AE2-gain: The signal present on analog input 2 is added to the AE2 offset (F21) and then multiplied by this factor. Depending on F20, F22 is scaled as shown below.</p> <p>F20= 1 ⇒ 10 V = F22 x 100 Hz (3000 rpm)*</p> <p>F20= 2 ⇒ 10 V = F22 x nominal motor torque</p> <p>F20= 3 ⇒ 10 V = F22 x nominal motor power</p> <p>F20= 4 ⇒ 10 V = F22 x multiplication with 1.0</p> <p>F20= 5 ⇒ 10 V = F22 x programmed positioning speed</p> <p>F20= 6 ⇒ 10 V = F22 x path in I70</p> <p>F20= 7 ⇒ 10 V = F22 x (D-Max – D-Min). See chapter 11.2.1.</p> <p>F20= 8 ⇒ 10 V = F22 x nominal motor voltage</p> <p>F20= 9 ⇒ 10 V = F22 x 100 Hz (3000 rpm)*</p> <p>F20=10 ⇒ 10 V = F22 x 100% input of ref. val. curve</p> <p>F20=11 ⇒ 10 V = F22 x 100%</p> <p>F20=12 ⇒ 10 V = F22 x 100% for G11=2</p> <p>F20=13 ⇒ 10 V = F22 x G38</p> <p>F20=14 ⇒ 10 V = F22 x 100 Hz (3000 rpm)*</p> <p>Example: If F20=1 and F22=50%, the offset is 1500 rpm with 10 V and AE2. Note: The gain of the PID controller (G00=1) is multiplied by F22. <i>Value range in %:</i> -400 to 100 to 400</p> <div style="border: 1px solid black; padding: 5px; margin-top: 10px;"> <p>* With 4-pole motor: 100 Hz is 3000 rpm. With other motors: Speed must be converted.</p> <p>B10=2 → 100 Hz = 6000 rpm B10=6 → 100 Hz = 2000 rpm</p> </div>	√
F23	<p>AE2-lowpass: Smoothing time constant. Useful for setting up control loops via AE2 (with or without a PID controller) to avoid high-frequency oscillation. Caution: High time constants will make the control loop unstable. <i>Value range in msec:</i> 0 to 10000</p>	√
F24	<p>AE2-offset2: An additional offset after multiplication by F22. Used when the reference value is to be multiplied between 95% and 105% via AE2, for example. <i>Value range in %:</i> -400 to 0 to 400</p>	√
F25	<p>AE1-function: See F20 AE2 function. Caution: Parameters F25 and F20 may not be equal! F25≠F20. <i>Value range:</i> 0 to 10 to 14</p>	√
F26	<p>AE1-offset: Cf. F21. <i>Value range in %:</i> -400 to 0 to 400</p>	√
F27	<p>AE1-gain: Cf. F22. <i>Value range in %:</i> -400 to 100 to 400</p>	√
F30	<p>BE-logic: Logical link when several BEs are programmed for the same function. <i>0:</i> OR; <i>1:</i> AND;</p>	√
F31•	<p>BE1-function: All binary inputs can be programmed as desired. Selection points 0 to 13 and those greater than 16 are identical for all binary inputs. If the same function is used by several BEs, F30 can be used to program a logical link. Inversion can be performed with F51 to F55 and F70 to F74. <i>0:</i> inactive; 1: reference value-select 0; Binary coded selection of fixed reference values or process blocks. The result of the reference value selection is indicated in E60. 2: reference value-select 1; See above.</p>	√

^P Depends on pole number **B10**; $f_{max} = 400$ Hz. With a 4-pole motor:, this is 12000 rpm at 400 Hz.

• The power pack must be turned off before these parameters can be changed.

Italics These parameters are sometimes not shown depending on which parameters are set.

1) See result table in chap. 15.

2) Only available if **D90**≠1

Parameters which are included in the *normal* menu scope (**A10**=0). For other parameters, select **A10**=1:extended or **A10**=2:service.

E Parameters marked with a "√" can be parameterized separately from each other in parameter record 1 and 2.

13. Parameter Description

F.. Control Interface

Para. No.	Description															
F31• Continuation	<p>3: reference value-select 2; See above.</p> <p>4: motorpoti up; If D90=1, two binary inputs can be used to simulate a motor potentiometer. One BE must be programmed as "4:Motorpoti up," and another BE must be programmed as "5:Motorpoti dwn." See also D90.</p> <p>5: motorpoti down; Same as "4:Motorpoti up."</p> <p>6: direction of rotation; Negation of the current reference value.</p> <p>7: additional enable; BE provides the function of an additional enable (i.e., a fault can also be acknowledged via this additional enable). The drive is not enabled unless a high signal is present on the "enable" input (X1.9) and the binary input.</p> <p>8: halt; With high signal, drive is slowed with the selected deceleration ramp. If F00=1, the brake is then applied. <u>Ramps:</u> Analog RV specification/motor potentiometer: D01; fixed reference values: D12 to D72; Positioning: process block ramp.</p> <p>9: quick stop; When a rising edge occurs, the drive is slowed with the selected decel-quick ramp (D81). The brake is then applied if F00=1. A brief high pulse (≥ 4 msec) on the binary input is sufficient to trigger the quick stop. A drop in quick stop is impossible until speed C40 is passed below. Cf. also F38. Caution: Torque limit C04 is always active for quick stop.</p> <p>10: torque select; Switches between the torque limits M-Max 1 (C03) and M-Max 2 (C04). Low signal=M-Max 1. High signal = M-Max 2.</p> <p>11: parameter set-select; A parameter record can only be selected via BE if A41=0. This means that this binary input must be set to 11 in both parameter records. A low signal means that parameter record 1 is selected. A high signal means that parameter record 2 is selected. The selected parameter record does not become active until the enable is removed. Cf. chap. 9.4.</p> <p>12: extern fault; Permits fault messages of the periphery to be evaluated. The inverter evaluates a rising edge on the binary input and assumes "44:ext.fault." If several binary inputs are programmed for external fault, the rising edge can only be evaluated when a low signal is present on the other binary inputs programmed for "12:ext.fault."</p> <p>13: fault reset; A fault which is no longer queued can be acknowledged with a rising edge. If several binary inputs are programmed for acknowledgment, the rising edge can only be evaluated when a low signal is present on the other binary inputs programmed with "13:faultReset."</p> <p>14: counter-clockwise V3.2; By programming F31=14 and F32=14, the direction of rotation specification can be simulated by inverters with the V3.2 software. In this case, the functions "direction of rotation," "halt," and "quick stop" may not be assigned to other binary inputs.</p> <table border="1"> <thead> <tr> <th>BE1</th> <th>BE2</th> <th>Command</th> </tr> </thead> <tbody> <tr> <td>0</td> <td>0</td> <td>Quick stop (if F38≠0) or halt (F38=0)</td> </tr> <tr> <td>0</td> <td>1</td> <td>Clockwise rotation</td> </tr> <tr> <td>1</td> <td>0</td> <td>Counterclockwise rotation</td> </tr> <tr> <td>1</td> <td>1</td> <td>Halt</td> </tr> </tbody> </table> <p>15: inactive;</p> <p>16: posi.step; 1 pulse ($t \geq 4$ msec) starts the movement without interrupting the positioning procedure in progress. Primarily used for manual next-block procedures with process-block chaining. Cf. J17=0 and J01.</p> <p>17: tip +; Manual traversing in the positive direction (tipping). HALT (selection 8) must be active. For manual speed with <i>posi</i>, see I12. When synchronous running is active (G20>0), TIP+ or TIP- is used to add the current speed RV to the movement of the slave (angle offset). Otherwise no meaning in speed run mode. In speed operating mode (C60=1), the operational state "22:tip" appears on Controlbox and the motor stops as called for in "8:halt" ($n=0$).</p> <p>18: tip -; Manual traversing in the negative direction.</p> <p>19: posi.start; 1 pulse ($t \geq 4$ msec) starts the movement. Terminates any positioning procedure in progress, and proceeds to the new destination (i.e., changing destination on the fly). Process block selection via BEs (RV-select) or J02.</p> <p>20: posi.next; (With chained process blocks) 1 pulse ($t \geq 4$ msec) interrupts the running process block and starts the next one. <i>Important:</i> A braking path can be defined there, for example. Evaluation of <i>posi.next</i> must be programmed specifically to the process blocks. Cf. J17=3:posi.next. Otherwise the drive will not react to <i>posi.next</i>! If <i>posi.next</i> is parameterized to BE3, the signal is recorded without a time delay (i.e., high repetition accuracy).</p> <p>21: stop +; Limit switch at the positive end of the traversing area. In position mode, the limit switch causes a fault.</p> <p>22: stop -; Limit switch at the negative end of the traversing area. In speed mode, the dir. of rotation is disabled.</p> <p>23: reference input; Input for reference switch (I30=0).</p> <p>24: start reference; Change in edge from low to high starts reference point traversing. See also I37=0.</p> <p>25: teach-in; With a rising edge, the target position of the currently selected process block is overwritten with the present actual position and stored in non-volatile memory. See also J04.</p>	BE1	BE2	Command	0	0	Quick stop (if F38 ≠0) or halt (F38=0)	0	1	Clockwise rotation	1	0	Counterclockwise rotation	1	1	Halt
BE1	BE2	Command														
0	0	Quick stop (if F38 ≠0) or halt (F38=0)														
0	1	Clockwise rotation														
1	0	Counterclockwise rotation														
1	1	Halt														

P Depends on pole number **B10**; $f_{max} = 400$ Hz. With a 4-pole motor:, this is 12000 rpm at 400 Hz.

• The power pack must be turned off before these parameters can be changed.

Italics These parameters are sometimes not shown depending on which parameters are set.

1) See result table in chap. 15. 2) Only available if **D90**≠1

Parameters which are included in the *normal* menu scope (**A10=0**). For other parameters, select **A10=1:extended** or **A10=2:service**.

Parameters marked with a "√" can be parameterized separately from each other in parameter record 1 and 2.

13. Parameter Description

F.. Control Interface		E
Para. No.	Description	
F31• Continuation	<p>26: disable PID-controller; PID controller on AE2 is disabled and the integrator is reset. Cf. chap. 11.1.</p> <p>27: synchron free-run; The reference value for synchronous running is disconnected. The drive can be moved as desired via analog input AE1, for example. Speed adjustment is performed on the current reference value ramp (e.g., D00).</p> <p>28: synchron reset; The angle deviation of synchronous-run control is reset. Cf. chap. 18.</p> <p>29: set initial winding diameter;</p> <p>30: to 31: inactive;</p> <p>32: brake release; Manual brake control via a BE (higher priority than the internal brake function).</p>	
F32•	<p>BE2-function: 0 to 13 and starting with 15, see F31. <i>14:clockwise V3.2;</i> Value range: 0 to 6 to 32</p>	√
F33•	<p>BE3-function: 0 to 13 and starting with 15, see F31. The "20:posi.next" and "23:reference input" signals are acquired immediately on BE3 during continuing reference point traversing.</p> <p>14: encoderSignal 0; Only if B20=2 (vector-control with feedback). The "zero signal" (= track "C," one pulse per rotation) of the incremental encoder. This signal is used for reference point traversing in position mode and is not a requirement for the "vector-control with feedback" function.</p> <p>Value range: 0 to 1 to 32</p>	√
F34•	<p>BE4-function: 0 to 13 and starting with 15, see F31.</p> <p>14: encoderSignal A; Only if B20=2 (vector-control with feedback). The "A signal" of the incremental encoder.</p> <p>Value range: 0 to 2 to 32</p>	√
F35•	<p>BE5-function: 0 to 13 and starting with 16, see F31.</p> <p>14: frequency-RV; The inverter is parameterized to the frequency reference value specification. Analog input 1 (X1.2 to 4) is ignored. The maximum frequency entered under F37 corresponds to a reference value output of 100%. Frequencies under 1 Hz are interpreted as 0% output. The frequency RV is further processed internally with the reference value characteristic (D02 to D05) and the ramp generator (D00/D01). Instead of "frequency reference value," the synchronous running function (G20>0) can also be used together with specification of frequency + sign (chap. 12).</p> <p>15: encoderSignal B; Only if B20=2 (vector control with feedback). This is the "B signal" of the incremental encoder. This signal is a mandatory requirement for the function "vector control with feedback."</p> <p>Value range: 0 to 32</p>	√
F36•	<p>BE-increments: When an incremental encoder is used on BE4 and BE5, the number of increments per revolution must be entered here. If the incremental encoder is not mounted on the motor shaft, the step-down ratios may have to be considered. When external encoders (i.e., not on the motor) are used, remember F49.</p> <p>Value range in I/R: 30 to 1024 to 4096</p>	√
F37•	<p>Fmax frequency-ref. value: Only if binary input 5 is parameterized to frequency reference value (F35=14). Maximum permissible frequency. Frequency F37 corresponds to a reference value output of 100%. The fixed minimum frequency of 100 Hz corresponds to a reference value output of 0%.</p> <p>Value range in kHz: 3 to 51.2</p>	√
F38	<p>Quick stop: Only if C60≠2 (run mode≠position). F38 controls the automatic triggering of quick stop under certain operating conditions (brake on quick stop ramp D81).</p> <p>0: inactive; Quick stop can only be triggered by the BE function "9:Quick stop."</p> <p>1: enable and clockwise/counter-clockwise; Important for use of two direction-of-rotation inputs (i.e., clockwise and counterclockwise) on BE1 and BE2. Quick stop is triggered when BE1 is low and BE2 is low or when the enable is removed (also reference value enable D07 or additional enable via BE).</p> <p>2: fault and enable; In addition to the BE function "9:Quick stop," removal of the enable and "non-dangerous" faults (e.g., "46:Low voltage") causes the quick stop.</p> <p>During positioning (C60=2), quick stop is always triggered with F38=2.</p>	√
F40	<p>Analog-output1-function: Functions of analog output X1.5 - X1.6. A voltage of ±10 V is available on the terminals. The resolution is 19.5 mV, and the scanning time is 4 msec.</p> <p>0: inactive;</p> <p>1: E00 I-motor; Indication of motor vector current, 10 V=nominal inverter current, unipolar.</p> <p>2: E01 P-motor; Indication of motor active power, 10 V=nominal motor power (B11), bipolar.</p> <p>3: E02 M-motor; Indication of motor torque, 10 V=nominal motor torque, bipolar.</p> <p>4: E08 n-motor; Indication of motor speed, 10 V=n-max (C01), bipolar.</p> <p>5: G19 D-actual.; Indication of the diameter (winder), 10 V=Dmax (G13).</p> <p>6: winder actual tension; Output of current winder tension. F-tension=(M-act./M0 x (D-max/D-act.) 100%.</p> <p>7: +10V; Fixed value (e.g., for powering a potentiometer).</p> <p>8: -10V; Fixed value (e.g., for powering a potentiometer).</p> <p>9: winder tension setpoint; Tension reference value for winding at torque limit (G10=2).</p> <p>10: motor potent. value; 10 V = n-Max (C01), unipolar.</p> <p>11: E07 n-post-ramp; 10 V = n-Max (C01), bipolar.</p>	√

^P Depends on pole number **B10**; $f_{max} = 400$ Hz. With a 4-pole motor., this is 12000 rpm at 400 Hz.

• The power pack must be turned off before these parameters can be changed.

Italics These parameters are sometimes not shown depending on which parameters are set.

1) See result table in chap. 15. 2) Only available if **D90≠1**

Parameters which are included in the *normal* menu scope (**A10=0**). For other parameters, select **A10=1:extended** or **A10=2:service**.

E Parameters marked with a "√" can be parameterized separately from each other in parameter record 1 and 2.

13. Parameter Description

F.. Control Interface		E
<i>Para. No.</i>	<i>Description</i>	
F41	Analog-output1-offset: Offset of analog output X1.5 - X1.6. <i>Value range in %:</i> -400 to 0 to 400	√
F42	Analog-output1-gain: The raw value specified via F40 is offset with F41 and multiplied by factor F42 . Example: If F40 =1 and F42 =50%, then 5 V on the analog output=nominal inverter current. <i>Value range in %:</i> -400 to 100 to 400	√
F43	Analog-output1-absolute: An absolute value (amount) is generated for the output signal. <i>0:</i> inactive; <i>1:</i> active;	√
F49	BE-gear ratio: Only if C60 =2. Conversion of an external posi encoder to the motor shaft. Caution: Parameter has no effect on the speed calculation for motor control (vector control). It is only used to convert the position of an external encoder. The following must apply: F49 = number of motor revolutions/number of encoder revolutions. If this formula results in values over 32.767, the number of encoder increments in F36 must be divided by a suitable factor (e.g., 2). The result of the above formula is then also divided and entered in F49 . See also chapters 10.11.2. <i>Value range:</i> 0 to 1 to 32.767	√
F51 to F55•	BE1-invert to BE5-invert <i>0:</i> inactive; No inversion. <i>1:</i> active; Input is inverted. Useful for the HALT signal or limit switch, for example.	√
F60•	BE6-function: Additional inputs only available with option boards. Selection via F31 : BE1 function (exception: F60 =14:inactive). <i>Value range:</i> 0 to 32	√
F61•	BE7-function: See F60 . <i>Value range:</i> 0 to 32	√
F62•	BE8-function: See F60 . <i>Value range:</i> 0 to 32	√
F63•	BE9-function: See F60 . <i>Value range:</i> 0 to 32	√
F64•	BE10-function. See F60 . <i>Value range:</i> 0 to 32	√
F65•	BE11-function: See F60 . BE11 to BE14 are only available with option board ASI-4000. <i>Value range:</i> 0 to 32	√
F66•	BE12-function: See F60 . <i>Value range:</i> 0 to 32	√
F67•	BE13-function: See F60 . <i>Value range:</i> 0 to 32	√
F68•	BE14-function: See F60 . <i>Value range:</i> 0 to 32	√
F70... F74•	BE6-invert to BE10-invert: Cf. F51 to F55 (only available with option boards). <i>0:</i> inactive; no inversion. <i>1:</i> active; Input is inverted.	√
F80	BA1-function: Function of binary output 1 on an option board <i>1:</i> inactive; <i>2 to 32:</i> Selection values in acc. w. parameter F00 (relay2-function).	√
F81	Relay2-function: Selection values in acc. w. parameter F00 . <i>Value range:</i> 0 to 32	√
F82	BA3-function: Selection values in acc. w. parameter F00 . Only available with option boards. <i>Value range:</i> 1 to 32	√
F83	BA4-function: Selection values in acc. w. parameter F00 . <i>Value range:</i> 1 to 32	√
F84	BA5-function: Selection values in acc. w. parameter F00 . <i>Value range:</i> 1 to 32	√
G.. Technology		E
<i>Para. No.</i>	<i>Description</i>	
G00•	PID-controller: Activates the PID controller on input AE2. Cf. chapter 11.1. <i>0:</i> inactive; <i>1:</i> active;	√

^P Depends on pole number **B10**; $f_{max} = 400$ Hz. With a 4-pole motor:, this is 12000 rpm at 400 Hz.

• The power pack must be turned off before these parameters can be changed.

Italics These parameters are sometimes not shown depending on which parameters are set.

1) See result table in chap. 15. 2) Only available if **D90**≠1

Parameters which are included in the *normal* menu scope (**A10**=0). For other parameters, select **A10**=1:extended or **A10**=2:service.

E Parameters marked with a "√" can be parameterized separately from each other in parameter record 1 and 2.

13. Parameter Description

G.. Technology		E
Para. No.	Description	
G01	PID-controller Kp: Only if G00=1 (i.e., PID controller active). Loop gain. The total gain of the control loop is also affected by F22 (AE2 gain) in addition to G01 . Cf. block circuit diagram in chap. 11.1. <i>Value range:</i> 0 to <u>0.3</u> to 100	√
G02	PID-controller Ki: Only if G00=1 (i.e., PID controller active). Gain of I in 1/sec. Example: If G02=0.2 x 1/sec, then a 20% higher constant input signal is integrated within one second. <i>Value range in 1/sec:</i> 0 to 10	√
G03	PID-controller Kd: Only if G00=1 (i.e., PID controller active). Gain of D in msec. <i>Value range in msec:</i> 0 to 1000	√
G04	PID-controller limit: Only if G00=1 (i.e., PID controller active). Adjuster-variable limit. For scaling, see F22 . Asymmetric limits can be specified with G04 and G05 (e.g., from -10% to +30%). Upper and lower limit values are automatically (internally) sorted correctly. <i>Value range in %:</i> -400 to <u>400</u>	√
G05	PID-controller limit2: See G04 . <i>Value range in %:</i> -400 to 400	√
G06	PID-controller Kp2: Pure proportional gain of the PID controller. Effective parallel to I and D portion. <i>Value range:</i> 0 to <u>1</u> to 10	√
G10•	Winding operation: Activates the winding functions (speed reduction based on diameter). <i>0:</i> inactive; <i>1:</i> n mode; Speed adjustment in accordance with $n \sim 1/D$. No effect on torque limit M-Max. <i>2:</i> M-Max mode; Maximum torque is reduced based on D_{Act}/D_{Max} .	√
G11	Diameter: Only if G10≠0 (winding operation active). Specifies the type of diameter definition. <i>0:</i> AE-measurement; Diameter sensor 0 to 10 V is connected to AE2. <i>1:</i> n-line/n-motor; For traction or compensating roller controllers. The diameter is calculated from the ratio of control speed and motor speed. The control speed (i.e., speed reference value) always refers to an empty reel (i.e., the smallest diameter). <i>2:</i> roller; The diameter is calculated with an overtravel ramp based on E122 (from fieldbus or via analog input function "12:winder roller"). If E122 > 5%, G19 is increased by ramp G16 . If E122 < -5%, G19 is decreased by ramp G16 . Otherwise G19 remains constant.	√
G12	Min. winding diameter: Only if G10≠0 (winding operation active). Diameter of an empty reel. <i>Value range in mm:</i> <u>10</u> to 3000	√
G13	Max. winding diameter: Only if G10≠0 (winding operation active). Diameter of a full reel. <i>Value range in mm:</i> 10 to 100 to 3000	√
G14	Begin. winding diameter: Only if G10≠0 (winding operation active). Initial diameter. Must be set via a binary input with the function "29:wind.setD-ini" (F31 to F35). <i>Value range in mm:</i> <u>10</u> to 3000	√
G15	Overdrive ref. value: Only if G10≠0 (winding operation active). G15 is added to the control reference value while winding at the torque limit (G10=2) so that M-limit is triggered and the winding material remains taut. <i>Value range in rpm:</i> -12000 ^P to 0 to 12000 ^P	√
G16	Diam.calculator ramp: Only when G10>0 . Integration speed of the diameter calculation. G11=0: no function G11=1: limitation of the integration speed for G19 G11=2: ramp with which the diameter is changed when $-5\% < E122 < +5\%$. <i>Value range in mm/sec:</i> 0 to <u>10</u> to 100	√
G17	Tension reduction: Only when G10>0 . Reduction of tension as diameter increases. When min. diameter D-Min, winding with 100% tension. Up to D-Max: tension reduced linearly up to $(100\% - G17)$. <i>Value range in %:</i> <u>0</u> to 100	√
G19	Actual. winding diameter: Only if G10≠0 (winding operation active). Indication of the current diameter.	
G20•	Electronic gear: Only when C60=1: speed . Activates the "electronic gear/synchronous running" function (chap. 12). See block circuit diagram in chap. 18. <i>0:</i> inactive; <i>1:</i> speed synchron run; G24 limits the effect of the angle controller. Cf. chap. 12.6. <i>2:</i> angle synchron run <i>3:</i> angle + save; Same as G20=2 . Exception: The angle of deviation is stored non-volatily 100 msec after each enable-off. It is then also available after power off/on. See also G25 .	√

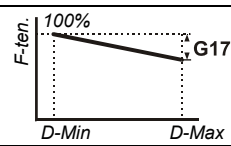

^P Depends on pole number **B10**; $f_{max} = 400$ Hz. With a 4-pole motor, this is 12000 rpm at 400 Hz.

• The power pack must be turned off before these parameters can be changed.

Italics These parameters are sometimes not shown depending on which parameters are set.

1) See result table in chap. 15.

2) Only available if **D90≠1**

Parameters which are included in the *normal* menu scope (**A10=0**). For other parameters, select **A10=1:extended** or **A10=2:service**.

E Parameters marked with a "√" can be parameterized separately from each other in parameter record 1 and 2.

13. Parameter Description

G.. Technology		E
<i>Para. No.</i>	<i>Description</i>	
G21	Speed master: Only if G20 >0 (electronic gear active). The slave speed is calculated from $nSlave = G22/G21 \times nMaster$. The increments of the incremental encoders are specified with F36 and H22 . If G21 =1 and G22 =2, the slave is twice as fast as the master. We recommend keeping increments F36 and H22 the same or selecting both as powers of 2 (e.g., 512 and 1024). Otherwise, the number range of G21 and G22 is reduced based on $G21 \times inc_master \times 4 < 2^{31}$ and $G22 \times inc_slave \times 4 < 2^{31}$. <i>Value range:</i> 1 to 2147483647	√
G22	Speed slave: Only if G20 >0 (electronic gear active). See G21 . At a speed ratio of 1:1, G21 = G22 =1 must be parameterized. The direction of rotation can be changed with D92 . <i>Value range:</i> 1 to 2147483647	√
G23	Kp synchron: Only if G20 >0 (electronic gear active). Gain of the angle controller in 1/sec. Typical values are 10 to 60. G23 =0 activates speed synchronous running. The slave then no longer attempts to catch up with the master (e.g., after a blockage). Instead, the mathematically precise speed ratio is only ensured within the window $\pm G24$. When G23 =0 and G24 =0, the master encoder is only used as a speed reference value, and the ratio set in G22/G21 is not precisely maintained mathematically. Cf. chapter 12.5. <i>Value range in 1/sec:</i> 0 to 30 to 100	√
G24	Max. synchron. difference: Only if G20 >0 (electronic gear active). Maximum angle of deviation between master and slave (following error). When this value is exceeded, a signal is generated on the output (cf. F00 or F80 =12:synch.diff.), but no fault is triggered. This can be performed with external wiring and the input function "12:ext.fault" (F31 to F35). <i>Value range in °:</i> 0 to 3600 to 30000	√
G25	Synchron reset: Only if G20 >0. Defines conditions for resetting the current synchronous deviation. 0: with BE ; Reset only possible with BE function "28:SyncReset" (always possible). 1: enable & BE ; Reset also with removal of the enable as well as with halt and quick stop. 2: free run & BE ; Reset only with BE functions "27:syncFreeRun" and "28:SyncReset." 3: enable & free run & BE ; All methods above will cause a reset. The synchronous deviation is always set to zero when the device is turned on. (Exception: G20 =3. Reset is only performed when the stored deviation exceeds 15°).	√
G26	n-correction-Max: Only if G20 >0 (electronic gear active). G26 limits the output of the angle controller. Important when large angle deviations must be reduced (e.g., when the free-run function is used). <i>Value range in rpm:</i> 0 to 3000 ^P to 12000 ^P	√
G27	Synchronous encoder: Only if G20 > 0. Signals of the master arrive over this interface. 0: BE -encoder; Master signals are connected to binary inputs. 1: X20 ; Master signals arrive over plug connector X20 .	√
G28	n-Master: Only if G20 >0. For monitoring during commissioning. Speed of synchronous encoder as per G27 . <i>Value range in rpm:</i> $\pm 12000^P$	
G29	Synchron difference: Only if G20 >0 (electronic gear active). Indication of the current synchronous deviation in degrees as related to the slave motor. n-controller Ki >0 is required for a synchronous deviation near 0.	
G30	Speed feed forward: Speed precontrol for synchronous running. When G30 =100%, no following error is used when speed is constant (synchronous deviation is zero). With dynamic movements, G30 must be reduced (50 to 80%). Otherwise the slave will overswing. <i>Value range in %:</i> 0 to 80 to 100	√
G31	Reference direction: Only if G20 >0. Starting direction to look for the reference point. Referencing searches for a reference cam. Cf. I30 =0:Ref.input in positioning mode and the examples in chap. 10.6. Synchronous deviation is reset at the reference position. Other ways of resetting the synchronous deviation include the BE signal "28:Synchron Reset" or automatically with parameter G25 . 0: positive; 1: negative;	√
G32	Reference speed fast: Only if G20 >0. Speed for first phase of referencing (rough traversing). <i>Value range in rpm:</i> 0 ^P to 1000 ^P to 12000 ^P	√
G33	Reference speed slow: Only if G20 >0. Speed for final phase of referencing. <i>Value range in rpm:</i> 0 ^P to 300 ^P to 12000 ^P	√
G35	Ref.encoder signal 0: Only if G20 >0. Referencing to zero pulse of the motor encoder. Do not use for continuous mode with an odd-number gear ratio. 0: inactive; 1: active;	√
G38	Synchronous offset: Only if G20 >0. An offset distance based on the voltage on an analog input can be added to the current slave position. 10 V corresponds to the angle entered under G38 . <i>Value range in °:</i> -214748364.8 to 0 to 214748364.7	√

^P Depends on pole number **B10**; $f_{max} = 400$ Hz. With a 4-pole motor:, this is 12000 rpm at 400 Hz.

• The power pack must be turned off before these parameters can be changed.

Italics These parameters are sometimes not shown depending on which parameters are set.

1) See result table in chap. 15.

2) Only available if **D90**≠1

Parameters which are included in the *normal* menu scope (**A10**=0). For other parameters, select **A10**=1:extended or **A10**=2:service.

E Parameters marked with a "√" can be parameterized separately from each other in parameter record 1 and 2.

13. Parameter Description

G.. Technology		E
Para. No.	Description	
G40	Static friction torque: Only if G10 >0. Offset of the static friction (i.e., the friction (coulomb) independent of the speed). Value is converted to the motor shaft. <i>Value range in Nm: 0 to 327.67</i>	√
G41	Dynamic friction torque: Only if G10 >0. Offset of the speed-proportional friction. Value converted to the motor shaft at 1000 rpm. <i>Value range in Nm/1000 rpm: 0 to 327.67</i>	√
G42	T-dyn lowpass: Only if G10 >0. Torque for acceleration/deceleration can be offset dynamically. The load/motor inertia ratio with a full reel (D-Max) must be entered for this in parameter C30 . The acceleration portion to be offset is obtained by differentiation of the speed. G42 specifies the related smoothing time constant. <i>Value range in msec: 0 to 50 to 10000</i>	√
H.. Encoder		E
Para. No.	Description	
H20*	X20-function: 0: inactive; 1: inactive; (same function as H20 =2 but without wire-break monitoring). 2: encoder In; Connection of an incremental encoder with ROD signals. Wire-break monitoring active. 3: <i>stepmotor In</i> ; Stepper motor input function. Track A is the sign (low = positive, high = negative). Track B is the counting frequency (chapters 12.2 and 14.1). 4: inactive; 5: <i>SSI master</i> ; Connection of an SSI encoder (absolute value encoder). Note: SSI encoders can be used for both motor control and <i>POS!</i> . The absolute position for <i>POS!</i> can only be read from the encoder when the device starts up. If H20 is reparameterized and H20 was or is now H20 =5, this triggers fault "37:n-feedback" which cannot be acknowledged. Save values with A00 , and turn basic device off/on.	√
H21	Encodersim. increments: Only with option board <i>GB4001</i> Scaling ratio of the encoder signals output on X21 0: 1:1; Signal of the incremental encoder remains unchanged. 1: 1:2; Frequency is divided by 2. 2: 1:4; Frequency is divided by 4. 3: 1:8; Frequency is divided by 8. 4: 1:16; Frequency is divided by 16.	√
H22	X20-increments: Number of increments for incremental encoders. With SSI encoders, the range of H23 (X20 gear ratio) can be expanded with H22 . See chap. 10.11. H22 =1024 is the neutral setting. <i>Value range in I/R: 30 to 1024 to 4096</i>	√
H23	X20-gear ratio: Only if C60 =2. Conversion of an external posi encoder to the motor shaft. Caution: Parameter has no effect on the speed calculation for motor control (vector control). It is only used to convert the position of an external encoder. The following must be true: H23 = number of motor revolutions / number of encoder revolutions. If this formula results in values greater than 32.767, the number of encoder increments in H22 must be divided by a suitable factor (e.g., 2). The result of the above formula is then also divided and entered in H23 . See chapters 10.11.2. With SSI encoders, the gear ratio is expanded by setting H22 to a value other than 1024. <i>Value range: 0 to 1 to 32.767</i>	√
H60	SSI-invert: Reverse sign for external SSI encoders. Wrong sign → unstable control loops. 0: inactive; Clockwise revolution of motor shaft while facing the shaft (A side) counts as positive. 1: active; Counterclockwise revolution of motor shaft counts as negative.	√
H61	SSI-coding: Entry as per encoder data sheet. STÖBER motors: "0:gray." 0: gray; 1: binary;	√
H62	SSI-data bits: Entry as per encoder data sheet. STÖBER motors: 25 Bit. Cf. chap. 14.3. <i>Value range: 24 to 25</i>	√

^P Depends on pole number **B10**; $f_{max} = 400$ Hz. With a 4-pole motor, this is 12000 rpm at 400 Hz.

• The power pack must be turned off before these parameters can be changed.

Italics These parameters are sometimes not shown depending on which parameters are set.

1) See result table in chap. 15. 2) Only available if **D90**≠1

Parameters which are included in the *normal* menu scope (**A10**=0). For other parameters, select **A10**=1:extended or **A10**=2:service.

E Parameters marked with a "√" can be parameterized separately from each other in parameter record 1 and 2.

13. Parameter Description

I.. Posi. Machine		E
Para. No.	Description	
I09	Measurement unit: Only if I05=0 (user unit). Indication of the unit of measure defined as desired by the user with FDS Tool. Up to 4 characters can be used.	
I10	Max. speed: Unit/sec. Works simultaneously with the maximum motor speed in C01 . The actual speed limit corresponds to the lower of the two parameters. When a higher feed speed is specified, the value is limited to I10 or C01 without causing the following error. <i>Value range in I05/sec:</i> 0 to 10 to 31 bits	
I11	Max. acceleration: Units/sec ² . With quick stop, the drive decelerates with I11 . The acceleration for manual (I12) and reference point traversing (I33 , chap. 10.6) is also derived from I11 (i.e., each is ½ of I11). <i>Value range in I05/sec²:</i> 0 to 10 to 31 bits	
I12	Tip speed: Units/sec. Speed during manual operation (J03). As with all speeds, it can be changed via analog input AE2 (F20=5:Override). Acceleration during manual operation is ½ of I11 . <i>Value range in I05/sec:</i> 0 to 180 to 31 bits	
I15	Accel-override: Permits modification of the set ramps via AE2 (F20=5:Override). <i>0: inactive;</i> Ramps are not changed by override. Standard setting. <i>1: active;</i> Ramps are changed by override. Only recommended in exceptional cases (e.g., process block chaining without stop to generate simple n(x) speed profiles. Caution: The override value affects acceleration to the power of two. Danger of overload when override > 100%. During ramps, changes in accel-override are only adjusted slowly in a background task. When Accel-Override (I15=1) is activated, the override value should not be decreased to 0%. This would make the ramp infinitely long and the drive would never stop!	
I16	S-ramp: Reverse limitation through square sinus ramp. The generated acceleration profile is smoothed with the specified time constant. Positioning takes a little longer. <i>Value range in msec:</i> 0 to 32767	
I19	ENA-interrupting: In the default setting, removal of the enable causes the position controller to be reset (status "17:posi.active"). Particularly during continuous positioning, it is important that interrupted process blocks can be concluded after emergency off or similar. I19 offers particularly simple process block interruption. See also chap. 10.10. <i>0: inactive;</i> Enable-off resets the positioning controller. <i>1: active;</i> Enable-off while process block is running causes status "23:interrupted." The interrupted process block is completed with <i>Posi.step</i> . Not possible for process blocks which are chained <i>without Stop (J17=2)</i> .	
I20	Kv-factor: Gain of position controller (only P characteristic) with unit of 1/sec. The Kv factor is also known as the speed gain. In actual practice, the Kv factor is sometimes specified with the unit m/min/mm which is exactly 0.06 x I20 . See also block circuit diagram in chap. 10.7. <i>Value range in 1/sec:</i> 0 to 30 to 100	
I21	Max. following error: The output function (F00=9:follow.error) is activated when the following error defined in I21 is exceeded. The Windows program FDS Tool can then be used to specify as desired the reaction to the exceeded following error as a fault (default setting), warning or message. <i>Value range in I05:</i> 0 to 90 to 31 bits	
I22	Target window: Window for the output signal "reference value reached" (F00=3:RefVal-reached). I22 must be greater than I23! . <i>Value range in I05:</i> 0 to 5 to 31 bits	
I23	Dead band pos. control. "Dead zone" of the position controller. Useful to prevent idle-state oscillation particularly when an external position encoder is used and there is reversal play in the mechanics. Cf. chap. 10.7. Caution: I23 Dead band must be smaller than target window I22! <i>Value range in I05:</i> 0 to 31 bits	
I25	Speed feed forward: Switches the calculated speed profile to the output of the position controller (chap. 10.7). If there is overswinging in the destination position, I25 and C32 must be reduced. <i>Value range in %:</i> 0 to 80 to 100	
I30	Reference mode: For details on reference point traversing, see chapter 10.6. 0: reference input; When searching for the reference point, the reference input is the determining factor (i.e., the BE function "23:Reference input" must be parameterized). 1: stop input; The function of the reference input is fully covered by the stop switch (i.e., BE function "21:Stop +" or "22:Stop -" must be parameterized). When the starting direction is positive (I31=0), positive "Stop +" is required. Triggering the wrong stop switch causes a fault. 2: encoder signal 0; Only of interest for drives without a gearbox. Used to align the motor shaft to a defined position.	

^P Depends on pole number **B10**; $f_{max} = 400$ Hz. With a 4-pole motor, this is 12000 rpm at 400 Hz.

• The power pack must be turned off before these parameters can be changed.

Italics These parameters are sometimes not shown depending on which parameters are set.

1) See result table in chap. 15. 2) Only available if **D90**≠1

Parameters which are included in the *normal* menu scope (**A10=0**). For other parameters, select **A10=1:extended** or **A10=2:service**.

E Parameters marked with a "√" can be parameterized separately from each other in parameter record 1 and 2.

13. Parameter Description

I.. Posi. Machine		E
<i>Para. No.</i>	<i>Description</i>	
I30 <i>Continuation</i>	<p>3: define home; BE function "24:Start ref." or "J05 → 1" immediately sets the actual position to I34 without performing an additional movement. For example, this can be used to set the actual position to zero at all times (enable must be active).</p> <p>4: posi.start; Each <i>posi.start</i> signal causes reference position I34 to be set. This can be used, for example, to indicate the actual distance as the current position with relative positioning and offset of the traversing path via analog signal ("<i>1:additional reference value</i>" and "<i>4:reference value-faktor</i>").</p>	
I31	<p>Reference direction: Initial direction to take when searching for the reference point. Cf. chapter 10.6. If only one direction is permitted (I04>0), the reference traversing direction depends on I04 and not I31.</p> <p><i>0: positive;</i> <i>1: negative;</i></p>	
I32	<p>Reference speed fast: Speed for the first phase of reference point traversing (i.e., determining the rough area). Omitted when only one direction of rotation (I04) is permitted. Only the slow speed (I33) is then used for this type of reference point traversing.</p> <p><i>Value range in I05/sec: 0 to 90 to 31 bits</i></p>	
I33	<p>Reference speed slow: Speed for the final phase of reference point traversing. Switching between I32 and I33 is automatic. Cf. figures in chapter 10.6 The acceleration during reference point traversing is I11/2.</p> <p><i>Value range in I05/sec: 0 to 4.5 to 31 bits</i></p>	
I34	<p>Reference position: Value which is loaded to the reference point (e.g., provided by the reference switch or the stop switch) as the actual position. The drive stops after reference point traversing. The position is determined by brake ramp I11/2. Cf. chapter 10.6.</p> <p><i>Value range in I05: -31 bits to 0 to 31 bits</i></p>	
I35	<p>Ref.encoder signal 0: Only if I36=0 and I30≠2. Referencing to zero pulse of an incremental encoder.</p> <p><i>0: inactive;</i> Zero pulse is not evaluated. Referencing to the edge of the stop or reference switch. Important for continuous axes with transmissions, for example. Also useful when there are not enough binary inputs and demands on accuracy are not high.</p> <p><i>1: active;</i> Standard for precision drives. Zero track must be connected.</p>	
I36	<p>Continuous reference: Only for continuous axes (I31=1). Used for fully automatic compensation of slip or inexact gear ratio. After the reference points are traversed for the first time, actual position I80 is always overwritten with reference position I34 each time the reference switch is passed over in direction I31 (but only in this direction!). Since the path which is still to be traversed is corrected, the axis is able to perform any number of relative movements in one direction without drifting, even when drives have slip. If the reference switch is connected to BE3, the signal is processed immediately.</p> <p>Remember: When I36=1, the other edge of the reference switch is evaluated than for I36=0 during reference point traversing. Circular length I01 must be as close as possible to the path between two reference signals (e.g., after one belt rotation, the same position must be indicated). Check actual position I80 during a rotation with I36=0, and adjust I07 if necessary. The distance per rotation I07 must always be rounded to the next higher number to prevent undesired counterclockwise offsets. The reference switch should not be triggered during a deceleration ramp since a negative offset would cause a counterclockwise movement.</p> <p>Important: Target window I22 must be greater than the maximum physical inaccuracy!</p> <p><i>0: inactive;</i> <i>1: active;</i></p>	
I37	<p>Power-on reference: Automatic reference point traversing after power-on.</p> <p><i>0: inactive;</i> <i>1: posi.start;</i> After power-on, the inverter assumes operating mode "24:ref.wait." The first <i>posi.start</i> or <i>posi.stop</i> signal starts the reference point traversing procedure. <i>2: automatic;</i> Reference point traversing is started automatically as soon as the enable appears.</p>	
I38	<p>Reference block: Number of the process block (i.e., 1 to 8) which is to be automatically started at the end of reference point traversing. This can be used to put the drive into a defined position after the reference points have been traversed.</p> <p>Speed and acceleration are taken by process block I38.</p> <p><i>0: standstill. No automatic start.</i> <i>1 to 8: Number of the process block to be executed.</i></p>	
I40	<p>Posi.-step memory: Helpful during relative positioning of continuous axes.</p> <p><i>0: inactive;</i> <i>Posi.step</i> signals during a movement are ignored. <i>1: no stop;</i> <i>Posi.step</i> signals which arrive during a movement cause the current destination position to be changed immediately. The process block specified by the reference block or, if no reference block is defined, the currently selected process block takes over. Example: Two additional <i>posi.step</i> signals arrive during a relative movement of 100 mm. The drive then moves precisely 300 mm without stopping.</p>	

^P Depends on pole number B10; f_{max} = 400 Hz. With a 4-pole motor:, this is 12000 rpm at 400 Hz.

• The power pack must be turned off before these parameters can be changed.

Italics These parameters are sometimes not shown depending on which parameters are set.

1) See result table in chap. 15. 2) Only available if D90≠1

Parameters which are included in the *normal* menu scope (A10=0). For other parameters, select A10=1:*extended* or A10=2:*service*.

E Parameters marked with a "√" can be parameterized separately from each other in parameter record 1 and 2.

13. Parameter Description

I.. Posi. Machine		E
Para. No.	Description	
I50	Software-stop -: Only if I00=0 (limited position range). Effective only when axis is referenced. Positioning control rejects traversing jobs outside the software limit switches (message "51:Refused"). Manual-traversing and continuous process blocks are stopped at the software stops. <i>Caution:</i> Software stops do nothing to compensate when the permissible position range is exceeded due to a change on the fly to a process block with slower ramps! <i>Value range in I05:</i> -31 bits to 10000000 to 31 bits	
I51	Software-stop +: Only if I00=0 (limited position range). Effective only when axis is referenced. <i>Value range in I05:</i> -31 bits to 10000000 to 31 bits	
I60	Electronic cam 1 begin: In the positioning area between I60 and I61, the <i>el.cam</i> signal (relay 2, F00=8) becomes high. "Electronic cam" only functions in the referenced state. Cf. also the related function "operating range" in chapter 9.3. <i>Value range in I05:</i> -31 bits to 0 to 31 bits	
I61	Electronic cam 1 end: See I60. <i>Value range in I05:</i> -31 bits to 100 to 31 bits	
I70	Position-offset: A correction path corresponding to the voltage on AE2 can be added to the current reference value position (F20=6). 10 V corresponds to the path specified in I70. Useful, for example, for creating complicated x(t) profiles which are generated by a PC as voltage. After activation of the inverter (i.e., enable), the current offset value is approached at the manual speed I12. The reference value from AE2 is then supplied without restrictions, and the AE2 low pass can be used for smoothing. <i>Value range in I05:</i> 0 to 31 bits	
I80	Actual position: Read only. Indication of the actual position. <i>Value range in I05:</i> ±31 bits	
I81	Target position: Read only. Indication of the current reference value position. <i>Value range in I05:</i> ±31 bits	
I82	Active process block: Read only. Indication of the currently active block during block processing (traverse, wait) and during standstill at a process block position. The approached process block is indicated in I82 as long as the "RV reached" signal (i.e., in position) is present. When the drive in not in a process block position (e.g., after power on, manual traversing or termination of a movement), I82=0 applies. When I82>0, the signals "23: reference value-ackn.0" to "25: reference value-ackn.2" can indicate the active process block in binary coded format ("000" for process block 1 - i.e., I82=1). Cf. chap. 10.3.	
I83	Selected process block: Read only. Indication of the block selected via binary inputs or J02. This process block would be executed with the <i>posi.start</i> signal. Cf. also chap. 10.3 and F00=23.	
I84	Following error: Read only. Indication of the current position deviation. Cf. I21 and F00=9. <i>Value range in I05:</i> ±31 bits	
I85	In position: Read only. Indication of output signal F00=3:refVal-reached. 0: inactive; Drive moving or destination position not reached. 1: active; See output signal F00=3:refVal-reached and I22 target window.	
I86	Referenced: Read only. Indication of output signal "13:referenced." For ref. point traversing, see chap. 10.6. 0: inactive; Drive not referenced. No absolute positioning possible. 1: active; Drive referenced.	
I87	Electronic cam 1: Read only. Indication of output signal "8:electronic cam 1." 0: inactive; Current position is outside I60 and I61. 1: active; Current position is within I60 and I61.	
I88	Speed: Read only. Indication of the current actual value of the positioning speed with unit. Cf. chap. 10.7. <i>Value range in I05/sec:</i> ±31 bits	

J.. Posi. Command (Process Blocks)		E
Para. No.	Description	
J00	Posi.start: 0→1. Starts the currently selected process block. The block is selected via binary inputs (<i>RV-select</i> 0 to 2) or J02. Since <i>posi.start</i> interrupts positioning procedures in progress, it has the highest priority. The J00 parameter corresponds to the BE function <i>posi.start</i> .	
J01	Posi.step: 0→1. With process block chaining, <i>posi.step</i> is used to start the next programmed block when this is not started automatically (e.g., via J17=1:with delay). This is done without regard to the <i>RV-select</i> inputs, for example. In operating state "17:posi.active," (standstill, no process block being processed -> I82=0), <i>posi.step</i> starts the currently selected process block the same as <i>posi.start</i> (see above). <i>Posi.step</i> never interrupts a running movement (exception: I40=1). Delays between process blocks (J18) are prematurely concluded by <i>posi.step</i> . If a movement is interrupted with halt or quick stop (operating state "23:interrupt."), <i>posi.step</i> completes the interrupted process block.	

^P Depends on pole number B10; f_{max} = 400 Hz. With a 4-pole motor:, this is 12000 rpm at 400 Hz.

• The power pack must be turned off before these parameters can be changed.

Italics These parameters are sometimes not shown depending on which parameters are set.

1) See result table in chap. 15.

2) Only available if D90≠1

Parameters which are included in the *normal* menu scope (A10=0). For other parameters, select A10=1:extended or A10=2:service.

E Parameters marked with a "√" can be parameterized separately from each other in parameter record 1 and 2.

13. Parameter Description

J.. Posi. Command (Process Blocks)		E
<i>Para. No.</i>	<i>Description</i>	
J02	Process block number: Selection of the process block which can be started at all times with <i>posi.start</i> . <i>0</i> : external selection via binary inputs and the BE functions F31=RV-select 0 to 2. See also I83 . <i>1</i> to 8: fixed selection of the process block. RV-select signals are ignored.	
J03	Tip-mode: Manual operation via the device keyboard. See also F31=17 and F31=18 . <i>0</i> : inactive; <i>1</i> : active; The drive can be positioned with the ◀ and ▶ keys.	
J04	Teach-in: 0→1 starts the action (i.e., triggered manually). The current actual position is used as the destination of the currently selected process block and stored non-volatilely. Example: Normally, the desired position is approached manually and then accepted with teach-in. See also F31=25 .	
J05	Start reference: 0→1 starts the action (i.e., triggered manually). Reference point traversing can also be started via a binary input or automatically after power-on. See I37 and chapter 10.6 and F31=24 .	
J10	Position: Position specification. The value can also be changed during traversing, but the change does not take effect until the next <i>posi.start</i> command (if internal conversion has been concluded). Cf. F00=32 . <i>Value range in I05:</i> -31 bits to 0 to 31 bits	
J11	Position mode: There are 4 modes. Cf. chapter 10.4. <i>0</i> : relative; <i>1</i> : absolute; <i>2</i> : endless positive; With "continuous" position modes, destination position J10 can be disregarded. <i>3</i> : endless negative;	
J12	Speed: Unit/sec. Caution: If you enter a value greater than the maximum speed I10 in J12 , the actual traveling speed is limited to I10 . <i>Value range in I05/sec:</i> 0 to 1000 to 31 bits	
J13	Accel: Acceleration unit/sec ² . Caution: If the values J13 and J14 exceed the maximum acceleration I11 , acceleration during movement is limited to I11 . Software version 4.5: If the direction of rotation must be changed during a change in process blocks on the fly, the entire reversal procedure is performed with the Accel ramp (J13). <i>Value range in I05/sec²:</i> 0 to 1000 to 31 bits	
J14	Decel: Deceleration, unit/sec ² . <i>Value range in I05/sec²:</i> 0 to 1000 to 31 bits	
J15	Repeat number: Only available if J11=0:relative . If necessary, a relative movement can be repeated several times based on the value J15 . With J17=0 , <i>posi.step</i> is waited for after each partial movement. With J17=1 , the partial movements are run through automatically. Delay J18 is inserted between the movements. J15=0 means no repetition (i.e., one single movement). <i>Value range:</i> 0 to 254	
J16	Next block: Chaining of process blocks. Specification of a process block to which a jump is to be made at the end of the movement or after a <i>posi.next</i> signal. <i>0</i> : stop; No process block chaining. <i>1</i> to 8: Number of the next process block. Cf. chapter 10.8.	
J17	Next start: Only if J15≠0 or J16≠0 . J17 defines when and how the branch is made to next block J16 . <i>0</i> : posi.step ; Continued movement via <i>posi.step</i> function (rising edge). Cf. J01 . <i>1</i> : with delay ; Automatic continued movement after delay J18 expires. In contrast to J17=2 , an intermediate stop is also always performed with J18=0 . Delays between process blocks (J18) are prematurely concluded by <i>posi.step</i> . <i>2</i> : no stop ; When the reference position reaches the target position J10 , the speed is adjusted without halting (on-the-fly process block change without intermediate stop!). Drive travels to J10 <u>without braking</u> and then changes to process block J16 . Also useful for generating n(x) speed profiles with support points in up to 8 positions. Cf. I15 (no "refVal-reached" signal (F00=3) is output here. Cf. chapter 10.8, example 4. When process blocks are terminated with HALT of enable off, resumption of the terminated movement is <u>not</u> possible with <i>posi.step</i> . <i>3</i> : Posi.next ; The block change is performed on the fly with the <i>posi.next</i> function. If J17≠3 , <i>posi.next</i> has no effect. See also example 3 in chap. 10.8. If the next block is relative, it refers to the actual position at the time the process block changed. <i>4</i> : Operation range ; The block change is performed on the fly when the operating range (C41 to C46) is exited. Compare example 7 (press/screw) in chapter 10.9. If the next block is relative, it refers to the actual position at the time the process block changed. When a block change is performed on the fly without intermediate stop (J17=2, 3, 4), no refVal-reached signal (in position) is generated.	

P Depends on pole number **B10**; $f_{max} = 400$ Hz. With a 4-pole motor:, this is 12000 rpm at 400 Hz.

• The power pack must be turned off before these parameters can be changed.

Italics These parameters are sometimes not shown depending on which parameters are set.

1) See result table in chap. 15.

2) Only available if **D90≠1**

Parameters which are included in the *normal* menu scope (**A10=0**). For other parameters, select **A10=1:extended** or **A10=2:service**.

E Parameters marked with a "√" can be parameterized separately from each other in parameter record 1 and 2.

13. Parameter Description

J.. Posi. Command (Process Blocks) E

Para. No.	Description
J18	Delay: Parameter only available if J15 ≠0 or J16 ≠0 and J17 =1. Otherwise not shown. Delay before the repetition of relative movements (J15 ≠0) or before automatic change to the next record (J17 =1:with delay). After expiration of the delay time, movement is automatically resumed. A delay can be terminated (i.e., shortened) with the <i>posi.step</i> signal (rising edge). <i>Value range in sec:</i> 0 to 65.535

⇒ The process block no. 2 - no. 8 are identical. Process block no. 2 is at **J20 - J28**, process block no. 3 at **J30 - J38** etc.

L.. Posi. Command 2 (Expanded Process Block Parameters) E

Para. No.	Description
L10	Brake: Definition for process block no. 1. Only if F00 =1. Process block-related brake control (e.g., for lifting systems). After reaching destination position J10 , you can apply the brake controlled via relay 2. <i>0:</i> inactive; Destination position is held by the motor (i.e., position control). Brake is only applied when enable, halt, quick stop or fault is missing. <i>1:</i> active; After the destination position is reached, the brake is automatically applied. The next start command is delayed by the time F06 (brake release). With B25 =0 and applied brake, power can be disconnected from the motor so that it can cool off while waiting, for example.
L11	Switch A: Selection of the first switching point for process block no. 1. Up to two switching points ("switch A" and "switch B") can be used in each process block. Each of the four switching points defined in group N.. can be used in various process blocks. Cf. chap. 10.12. <i>0:</i> inactive; <i>1:</i> switch S1; <i>2:</i> switch S2; <i>3:</i> switch S3; <i>4:</i> switch S4;
L12	Switch B: Selection of the second switching point for process block no. 1. Cf. L11 . <i>Value range:</i> 0 to 4

⇒ Extended process block parameter are identical for all process blocks. Process block no. 1 is located at **L10 ... L12**, process block no. 2 at **L20 ... L22**, and so on.

M.. Menu Skip (Menu jump destinations) E

Para. No.	Description
M50	F1-jump to: Parameter provided by the F1 function key for editing. Depending on the device function, some parameters may not be shown and cannot be selected. <i>Value range:</i> A00 to E50 to N44
M51	F1-lower limit: <i>Value range:</i> depends on the parameter selected in M50
M52	F1-upper limit: <i>Value range:</i> depends on the parameter selected in M50

⇒ The jump destinations F2 to F4 are designed identically. Jump destination F2 is in **M60** to **M62**, and so on.

If several jump destinations (**M50**; **M60**; **M70** or **M80**) are parameterized to the same coordinates (e.g., **J10**), the lower, upper limit of the lowest jump destination takes effect.

^P Depends on pole number **B10**; $f_{max} = 400$ Hz. With a 4-pole motor, this is 12000 rpm at 400 Hz.

• The power pack must be turned off before these parameters can be changed.

Italics These parameters are sometimes not shown depending on which parameters are set.

1) See result table in chap. 15.

2) Only available if **D90**≠1

Parameters which are included in the *normal* menu scope (**A10**=0). For other parameters, select **A10**=1:extended or **A10**=2:service.

E Parameters marked with a "√" can be parameterized separately from each other in parameter record 1 and 2.

13. Parameter Description

N.. Posi. Switches		For description, see chap. 10.12.	E
Para. No.	Description		
N10	S1-position: Position of switching point S1. With relative specifications (N11 >0), the absolute value is generated internally. <i>Value range in I05:</i> -31 bits to 0 to 31 bits		
N11	S1-method: Reference of position N10 <i>0: absolute;</i> Switching point is triggered when position N10 is traveled over. <i>1: rel.to start;</i> Switching point is triggered after a distance of (N10) (absolute value) after the starting point. <i>2: rel.to endpos;</i> Switching point is triggered at a distance of (N10) before the destination position.		
N12	S1-memory1: When switch S1 is approached, switch memory 1 can be affected. <i>0: inactive;</i> <i>1: set;</i> Switch memory 1 is set to high. <i>2: clear;</i> Switch memory 1 is set to low. <i>3: toggle;</i> Switch memory 1 is inverted (Low → High → Low → ...).		
N13	S1-memory2: Behavior of switch memory 2. Cf. N12 . <i>Value range:</i> 0 to 3		
N14	S1-memory3: Behavior of switch memory 3. Cf. N12 . <i>Value range:</i> 0 to 3		

⇒ Posi switching points S2 to S4 are set up identically. Switching point S2 is located at **N20** to **N24**, and so on.

U.. Protective Functions			E
Para. No.	Description		
U00	Level low voltage: Is activated when the value U00 set in A35 is passed below. <i>2: warning;</i> after expiration of the tolerance time in U01 , the device assumes fault mode (for E46, see chap. 17). <i>3: fault;</i> the device assumes malfunction mode (for E46, see chap. 17) immediately after the value in A35 is passed below.		
U01	Time low voltage: Can only be set with U00 = <i>2:warning</i> . Defines the time during which triggering of undervoltage monitoring is tolerated. After expiration of this time, the device assumes fault mode. <i>Value range in sec:</i> 1 to 2 to 10		
U10	Level temp. limit mot. i2t: Parallel to the monitoring of the positor line in the motor, the FAS simulates the motor temperature via an i ² t model. The percentage of load of the motor is indicated in parameter E23 . If the value in E23 is greater than 100%, U10 is triggered. <i>0: off;</i> device does not react when U10 is triggered. <i>1: message;</i> triggering of U10 is only indicated. The device continues to be ready for operation. <i>2: warning;</i> after expiration of the tolerance time in U11 , the device assumes fault mode (for E45, see chap. 17).		
U11	Time temp. limit mot. i2t: Can only be set with U10 = <i>2:warning</i> . Defines the time during which the triggering of i ² t monitoring is tolerated. After expiration of the set time, the device assumes fault mode. <i>Value range in sec:</i> 1 to 30 to 120		
U20	Level drive overload: If the calculated torque in static operation exceeds the current M-Max in E62 , U20 is triggered. <i>0: off;</i> device does not react when U20 is triggered. <i>1: message;</i> triggering of U20 is only indicated. The device continues to be ready for operation. <i>2: warning;</i> after expiration of the tolerance time in U21 , the device assumes fault mode (for E47, see chap. 17). <i>3: fault;</i> the device immediately assumes fault mode (for E47, see chap. 17) after U20 is triggered.		
U21	Time drive overload: Can only be set with U20 = <i>2:warning</i> . Defines the time during which an overload of the drive is tolerated. After expiration of the set time, the device assumes fault mode. <i>Value range in sec:</i> 1 to 10 to 120		
U22	Text drive overload: The entry "drive overload" can be varied to suit user-specific requirements. <i>Value range:</i> 0 to "drive overload" to 11		
U30	Level acceleration overload: If the calculated torque exceeds the current M-Max in E62 during the acceleration ramp, U30 is triggered. <i>0:off;</i> device does not react when U30 is triggered. <i>1: message;</i> triggering of U30 is only indicated. The device continues to be ready for operation. <i>2: warning;</i> after expiration of the tolerance time in U31 , the device assumes fault mode (for E48, see chap. 17). <i>3: fault;</i> the device immediately assumes fault mode (for E48, see chap. 17) after U30 is triggered.		
U31	Time acceleration overload: Can only be set with U30 = <i>2:warning</i> . Defines the time during which drive overload during acceleration is tolerated. After expiration of the set time, the device assumes fault mode. <i>Value range in sec:</i> 1 to 5 to 10		

^P Depends on pole number **B10**; $f_{max} = 400$ Hz. With a 4-pole motor, this is 12000 rpm at 400 Hz.

• The power pack must be turned off before these parameters can be changed.

Italics These parameters are sometimes not shown depending on which parameters are set.

1) See result table in chap. 15.

2) Only available if **D90**≠1

Parameters which are included in the *normal* menu scope (**A10**=0). For other parameters, select **A10**=*1:extended* or **A10**=*2:service*.

E Parameters marked with a "√" can be parameterized separately from each other in parameter record 1 and 2.

13. Parameter Description

U.. Protective Functions		E
<i>Para. No.</i>	<i>Description</i>	
U32	Text acceleration overload: The entry "acceleration overload" can be varied to suit user-specific requirements. <i>Value range:</i> 0 to "acceleration overload" to 11	
U40	Level break overload: If the calculated torque exceeds the current M-Max in E62 during the deceleration ramp, U40 is triggered. <i>0: off;</i> device does not react when U40 is triggered. <i>1: message;</i> triggering of U40 is only indicated. The device continues to be ready for operation. <i>2: warning;</i> after expiration of the tolerance time in U41 , the device assumes fault mode (for E49, see chap. 17). <i>3: fault;</i> the device immediately assumes fault mode (for E49, see chap. 17) after U40 is triggered.	
U41	Time break overload: Can only be set with U40=2:warning . Defines the time during which an overload of the drive during deceleration is tolerated. After expiration of the set time, the device assumes fault mode. <i>Value range in sec:</i> 1 to 5 to 10	
U42	Text break overload: The entry "break overload" can be varied to suit user-specific requirements. <i>Value range:</i> 0 to "break overload" to 11	
U50	Level operating range If one or more of the parameters C41 to C46 are violated, U50 is triggered. <i>0: off;</i> device does not react when U50 is triggered. <i>1: message;</i> triggering of U50 is only indicated. The device continues to be ready for operation. <i>2: warning;</i> after expiration of the tolerance time in U51 , the device assumes fault mode (for E50, see chap. 17). <i>3: fault;</i> the device immediately assumes fault mode (for E50, see chap. 17) after U50 is triggered.	
U51	Time operating range: Can only be set with U50=2:warning . Defines the time tolerated outside the work area. After expiration of the set time, the device assumes fault mode. <i>Value range in sec:</i> 1 to 10 to 120	
U52	Text operating range: The entry "operating range" can be varied to suit user-specific requirements. <i>Value range:</i> 0 to "operating range" to 11	
U60	Level following error: If the value in I84 exceeds the value of I21 , U60 is triggered. <i>0: off;</i> device does not react when U60 is triggered. <i>1: message;</i> triggering of U60 is only indicated. The device continues to be ready for operation. <i>2: warning;</i> after expiration of the tolerance time in U61 , the device assumes fault mode (for E54, see chap. 17). <i>3: fault;</i> the device immediately assumes fault mode (for E54, see chap. 17) after U60 is triggered.	
U61	Time following error: Can only be set with U60=2:warning . Defines the time during which the value in I21 is exceeded. After expiration of the set time, the devices assumes fault mode. <i>Value range in msec:</i> 0 to 500 to 32767	
U70	Level posi. Refused: If the target position is located outside software stops I50 and 51 or an absolute process block is started in an unreferenced state (I86=0), U70 is triggered. <i>0: off;</i> device does not react when U70 is triggered. <i>1: message;</i> triggering of U70 is only indicated. The device continues to be ready for operation. <i>2: warning;</i> after expiration of the tolerance time of 1 sec, the device assumes fault mode (for E51, see chap. 17). <i>3: fault;</i> the device immediately assumes fault mode (for E51, see chap. 17) after U70 is triggered.	

^P Depends on pole number **B10**; $f_{max} = 400$ Hz. With a 4-pole motor, this is 12000 rpm at 400 Hz.

• The power pack must be turned off before these parameters can be changed.

Italics These parameters are sometimes not shown depending on which parameters are set.

1) See result table in chap. 15.

2) Only available if **D90**≠1

Parameters which are included in the *normal* menu scope (**A10=0**). For other parameters, select **A10=1:extended** or **A10=2:service**.

E Parameters marked with a "√" can be parameterized separately from each other in parameter record 1 and 2.

14. Option Boards
14.1 Option Board GB 4001 and EA 4001

GB4001	EA4001																																												
<p>Purpose: Encoder connection TTL or HTL and buffered encoder output TTL or HTL (can be switched), one binary output, external 24 V supply for encoder and inverter</p> <p>Application: High-quality encoder connection, synchronous running</p>	<p>Purpose: Encoder connection TTL or HTL (can be switched), 5 additional binary inputs, 1 binary output, external 24 V supply for encoder and inverter</p> <p>Application: Positioning, synchronous running</p>																																												
<p>Terminals: Plug connectors X20 and X21 on top of device</p> <div style="border: 1px solid black; padding: 5px; width: fit-content; margin: 10px auto;"> <p>Caution: Fixed encoder power supply $U_B = 18\text{ V}$</p> </div>	<p>Terminals: Plug connectors X20 and X21 on top of device</p> <p>* Bin. output BA2 is contained in basic device as relay2/BA2.</p> <p>EA-4000-compatible</p>																																												
<p>Plug connector X21: Buffered encoder output for GB4001</p> <p>1: Reference ground, connected internally with X20.7 + X20.9 2: BA1, binary output 3: /C Inverted encoder track C 4: C Encoder track C (zero track) 5: /B Inverted encoder track B 6: B Encoder track B 7: /A Inverted encoder track A 8: A Encoder track A</p> <div style="border: 1px solid black; padding: 5px; width: fit-content; margin: 10px auto;"> <p>Technical data, BA1: L level $\leq 1\text{ V}$ at 20 mA, $R_i = 10\ \Omega$ H level = $U_{ext} - 4\text{ V}$ at 20 mA, $R_i = 120\ \Omega$</p> </div> <p>Encoder output: $I_{max} = 20\text{ mA}$. Resolution can be set in 5 stages (1/1 to 1/16) with parameter H21.</p> <p>The encoder output can be switched between 5 V (plant setting) and 24 V (HTL) with a sliding switch in the middle of the board.</p> <p>Use shielded cable!</p>	<p>Plug connector X21: I/O expansion for EA4001</p> <p>A: BA4, Binary output, for data see BA1 (left) B: BA3, Binary output</p> <p>1: 0 V Ref. ground 2: BA1, Bin. output 3: BE10, Bin. input 4: BE9, Bin. input 5: BE8, Bin. input 6: BE7, Bin. input 7: BE6, Bin. input</p> <p>Technical data - binary inputs: L level: $\leq +8\text{ V}$, H level: $\geq +12\text{ V}$ Voltage limits: -10 V to +32 V, $R_i = 2.3\text{ k}\Omega$, $T_a = 4\text{ msec}$</p> <p>All BEs and BAs are equipped with optocouplers and are galvanically isolated from the basic device. Reference ground = terminal 1.</p>																																												
<p>Plug connector X20: Connection of incremental encoder and ext. 24 V with GB4001 and EA4001</p>																																													
<p>1: /C Inverted encoder track C (zero track) 2: C Encoder track C (zero track) 3: /B Inverted encoder track B (inv. frequency*) 4: B Encoder track B (frequency*) 5: /A Inverted encoder track A (inv. sign*) 6: A Encoder track A (sign*) 7: 0V Encoder power supply U_B, con. internally with X20.9 8: U_B Encoder power supply, $U_B = 18\text{ V}$, 200 mA 9: 0V External voltage supply 10: 24V External voltage supply, 20.4 V to 28.8 V DC, max. of 0.5 A</p> <p>Max. frequency = 500 kHz, min. pulse duration = 500 nsec</p> <p>Important: The negated tracks <u>must</u> be connected. All three tracks are monitored for wire break (fault "37:n-feedback"). This does not apply to the evaluation of the stepper motor signals. The signal rise time from 10% to 90% of the level must be $\leq 2\ \mu\text{sec}$. The type of option board is automatically recognized and indicated in parameter E54. The external 24 V voltage supply (terminals 9 and 10) <u>must</u> be connected and must already be present when the inverter is turned on.</p> <p>H20=2:encoder in specifies the X20 function as input for incremental encoder. The motor encoder must be set to B26=1:X20 with vector control via X20. The signals "direction" and "sign" can be used with H20=3:Stepmotor In as reference value for the electronic gearbox (activation with parameter G20).</p>	<p>The three sliding switches are used to switch the terminating resistors on tracks A, B and C between 1.6 kΩ (HTL encoder, plant setting) and 120 Ω for TTL encoder.</p> <table border="1" style="width: 100%; border-collapse: collapse;"> <thead> <tr> <th colspan="2">Connection of TTL and HTL encoder</th> </tr> </thead> <tbody> <tr> <td style="width: 30%;">PIN no. on STÖBER motor</td> <td> <table border="1" style="width: 100%; border-collapse: collapse;"> <tr> <td style="width: 20%;">(4) /C</td> <td style="width: 20%;">Gray</td> <td style="width: 20%;">1</td> <td style="width: 20%;">*</td> <td style="width: 20%;">Ψ=⊥=K</td> </tr> <tr> <td>(3) C</td> <td>Pink</td> <td>2</td> <td></td> <td></td> </tr> <tr> <td>(1) /B</td> <td>Yellow</td> <td>3</td> <td>*</td> <td>Ψ=⊥=K</td> </tr> <tr> <td>(8) B</td> <td>Green</td> <td>4</td> <td></td> <td></td> </tr> <tr> <td>(6) /A</td> <td>White</td> <td>5</td> <td>*</td> <td>Ψ=⊥=K</td> </tr> <tr> <td>(5) A</td> <td>Brown</td> <td>6</td> <td></td> <td></td> </tr> <tr> <td>(10) 0V</td> <td>Blue</td> <td>7</td> <td></td> <td></td> </tr> <tr> <td>(12) Red</td> <td>Red</td> <td>8</td> <td></td> <td></td> </tr> </table> <p>* Terminating resistance can be switched for HTL and TTL.</p> </td> </tr> </tbody> </table>	Connection of TTL and HTL encoder		PIN no. on STÖBER motor	<table border="1" style="width: 100%; border-collapse: collapse;"> <tr> <td style="width: 20%;">(4) /C</td> <td style="width: 20%;">Gray</td> <td style="width: 20%;">1</td> <td style="width: 20%;">*</td> <td style="width: 20%;">Ψ=⊥=K</td> </tr> <tr> <td>(3) C</td> <td>Pink</td> <td>2</td> <td></td> <td></td> </tr> <tr> <td>(1) /B</td> <td>Yellow</td> <td>3</td> <td>*</td> <td>Ψ=⊥=K</td> </tr> <tr> <td>(8) B</td> <td>Green</td> <td>4</td> <td></td> <td></td> </tr> <tr> <td>(6) /A</td> <td>White</td> <td>5</td> <td>*</td> <td>Ψ=⊥=K</td> </tr> <tr> <td>(5) A</td> <td>Brown</td> <td>6</td> <td></td> <td></td> </tr> <tr> <td>(10) 0V</td> <td>Blue</td> <td>7</td> <td></td> <td></td> </tr> <tr> <td>(12) Red</td> <td>Red</td> <td>8</td> <td></td> <td></td> </tr> </table> <p>* Terminating resistance can be switched for HTL and TTL.</p>	(4) /C	Gray	1	*	Ψ=⊥=K	(3) C	Pink	2			(1) /B	Yellow	3	*	Ψ=⊥=K	(8) B	Green	4			(6) /A	White	5	*	Ψ=⊥=K	(5) A	Brown	6			(10) 0V	Blue	7			(12) Red	Red	8		
Connection of TTL and HTL encoder																																													
PIN no. on STÖBER motor	<table border="1" style="width: 100%; border-collapse: collapse;"> <tr> <td style="width: 20%;">(4) /C</td> <td style="width: 20%;">Gray</td> <td style="width: 20%;">1</td> <td style="width: 20%;">*</td> <td style="width: 20%;">Ψ=⊥=K</td> </tr> <tr> <td>(3) C</td> <td>Pink</td> <td>2</td> <td></td> <td></td> </tr> <tr> <td>(1) /B</td> <td>Yellow</td> <td>3</td> <td>*</td> <td>Ψ=⊥=K</td> </tr> <tr> <td>(8) B</td> <td>Green</td> <td>4</td> <td></td> <td></td> </tr> <tr> <td>(6) /A</td> <td>White</td> <td>5</td> <td>*</td> <td>Ψ=⊥=K</td> </tr> <tr> <td>(5) A</td> <td>Brown</td> <td>6</td> <td></td> <td></td> </tr> <tr> <td>(10) 0V</td> <td>Blue</td> <td>7</td> <td></td> <td></td> </tr> <tr> <td>(12) Red</td> <td>Red</td> <td>8</td> <td></td> <td></td> </tr> </table> <p>* Terminating resistance can be switched for HTL and TTL.</p>	(4) /C	Gray	1	*	Ψ=⊥=K	(3) C	Pink	2			(1) /B	Yellow	3	*	Ψ=⊥=K	(8) B	Green	4			(6) /A	White	5	*	Ψ=⊥=K	(5) A	Brown	6			(10) 0V	Blue	7			(12) Red	Red	8						
(4) /C	Gray	1	*	Ψ=⊥=K																																									
(3) C	Pink	2																																											
(1) /B	Yellow	3	*	Ψ=⊥=K																																									
(8) B	Green	4																																											
(6) /A	White	5	*	Ψ=⊥=K																																									
(5) A	Brown	6																																											
(10) 0V	Blue	7																																											
(12) Red	Red	8																																											
<p>Interference immunity: EN 61000-4-4. All cables shielded. Cables: Use original STÖBER cables!</p>																																													

14. Option Boards

14.1 Option Board GB 4001 and EA 4001

14.2 Option Board for Ext. 24 V Power Supply

Connection of shield for option board (view from above)

Use the included EMC clip to attach the shield to the housing. See figures below. Press the clip together, and push it into the slit on the housing. Do not obstruct the marked area above the heat dissipater. Pliers can be used for demounting. Attachment of the shield is essential for EMC compliance.

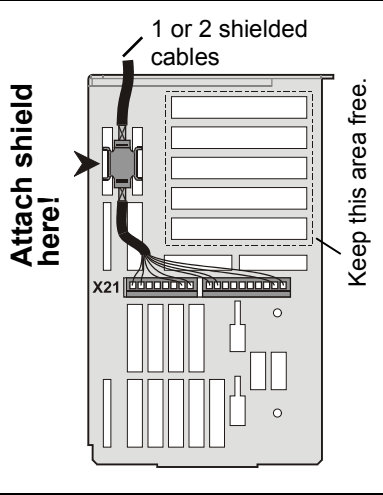
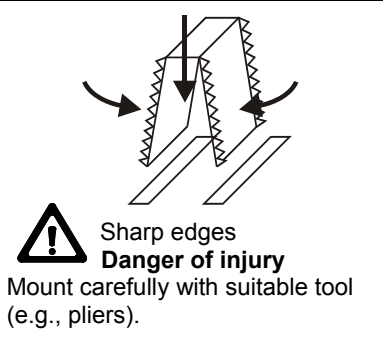
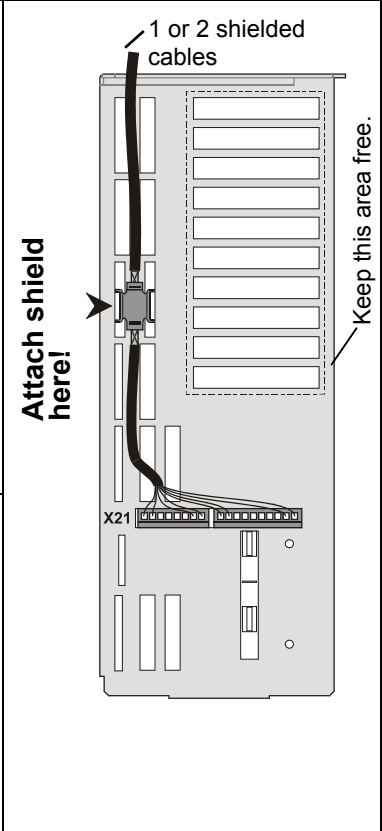
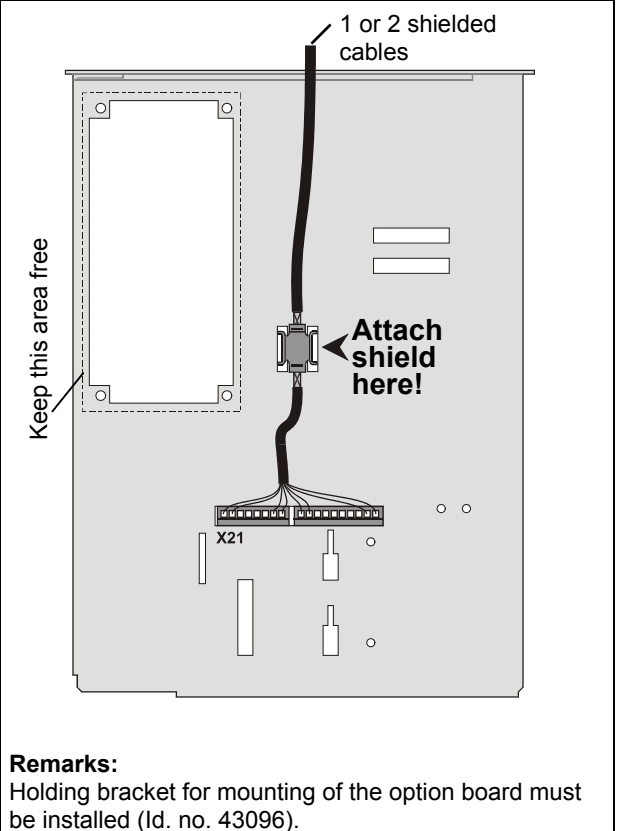
Model 1	Model 2	Model 3
 <p>Attach shield here!</p> <p>1 or 2 shielded cables</p> <p>X21</p> <p>Keep this area free.</p>  <p>Sharp edges Danger of injury Mount carefully with suitable tool (e.g., pliers).</p>	 <p>Attach shield here!</p> <p>1 or 2 shielded cables</p> <p>X21</p> <p>Keep this area free.</p>	 <p>Attach shield here!</p> <p>1 or 2 shielded cables</p> <p>X21</p> <p>Keep this area free.</p> <p>Remarks: Holding bracket for mounting of the option board must be installed (Id. no. 43096).</p>

Voltage selection encoder output (GB4001 only)

The voltage is selected with a sliding switch in the middle of the board. Default setting is 5 V (TTL). The actual voltage can be measured between terminals 7 and 8 on connector X21. Add the note "GB output = 24 V (HTL)" to your order if you want this default setting (only with boards installed).

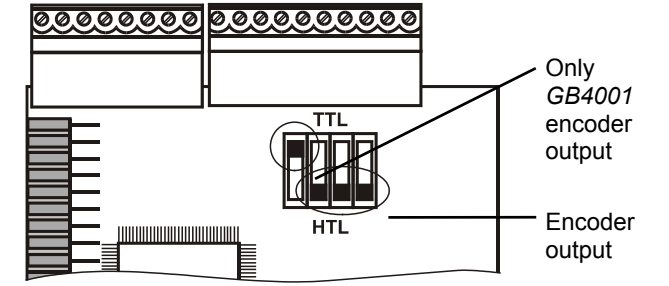

Mounting the option board

- The option board has usually been installed on delivery.
- If you have to install an option board yourself, open the housing (i.e., disconnect 2 screws on the front).
- Insert board in the upper portion of the housing at a slight angle. See figure.
- Remember to check the sliding switch for voltage adjustment.
- **Caution:** Be sure to use vertical position. Incorrect insertion by one pin row will damage the hardware.

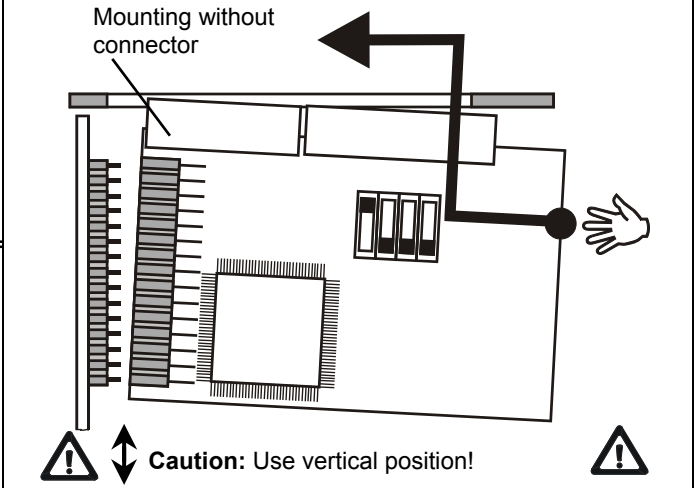

14.2 Option Board - Ext. 24 V Power Supply

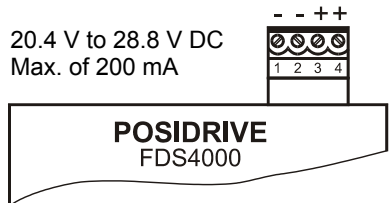

14. Option Boards
14.1 Option Board SSI-4000

SSI-4000

Purpose: Connection of multi-turn, absolute-value encoders with synchronous-serial interface (SSI) for positioning tasks
In addition: 5 binary inputs and 4 binary outputs plus external 24 V power supply for fieldbus systems

Terminals: Plug connector X20 and X21 on top of device

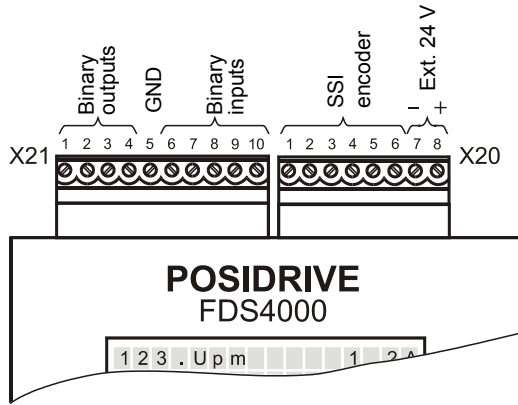

Primary parameters:

H20=5:SSI-master (X20 function = SSI)

SSI encoder on STÖBER system motor

B26=1:X20 (motor encoder on X20)

External encoder, incremental encoder on motor (chap. 10.11)

H23 X20-gear i (**H23**=n-motor / n-encoder)

H22 X20-increm. (only change if **n-motor / n-encoder** > 32)

H60 SSI-invert (change when control is unstable)

H61 SSI-coding (gray or binary)

H62 SSI-data bits (24 or 25)

I02 = 1:X20 (Posi-Encoder)

Fault "37:n-feedback" may occur with the parameterization. It can only be acknowledged by turning off power and 24 V. Don't forget: Save parameters with **A00=1** first!

Plug connector X21: I/O expansion

- | | |
|-----------------------|--|
| 1: BA5* Bin. output 5 | → Par. F84 |
| 2: BA4* Bin. output 4 | → Par. F83 |
| 3: BA3* Bin. output 3 | → Par. F82 |
| 4: BA1 Bin. output 1 | → Par. F80 |
| 5: GND Ground | |
| 6: BE10 Bin. input 10 | → Par. F64 , Inversion F74 |
| 7: BE9 Bin. input 9 | → Par. F63 , Inversion F73 |
| 8: BE8 Bin. input 8 | → Par. F62 Inversion F72 |
| 9: BE7 Bin. input 7 | → Par. F61 Inversion F71 |
| 10: BE6 Bin. input 6 | → Par. F60 Inversion F70 |

For tech. data of bin. outputs, see chap. 14.1, GB4001

* BA2 is contained in the basic device as "relay2/BA2" (parameter **F00 / F81**).

Technical data of the inputs

- L level ≤ +8 V, H level ≥ +12 V, Ri = 1.5 kOhm
- Ground connected internally on X21.5, X20.5 and X20.7 but galvanically isolated from the basic device
- Voltage limits: -10 V to +32 V
- Interference immunity: EN 61000-4-4

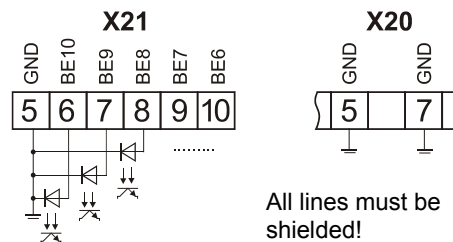

Plug connector X20: SSI encoder

(SSI encoder with supply voltage 11 to 30 V)

- 1: CLKP+ (RS 422, 5 V)
- 2: CLKP-
- 3: Data+ (RS 422, 5 V)
- 4: Data-
- 5: 0 V encoder
- 6: UB encoder (18 V DC, 200 mA)
- 7: 0 V ext. voltage
- 8: 24 V ext. power (20.4 to 28.8 V = 0.5 A)

Cables

- Use original STÖBER cables with double shielding!
- Do not connect "gray" and "pink" flexible leads.
- Twist CLKP and DATA in pairs and shield. Apply inner shield only to device.
- Apply outer shield on both sides.

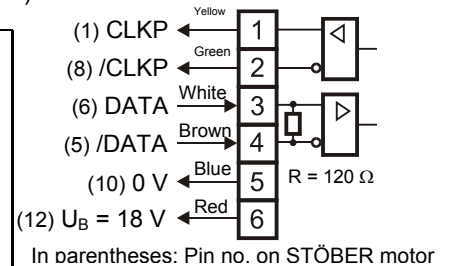

Supported: Multi-turn encoders with 4096 revolutions and 4096 or 8192 increments per revolution (24 or 25 data bits, can be set in parameter **H62**). Parameter **H22** (X20-increments) is usually left at 1024 (factory setting). The clock pulse frequency is 250 kHz. Gray or binary coding can be set in parameter **H61**.

A continuous zero point setting can be used with all available reference traversing modes (e.g., mode **I30=3:define home**). A (power failure proof) electronic gearbox on the inverter permits absolute position acquisition during 262,144 revolutions (4096 x 64) with linear axes or an unrestricted traversing area for continuous axes with any gearbox. When these capabilities are used, the zero position must be referenced again when the inverter is replaced.

The so-called multiple transmission of SSI encoders is used to detect faults. Each position is called twice. If the information does not match (e.g., due to EMC), fault "37:n-feedback" occurs. This fault can only be acknowledged by turning the power and 24 V off. Encoders without multiple transmission are also permitted.



Fault "37:n-feedback" also occurs when you switch the operating mode to position (**C60**→2).

Important note on commissioning: It is absolutely essential that the sequence of motor phases (U, V, W) be adhered to! If the wrong phase sequence is used, the drive revolves slowly with high current and does not react to the reference value.

15. Result Table

Result Table

The result of actions (e.g., save parameter (**A00=1**)) is indicated on the display. Possible results are listed below.

0: Error free	The data were transferred correctly.
1: Error!	General error (e.g., no Parabox connected when A01=1)
2: Wrong box	Software version of Parabox is not compatible (V 2.0 to 3.2).
3: Invalid data	Parabox contains invalid data. Write Parabox again, and repeat the procedure.
5: OK (adjusted)	Software version of Parabox and inverter differ in several parameters. Confirm with the  key. Message does not affect functionality of the inverter.
6: OK (adjusted)	Software version of Parabox and inverter differ in several parameters. Confirm with the  key. Message does not affect functionality of the inverter.
9: BE encoder signal	F34=14 and F35=15 must be set when F26=0:BE-encoder and control mode "vector control with 2-channel feedback" has been selected with B20=2 .
10: Limit	Value outside the value range
11: f(BE) > 80 kHz	Only if B20=2 and B26=0 . Maximum frequency on BE exceeds permissible limit value of 80 kHz. (n-Max/60) x incremental encoder > 80 kHz, or (C01/60) x F36 > 80 kHz.
12: X20 ?	H20 must be parameterized correctly with option boards <i>EA4001</i> , <i>GB4001</i> and <i>SSI-4000</i> .
13: BE cw/ccw	Programming F31=14 and F32=14 can be used to simulate the direction of rotation of inverters with software 3.2. The functions "direction of rotation," "halt," and "quick stop" may not be assigned to other BEs.
14: Canceled	<ul style="list-style-type: none"> Parabox actions A40/A41 could not be executed correctly. Action canceled (e.g., due to removal of enable). The current exceeded the permissible maximum value (e.g., short circuit or ground fault) during "autotuning" or "phase test" (B40, B41).
15: R1 too high	A stator resistance measured during "autotuning" (B41) was too high. Motor is circuited incorrectly. Motor cable is defective.
16: Phase fault U	Error in phase U
17: Phase fault V	Error in phase V
18: Phase fault W	Error in phase W
19: Symmetry	Error in symmetry of phases U, V and W. Deviation of a winding resistor by ±10%.
21: Enable ?	The enable must be present for actions J00/J01/J05 .

16. Operating States

Operating States

The operating state is indicated in the display and can be queried under **E80** during fieldbus access.

0: Ready	Inverter is ready.
1: Clockwise	Fixed positive speed
2: Counter-clockwise	Fixed negative speed
3: Acceleration	Acceleration procedure in progress (Accel)
4: Deceleration	Deceleration procedure in progress (Decel)
5: Halt	Halt command present
6: $n < n\text{-Min}$	Reference value $< n\text{-Min}$ (C00)
7: $n > n\text{-Max}$	Reference value greater than minimum of C01 and E126 (via analog input or fieldbus)
8: Illegal direction	Specified direction of rotation is not the permissible direction of rotation (C02).
9: Load start	Load start is active (C21 , C22).
10: Capturing	Capturing is active.
11: Quick stop	Quick stop is being performed.
12: Inhibited	This state prevents the drive from starting up unintentionally. Effective for: <ul style="list-style-type: none"> • Drive is turned on (power on) with enable=high (only if A34=0). • A fault is acknowledged with a low-high change in enable. • Opened load relay (no power and DC link below 130 V) • When the option board powers the basic device externally with 24 V (no network voltage) • When A30=2:fieldbus and the fieldbus sends an "inhibit voltage" control command, or the enable terminal becomes low, or a quick stop is concluded
13: Serial (X3)	Parameter A30 =1 parameterized. Inverter is controlled by the PC via serial interface.
14: Enabled	Only available with DRIVECOM profile. Bus connection.
15: Self test	A self test is being performed on the inverter. During startup with ext. 24 V, "15:Self test" is indicated until power-on.
16: Fault	The inverter's power pack is disabled.
17: Positioning-active	Position control is active. Waiting for a start command. Basic state of positioning control.
18: Moving <i>no.</i>	Processing a traversing job. Drive is moving. <i>No.</i> is the current process block (I82).
19: Delay <i>no.</i>	For process block chaining with defined delay or for repetition of relative movements. During a stop between two sequential jobs, the signal "in position" is generated, but the display shows "delay."
20: Wait <i>no.</i>	For process block chaining with defined manual start (i.e., wait for <i>posi.step</i> signal)
21: Referencing	During reference point traversing
22: Tip	During manual traversing
23: Interrupted	After an interrupted process block (i.e., halt or quick stop) with the option of continuing with the <i>posi.step</i> signal. <i>Posi.step</i> is then used to move to the original destination position regardless of whether the drive has been moved in the meantime. See chap. 10.10.
24: Reference wait	Wait for <i>posi.start</i> or <i>posi.step</i> signal to trigger reference point traversing after power on (I37 =1).
25: Stop input	Drive is positioned on stop input and can only be moved out of this position with manual or reference point traversing.
26: Parameter inhibit	During data transmission from PC to inverter, software on the PC deactivates the inhibit.

17. Faults / Events

Faults / Events

When faults occur, the inverter is no longer able to control the drive and is disabled. An entry is made in the fault memory (**E40/E41**), and relay 1 (ready for operation) releases. If installed when the fault occurs, the Parabox is written automatically. Certain events (cf. last column of the table below) can be declared via FDS Tool as faults, messages, warnings or not effective.

		Auto Reset	FDS Tool*
31: Short/ground	The hardware overcurrent switch-off is active. • Motor requires too much current from the inverter (e.g., interwinding fault or overload).		
32: Short/gr. int.	When the inverter is enabled, an internal check is performed. A short circuit triggers a fault. • An internal device fault has occurred (e.g., IGBT modules are defective).		
33: Overcurrent	• Acceleration times too short. Lengthen ramps in group D . • Check torque limits C03 / C04 . - Which torque limits are in effect? See chapter 8.2. - Reduce torque limits C03/C04 set to maximum value by approx. 10 %. • Optimize parameter C30 (ratio of the moments of inertia). • With vector control (B20=2): encoder connected incorrectly to motor or to no motor at all.	√	
34: Hardw. fault	The non-volatile data memory (NOVRAM) is defective or software version is time-limited.		
35: Watchdog	Monitors the load and functions of the microprocessor. This malfunction may also be caused by EMC problems (e.g., shield of the motor cable or PE conductor not connected at all or connected incorrectly).	√	
36: High voltage	DC-link voltage too high • Power too high • Reverse powering of the drive while braking (no brake resistor connected, brake chopper deactivated with A20=0:inactive or defective) • Braking resistor with too low resistance value (overcurrent protection) • Automatic ramp extension at U_{max} is possible with A20=1 and A22=0 .	√	
37: n-feedback	With EA4001 / GB4001 : Wire break on one of the three encoder tracks With SSI-4000 : • Device startup with SSI-4000 : - No encoder connected - Encoder does not respond within 4 sec. - Option board without 24 V - No SSI-4000 option board on the device • In operation with SSI-4000 - Errors during double transfer (EMC problems ??) - Option board fails. - Change of H20 to/from SSI master - Change of C60 to "2:position" and I02=SSI-encoder		
38: tempDev.sens	The temperature E25 measured by the device sensor is greater than the limit value. • Temperature of environment/switching cabinet is too high.		
39: TempDev.i ² t	The i ² t model calculated for the inverter has reached 100% of the thermal load. • Inverter is overloaded. • Temperature of the environment/switching cabinet is too high.		
40: Invalid data	The data in non-volatile memory are incomplete (power was turned off during " A00 save values." Load data record again to the device, or check the parameters in the menu and execute A00 again.		
41: Temp.motorTMP	Excessive temperature indicated by the motor temperature sensor. Connection terminal X2.1 to X2.2. • Motor is overloaded. Use external ventilation • Temperature sensor not connected (if not present, jumper -> X2.1 - X2.2)		
42: Temp.brakeRes	The i ² t model for the braking resistor reaches 100% thermal load.		√
43: RV wire brk	Only if the reference value is calculated with the reference value characteristic (reference value specification via analog input 1 or frequency reference value), and reference value monitoring is activated (D08=1). • The reference value output is 5% less than the minimum permissible reference value (D05).		√
44: Ext.fault	Can be triggered by binary input or fieldbus (F31=12)		

Caution:
With **SSI-4000**, the fault can only be acknowledged by power or 24 V off.

* Events can be programmed with FDS Tool as messages, warnings or faults, or can be completely deactivated.

17. Faults / Events



Faults / Events

When faults occur, the inverter is no longer able to control the drive and is disabled. An entry is made in the fault memory (**E40/E41**), and relay 1 (ready for operation) releases. If installed when the fault occurs, the Parabox is written automatically. Certain events (cf. last column of the table below) can be declared via FDS Tool as faults, messages, warnings or not effective.

		Auto Reset	FDS Tool*
45: OTempMot.i ² t	The motor is overloaded.		√
46: Low voltage	DC-link voltage is below the limit value set in A35 . <ul style="list-style-type: none"> • Drops in the power supply. • Acceleration times are too short (ramps, D ..). • Fault is also triggered when option board is used (24 V external supply) when the power supply drops while the enable is active. • Failure of a phase with 3~ connection. 	√	√
47: Device overl.	The maximum torque permitted for static operation has been exceeded. The permissible torque is limited by parameters C03 and C04 and the possible torque limitation via analog input. See F20=2 or F25=2 and chap. 9.2.	√	√
48: Accel.overl.	Same as "47:Device overload" except for an acceleration procedure. M-Max 2 (C04) is permitted for the acceleration procedure with "cycle characteristic" startup (C20=2).	√	√
49: Decel.overl.	Same as "47:Device overload" except for a deceleration procedure	√	√
50: Operat.area	The operating area defined under C41 to C46 has been exited. See also chap. 9.3.	√	√
51: Refused	Only for positioning (C60=2). <i>Posi.start</i> or <i>posi.step</i> was not accepted and the RV-reached signal ("in position") is reset. <ul style="list-style-type: none"> • Destination position is located outside software limit switches I50 and I51. • In non-referenced status (I86=0), no absolute positions (e.g., J11=1) are traveled to. • The direction of rotation in the current process block is not the same as the permissible direction I04. 	√	√
52: Communication	<ul style="list-style-type: none"> • Fault during communication between inverter and FDS Tool during remote control via PC • Communication fault during fieldbus operation (Kommubox) 	√	
53: Stop input	A limit switch connected via a BE input has been triggered, or the traversing area permitted by software limit switches I50 and I51 has been exited. During referencing at the limit switch (I30=1), a reversal of the limit switches will cause a fault.		
54: Follow. error	The maximum following error (i.e., deviation between actual position and reference value position) permitted by I21 has been exceeded. Possible causes: Motor overload, too much acceleration or blockage		√
55: OptionBoard	<ul style="list-style-type: none"> • When option board EA4001 (EA-4000) or GB4001 (GB-4000) is used, the external 24 V voltage is not present or the card is defective. No fault if enable is deactivated. • No option board found (e.g., if B26=1:Option (X20)) When functions of an option board (binary inputs, encoder) are parameterized, an option board is requested. Check parameters B26 , G27 , I02 . Check F31 to F35 and F60 to F68 and change to "0:inactive" if necessary.		

√ The events checked in the "FDS Tool" column can be parameterized with FDS Tool as messages, warnings or faults in the group **U..** protective functions.

Acknowledgment of faults:

- **Enable:** Change from low to high level on the enable input.
Always available.
 -  -key (only if **A31=1**).
 - **Auto-reset** (only if **A32=1**).
 - **Binary input** (**F31** to **F35=13**).
- }  **Caution!** Drive starts up immediately!

Parameters **E40** and **E41** can be used to scan the last 10 faults (i.e., value 1 is the last fault). FDS Tool can then be used to indicate under "**S..** fault memory" many details on the last faults which occurred.

18. Block Circuit Diagram Synchronous Running

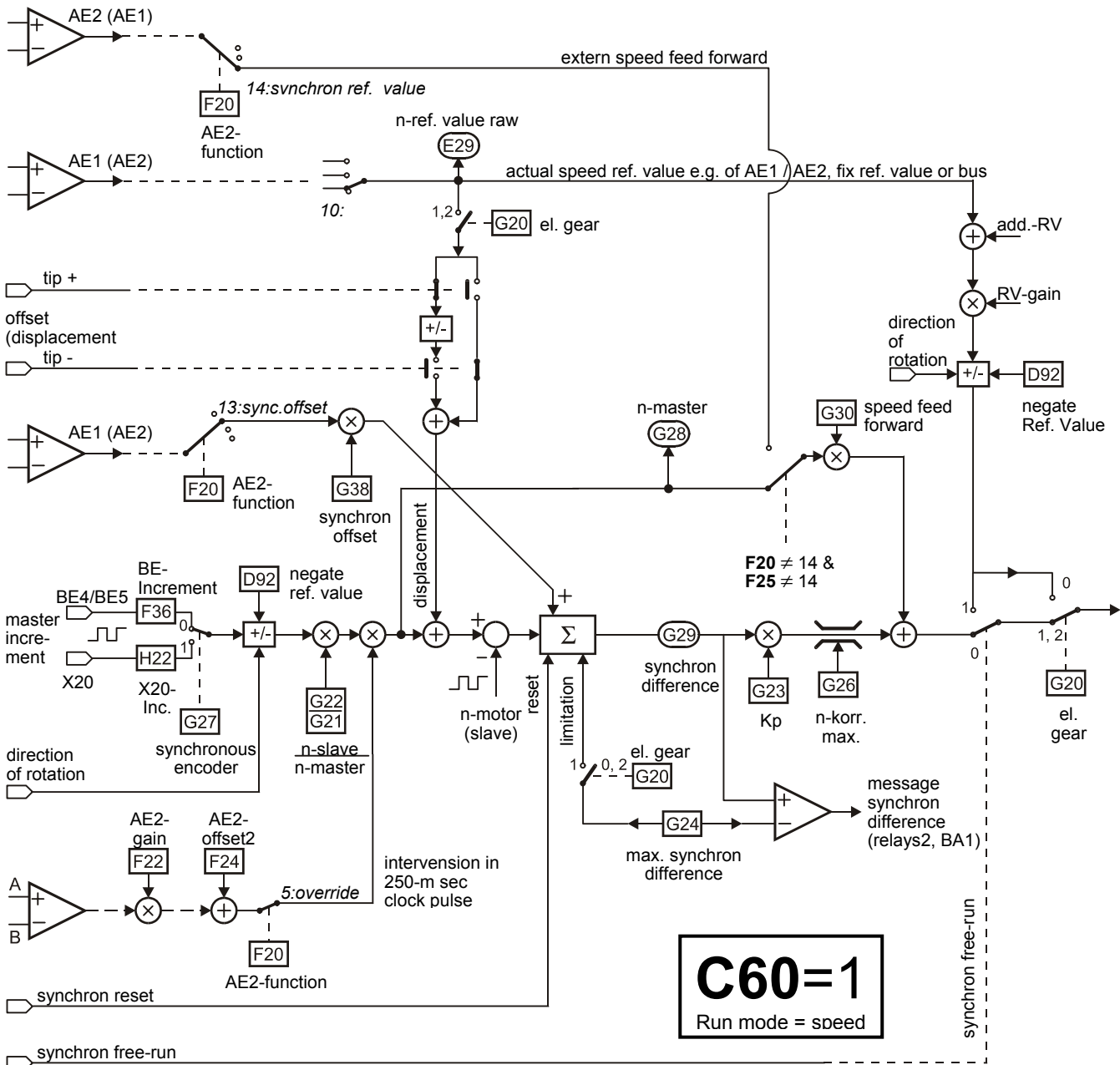

19. Block Circuit diagram Reference Value Processing

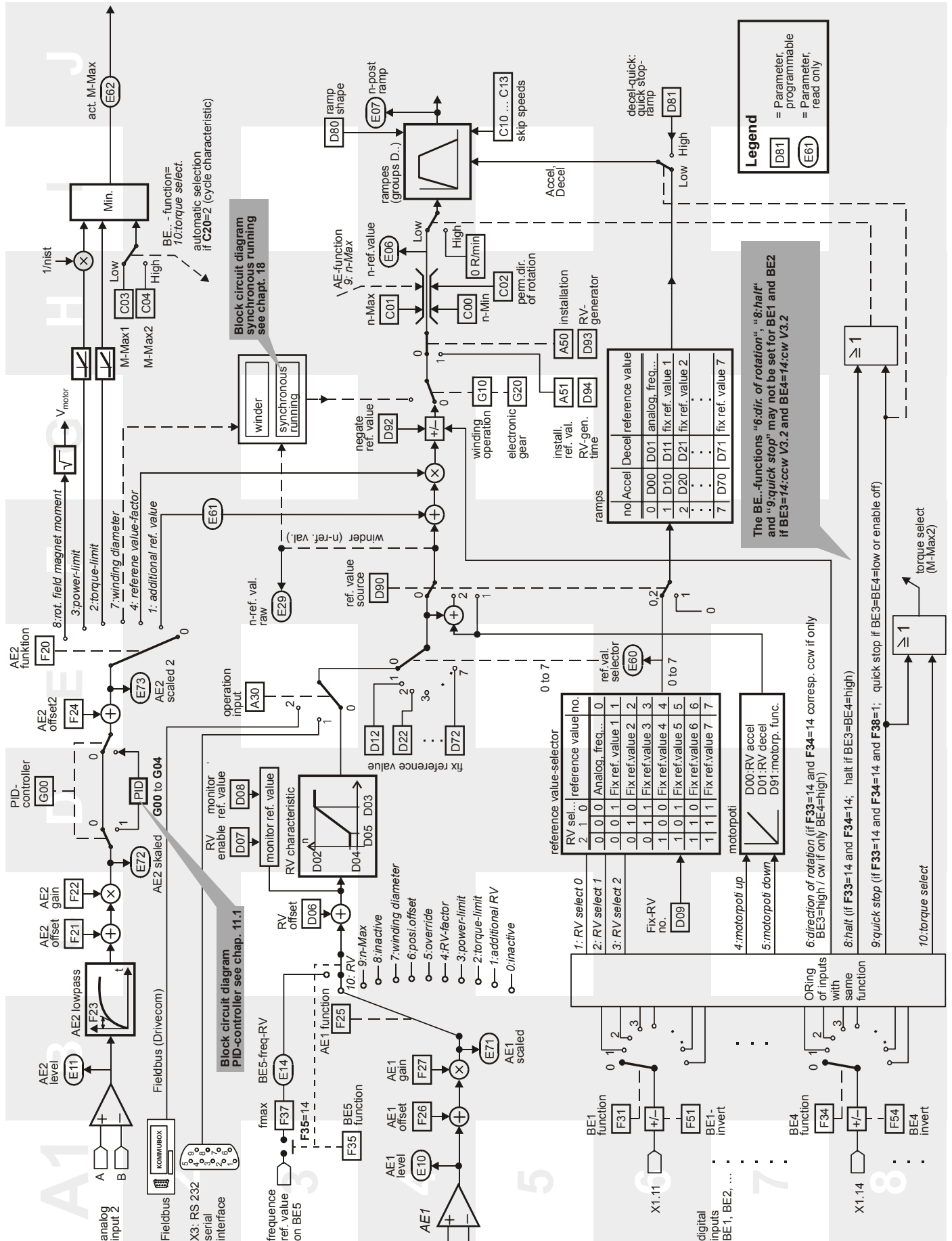

20. Parameter Table

Parameter	DS	Entry
A.. Inverter		
A00 Save parameter [%]		
A01 Read parabox & save [%]		
A02 Check parameter [%]		
A03 Write to parabox [%]		
A04 Default settings [%]		
A10 Menu level	0	
A11 Parameter set edit		
A12 Language	0	
A13 Set password		
A14 Edit password		
A15 Auto-return	1	
A20 Braking resistor type	0	
A21 Brak. resistor resist. [Ω]	600	
A22 Brak. resistor rating [kW]	*	
A23 Brak. resistor therm [sec]	40	
A30 Operation input	0	
A31 Esc-reset	1	
A32 Auto-reset	0	
A33 Time auto-reset [min]	15	
A34 Auto-start	0	
A35 Low voltage limit [V]	1~120 3~350	
A36 Mains voltage [V]	1~230 3~400	
A37 Reset memorized values		
A40 Read parabox [%]		
A41 Select parameter set		
A42 Copy para set 1>2 [%]		
A43 Copy para set 2>1 [%]		
A50 Installation		
A51 Install. ref. value [rpm]	300	
A55 Tip function key	1	
A80 Serial address	0	
A82 CAN-baudrate	1	
A83 Busaddress	0	
A84 Profibus baudrate		
B.. Motor		
B00 Motor-type		
B10 Poles	4	
B11 P-nominal [kW]	*	
B12 I-nominal [A]	*	
B13 n-nominal [rpm]	*	
B14 V-nominal [V]	*	
B15 f-nomial [Hz]	50	
B16 cos PHI	*	
B20 Control mode	1	
B21 V/f-characteristic	0	
B22 V/f-gain [%]	100	
B23 Boost [%]	10	
B24 Switching freq. [kHz]	4	
B25 Halt flux	1	
B26 Motor-encoder	0	
B27 Time halt flux [sec]	0	
B30 Add. motor-operation	0	
B31 Oscillation damping [%]	30	
B32 SLVC-dynamics [%]	70	
B40 Phase test [%]		
B41 Autotuning [%]		
B53 R1-motor [Ω]	*	

Parameter	DS	Entry
B64 Ki-IQ (moment) [%]	*	
B65 Kp-IQ (moment) [%]	*	
C.. Machine		
C00 n-Min [rpm]	0	
C01 n-Max [rpm]	3000	
C02 Perm. dir. of rotation	0	
C03 M-Max 1 [%]	150	
C04 M-Max 2 [%]	150	
C10 Skip speed 1 [rpm]	0	
C11 Skip speed 2 [rpm]	0	
C12 Skip speed 3 [rpm]	0	
C13 Skip speed 4 [rpm]	0	
C20 Startup mode	0	
C21 M-load start [%]	100	
C22 t-load start [s]	5	
C30 J-mach/J-motor	0	
C31 n-controller Kp [%]	60	
C32 n-controller Ki [%]	30	
C35 n-control. Kp standstill [%]	100	
C40 n-window [rpm]	30	
C41 Oper. range n-Min [rpm]	0	
C42 Oper. range n-Max [rpm]	6000	
C43 Operat. range M-Min [%]	0	
C44 Operat. range M-Max [%]	400	
C45 Operat. range P-Min [%]	0	
C46 Operat. range P-Max [%]	400	
C47 Operat. range C45/C46	0	
C48 Operat. range C47 abs	0	
C49 Operat. range accel&ena	0	
C50 Display function	0	
C51 Display factor	1	
C52 Display decimals	0	
C53 Display text		
C60 Run mode	1	
D.. Reference Value		
D00 RV accel [sec/150Hz]	3	
D01 RV decel [sec/150Hz]	3	
D02 Speed (max. RV) [rpm]	3000	
D03 Ref. value-Max. [%]	100	
D04 Speed (min. RV) [rpm]	0	
D05 Ref. value-Min [%]	1	
D06 Ref. value offset [%]	0	
D07 Ref. value enable	0	
D08 Monitor ref. value	0	
D09 Fix reference value no.	0	
D10 Accel 1 [sec/150Hz]	6	
D11 Decel 1 [sec/150Hz]	6	
D12 Fix ref. value 1 [rpm]	750	
D20 Accel 2 [sec/150Hz]	9	
D21 Decel 2 [sec/150Hz]	9	
D22 Fix ref. value 2 [rpm]	1500	
D30 Accel 3 [sec/150Hz]	12	
D31 Decel 3 [sec/150Hz]	12	
D32 Fix ref. value 3 [rpm]	3000	
D40 Accel 4 [sec/150Hz]	0,5	
D41 Decel 4 [sec/150Hz]	0,5	
D42 Fix ref. value 4 [rpm]	500	
D50 Accel 5 [sec/150Hz]	1	
D51 Decel 5 [sec/150Hz]	1	

Parameter	DS	Entry
D52 Fix ref. value 5 [rpm]	1000	
D60 Accel 6 [sec/150Hz]	2	
D61 Decel 6 [sec/150Hz]	2	
D62 Fix ref. value 6 [rpm]	2000	
D70 Accel 7 [sec/150Hz]	2,5	
D71 Decel 7 [sec/150Hz]	2,5	
D72 Fix ref. value 7 [rpm]	2500	
D80 Ramp shape	0	
D81 Decel-quick [sec/150Hz]	0,2	
D90 Reference value source	0	
D91 Motorpoti function	0	
D92 Negate reference value	0	
D93 RV-generator	0	
D94 Ref. val. generator time [msec]	500	
D98 Ramp factor	0	
E.. Display Values		
E00 I-motor [A]		
E01 P-motor [kW]		
E02 M-motor [Nm]		
E03 DC-link-voltage [V]		
E04 V-motor [V]		
E05 f1-motor [Hz]		
E06 n-reference value [rpm]		
E07 n-post-ramp [rpm]		
E08 n-motor [rpm]		
E09 Rotor position [U]		
E10 AE1-level [%]		
E11 AE2-level [%]		
E12 ENA-BE1-BE2-level		
E13 BE3-BE4-BE5-level		
E14 BE5-freq. ref. value [%]		
E15 n-encoder [rpm]		
E16 Analog-output-level [%]		
E17 Relay 1		
E18 Relay 2		
E19 BE15...BE1 & enable		
E20 Device utilization [%]		
E21 Motor utilization [%]		
E22 i2t-device [%]		
E23 i2t-motor [%]		
E24 i2t-braking resistor [%]		
E25 Device temperature [°C]		
E26 Binary output 1		
E27 BA15...BA1 & Relais 1		
E29 n-ref. value raw [rpm]		
E30 Run time [h,m,sec]		
E31 Enable time [h,m,sec]		
E32 Energy counter [kW]		
E33 Vi-max-memo value [V]		
E34 I-max-memo value [A]		
E35 Tmin-memo value [°C]		
E36 Tmax-memo value [°C]		
E37 Pmin-memo value [kW]		
E38 Pmax-memo value [kW]		
E40 Fault type		
E41 Fault time		
E42 Fault count		
E45 Control word		
E46 Status word		

20. Parameter Table

Parameter	DS	Entry
E47	n-field-bus [rpm]	
E50	Device	
E51	Software-version	
E52	Device-number	
E53	Variant-number	
E54	Option-board	
E55	Identity-number	
E56	Parameter set ident. 1	
E57	Parameter set ident. 2	
E58	Kommubox	
E60	Reference value selector	
E61	Additional ref. value [rpm]	
E62	Actual M-max [%]	
E63	PID-controller limit	
E65	PID-error [%]	
E71	AE1 scaled [%]	
E72	AE2 scaled [%]	
E73	AE2 scaled 2 [%]	
E80	Operating condition	
E81	Event level	
E82	Event name	
E83	Warning time	
E84	Active parameter set	
F.. Control Interface		
F00	Relay2-function	0
F01	Brake release [rpm]	0
F02	Brake set [rpm]	0
F03	Relay2 t-on [sec]	0
F04	Relay2 t-off [sec]	0
F05	Relay2 invert	0
F06	t-brake release [sec]	0
F07	t-brake set [sec]	0
F10	Relay1-function	0
F19	Quick stop end	0
F20	AE2-function	0
F21	AE2-offset [%]	0
F22	AE2-gain [%]	100
F23	AE2-lowpass [msec]	0
F24	AE2-offset2 [%]	0
F25	AE1-function	10
F26	AE1-offset [%]	0
F27	AE1-gain [%]	100
F30	BE-logic	0
F31	BE1-function	8
F32	BE2-function	6
F33	BE3-function	1
F34	BE4-function	2
F35	BE5-function	0
F36	BE4/BE5-increment [l/R]	1024
F37	fmax freq.-ref. val. [kHz]	51,2
F38	Quick stop	0
F40	Analog-output-function	0
F41	Analog-output-offset [%]	0
F42	Analog-output-gain [%]	100
F43	Analog-output1-absolut	0
F49	BE-gear ratio	1
F51	BE1-invert	0
F52	BE2-invert	0
F53	BE3-invert	0
F54	BE4-invert	0

Parameter	DS	Entry
F55	BE5-invert	0
F60	BE6-function	0
F61	BE7-function	0
F62	BE8-function	0
F63	BE9-function	0
F64	BE10-function	0
F65	BE11-function	0
F66	BE12-function	0
F67	BE13-function	0
F68	BE14-function	0
F70	BE6-invert	0
F71	BE7-invert	0
F72	BE8-invert	0
F73	BE9-invert	0
F74	BE10-invert	0
F80	BA1-function	1
F81	Relay2-function	0
F82	BA3-function	1
F83	BA4-function	1
F84	BA5-function	1
G.. Technology		
G00	PID-controller	0
G01	PID-controller Kp	0,3
G02	PID-controller Ki [1/sec]	0
G03	PID-controller Kd [msec]	0
G04	PID-controller limit [%]	400
G05	PID-controller limit2 [%]	-400
G06	PID-controller Kp2	1
G10	Winding operation	0
G11	Diameter	0
G12	Min. winding diam. [mm]	10
G13	Max. winding diam. [mm]	100
G14	Beg. winding diam. [mm]	10
G15	Overdrive ref. value [rpm]	0
G16	Diam.calculator ramp [mm/s]	10
G17	Tension reduction [%]	0
G19	Winding act. diam. [mm]	
G20	Electronic gear	0
G21	Speed master	1
G22	speed slave	1
G23	Kp synchron [1/sec]	30
G24	Max. sync. difference [°]	3600
G25	Synchron reset	3
G26	n-correction-Max. [rpm]	3000
G27	Synchronous encoder	0
G28	n-Master [rpm]	
G29	Synchron difference [°]	0
G30	Speed feed forward [%]	80
G31	Reference direction	0
G32	Reference speed fast [rpm]	1000
G33	Reference speed slow [rpm]	300
G35	Ref.encoder signal 0	0
G38	Synchronous offset [°]	0
G40	Static friction torque [Nm]	0
G41	Dyn. friction torque [Nm/100rpm]	0
G42	T-dyn lowpass [msec]	50
H.. Encoder		
H20	X20-function	1
H21	Encodersim. increments	0
H22	X20-increments [l/R]	1024

Parameter	DS	Entry
H23	X20-gear ratio	1
H60	SSI-invert	0
H61	SSI-coding	0
H62	SSI-data bits	25
I.. Posi. Machine		
I00	Position range	1
I01	Circular length [I05]	360
I02	Posi-encoder	2
I03	Direction optimization	1
I04	Move direction	0
I05	Measure unit selection	2
I06	Decimal digits	2
I07	Way/rev. numerator [I05]	360
I08	Way/rev. denomin. [R]	1
I09	Measurement unit	
I10	Max. speed [I05/sec]	10
I11	Max. accel. [I05/sec²]	10
I12	Tip speed [I05/sec]	180
I15	Accel-override	0
I16	S-ramp [msec]	0
I19	ENA-interrupting	0
I20	Kv-factor [1/sec]	30
I21	Max. following error [I05]	90
I22	Target window [I05]	5
I23	Dead band pos. control [I05]	0
I25	Speed feed forward [%]	80
I30	Reference mode	0
I31	Reference direction	0
I32	Ref. speed fast [I05/sec]	90
I33	Ref. speed slow [I05/sec]	4,5
I34	Reference position [I05]	0
I35	Ref. encoder signal 0	0
I36	Continuous reference	0
I37	Power-on reference	0
I38	Reference block	0
I40	Posi.-step memory	0
I50	Software-stop - [I05]	-10000000
I51	Software-stop + [I05]	10000000
I60	Electr. cam begin [I05]	0
I61	Electronic cam end [I05]	100
I70	Position-offset [I05]	0
I80	Actual position [I05]	
I81	Target position [I05]	
I82	Active process block	
I83	Selected process block	
I84	Following error [I05]	
I85	In position	
I86	Referenced	
I87	Electronic cam 1	
I88	Speed [I05/sec]	
J.. Posi. Command		
J00	Posi.start	
J01	Posi.step	
J02	Process block number	0
J03	Tip-mode	
J04	Teach-in	
J05	Start reference	

 = Standard menu level. Cf. para A10
Extended menu level: A10=1

DS = Default setting

* = Depends on type

20. Parameter Table

Parameter		DS	Entry Process Block 1 - 8							
			Block 1	Block 2	Block 3	Block 4	Block 5	Block 6	Block 7	Block 8
			J10 to J18	J20 to J28	J30 to J38	J40 to J48	J50 to J58	J60 to J68	J70 to J78	J80 to J88
J..0	Position [I05]	0								
J..1	Position mode	0								
J..2	Speed [I05/sec]	1000								
J..3	Accel [I05/sec ²]	1000								
J..4	Decel [I05/sec ²]	1000								
J..5	Repeat number	0								
J..6	Next block	0								
J..7	Next start	0								
J..8	Delay [sec]	0								

Parameter		DS	Entry							
L.. Posi. Command 2 (Expanded Process Block Parameters)										
			L10 to L12	L20 to L22	L30 to L32	L40 to L42	L50 to L52	L60 to L62	L70 to L72	L80 to L82
L..0	Brake	0								
L..1	Switch A	0								
L..2	Switch B	0								

Parameter		DS	Entry			
M.. Menu Skip (Menu jump destinations)						
			Jump to F1 M50 to M52	Jump to F2 M60 to M62	Jump to F3 M70 to M72	Jump to F4 M80 to M82
M50	F1-jump to	E50				
M51	F1-lower limit					
M52	F1-upper limit					

Parameter		DS	Entry			
N.. Posi. Switches						
			Switch S1 N10 to N14	Switch S2 N20 to N24	Switch S3 N30 to N34	Switch S4 N40 to N44
N..0	S..-position [I05]	0				
N..1	S..-method	0				
N..2	S..-memory1	0				
N..3	S..-memory 2	0				
N..4	S..-memory 3	0				

Parameter		DS	Entry
U.. Protective Functions			
U00	Level low voltage	3	
U01	Time low voltage	2	
U10	Level temp. limit mot. i2t	1	
U11	Time temp. limit mot. i2t	30	
U20	Level drive overload	1	
U21	Time drive overload	10	
U22	Text drive overload	drive overload	
U30	Level acceleration overload	1	
U31	Time acceleration overload	5	
U32	Text acceleration overload	acceleration overload	
U40	Level break overload	1	
U41	Time break overload	5	
U42	Text break overload	break overload	
U50	Level operating range	1	
U51	Time operating range	10	
U52	Text operating range	operating	
U60	Level following error	3	
U61	Time following error	500	
U70	Level Posi.refused	1	





= Standard menu level. Cf. para **A10**
Extended menu level: **A10=1**

DS = Default setting

* = Depends on type

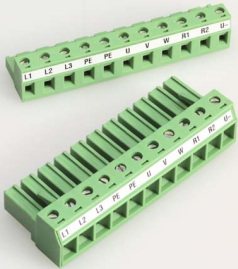
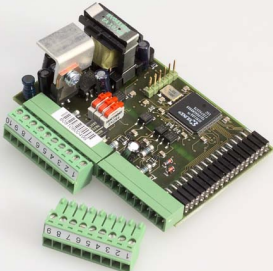
21. Accessories

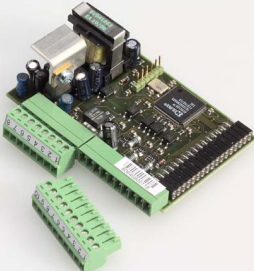
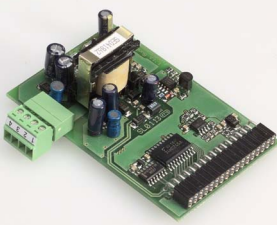



21.1 Accessories overview

	Id. No.	Designation	Remark
	41770	BG1 Connector for DC link (only FDS)	Chap. 4
	41771	BG2	
	43414	Option board EA4001 Encoder connection TTL or HTL (can be switched), 5 additional binary inputs, 3 binary output, external 24 V supply for encoder and inverter.	Chap. 14.1
	43415	Option board GB4001 Encoder connection TTL or HTL and buffered encoder output TTL or HTL (can be switched), one binary output, external 24 V supply for encoder and inverter.	Chap. 14.1
	43211	Option board SSI-4000 Connection of multi-turn, absolute-value encoders with synchronous-serial interface (SSI) for positioning tasks. In addition: 5 binary inputs and 4 binary outputs plus external 24 V power supply for fieldbus systems.	Chap. 14.3
	43090	Option board ext. 24 V power supply External supply unit for converter and field bus option (communication box). Parameterisation and diagnostics can be performed at the device even without 400 V mains voltage.	Chap. 14.2
	43199	Option board ASI-4000 The option pcb contains an AS-i 4E/4A + 2E-P module. It offers a simple and safe possibility for connection to the AS interface.	ASi documentation: Publ. no. 441509 (german)
	43096	Holding bracket for option boards (only BG3)	Chap. 14.1

21. Accessories

	Id. No.	Designation	Remark
	40021	CAN bus, Kommubox Interface module for CAN bus with CANopen profile CIA/DS-301.	CAN bus documentations: Publ. no. 441532 (german) Publ. no. 441562 (english)
	40022	Profibus-DP, Kommubox Interface module for Profibus-DP.	Profibus-DP documentations: Publ. no. 441525 (german) Publ. no. 441535 (english)
	27350	Parabox Using Parabox, parameters can be transferred between two inverters or between inverter and PC.	Chap. 8.7
	Publ.-no. 441893	CD LIBRARY This CD-ROM contains: <ul style="list-style-type: none"> • Sample applications, • Documentation, • FDS-Tool (PC program for programming, operation and observation of the converters.) • Feldbus datas 	Download from: http://www.stoerber.de FDS-Tool documentations: Publ. no. 441349 (german) Publ. no. 441409 (english)
	41488	Connection cable G3 PC <-> FDS connection cable with 9-pin sub D plug connector, plug connector /socket.	Chap. 9.9



21. Accessories

	Id. No.	Designation	Remark
	42224	<p>External operator, CONTROLBOX Operating unit for parameterisation and operation of the converters. Connecting lead (2 m) is included in the scope of supply.</p>	<p>Controlbox documentations: Publ. no. 441445 (german) Publ. no. 441479 (english) Publ. no. 441651 (french)</p>
	42225	<p>External operator, in a built-in DIN housing 96x96 mm see above Protection rating IP54</p>	
	42558	<p>PC adapter with power pack Power supply for Controlbox for direct data exchange with the PC.</p>	Chap. 7
	42583	<p>PC adapter with PS/2 connector Power supply via PS/2 interface for Controlbox for direct data exchange with the laptop.</p>	Chap. 7
	44969	<p>Inrush-current limiter ESB10 Inrush-current limiting for operation of several inverter at one contactor. Applicable for the mounting on a mounting rail (35 mm) according to DIN EN 60175 TH35.</p>	<p>ESB10 documentation Publ. no. 441705 (german)</p>

21. Accessories

21.2 Braking resistor

21.2.1 Allocation of braking resistor to FBS/FDS 4000

Type	Id. No.	FZM			FZMU 		FZZM	VHPR 		VHPR
		135x35 100 W 300 Ω	200x35 150 W 300 Ω	200x35 150 W 100 Ω	400x65 600 W 100 Ω	400x65 600 W 30 Ω	400x65 1200 W 30 Ω	VHPR150V 150 W 300 Ω	VHPR150V 150 W 100 Ω	VHPR600V 600 W 100 Ω
		40374	40375	25863	49010	49011	41642	45972	45973	44316
FBS 4008/B	42004	-	-	X	-	-	-	-	X	-
FBS 4013/B	42005	-	-	X	-	-	-	-	X	-
FDS 4014/B	42007	X	X	-	-	-	-	X	-	-
FDS 4024/B	42008	X	X	-	-	-	-	X	-	-
FBS 4028/B	42006	-	-	X	X	-	-	-	X	X
FDS 4040/B	42009	-	-	X	X	-	-	-	X	X
FDS 4070/B	42010	-	-	X	X	-	-	-	X	X
FDS 4085/B	42011	-	-	X	X	-	-	-	X	X
FDS 4110/B	42012	-	-	-	-	X	X	-	-	-
FDS 4150/B	42013	-	-	-	-	X	X	-	-	-
FDS 4220/B	42014	-	-	-	-	X	X	-	-	-
FDS 4270/B	42075	-	-	-	-	X	X	-	-	-
FDS 4300/B	43095	-	-	-	-	X	X	-	-	-

21.2.2 Braking resistor FZM(U) / FZZM (dimensions)

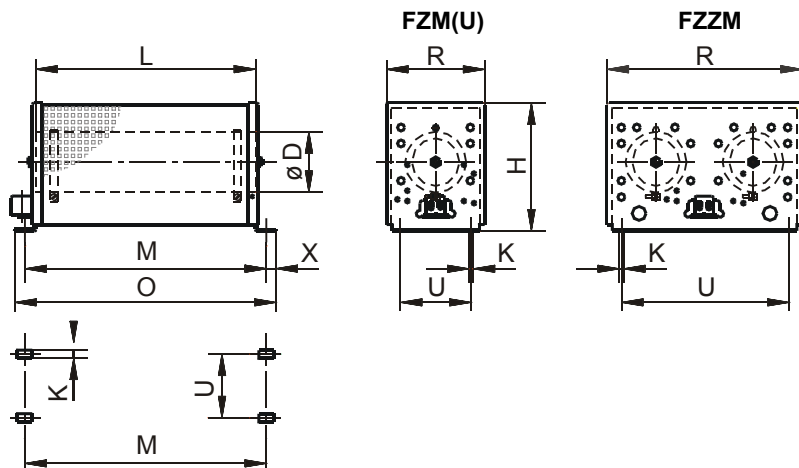

Type	FZM 135x35	FZM 200x35	FZMU 400x65	FZZM 400x65
L x D	135 x 35	200 x 35	400 x 65	400 x 65
H	77	77	120	120
K	4.5 x 9	4.5 x 9	6.5 x 12	6.5 x 12
M	157	222	430	426
O	172	237	485	446
R	66	66	92	185
U	44	44	64	150
X	7	7	10	10
Weight [kg]	0.6	0.7	2.2	4.2

[dimensions in mm]

21. Accessories

21.2.3 Braking resistor VHPR (dimensions)

Typ	VHPR150V 150 W 300 Ω	VHPR150V 150 W 100 Ω	VHPR600V 600 W 100 Ω
L	212	212	420
C	193	193	400
B	40	40	60
A	21	21	31
D	4.3	4.3	5.3
E	8	8	11.5
F	13	13	19.5
Weight [g]	Approx. 310	Approx. 310	Approx. 1300

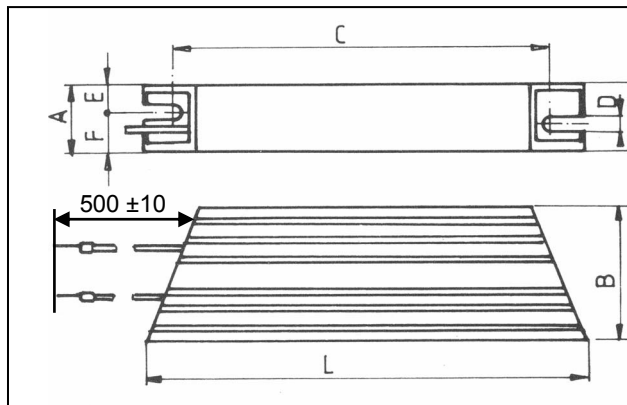

[dimensions in mm]

21.3 Output derating / output filter

21.3.1 Allocation of output derating / output filter to FBS/FDS 4000

Type	Id.-No.	Output derating			Output filter	
		RU 775 / 5 A _{eff}	RU 774 / 13 A _{eff}	RU 778 / 25 A _{eff}	MF1 / 3.5 A _{eff}	MF2 / 12 A _{eff}
		28206	28207	28208	43213	43214
FBS 4008/B	42004	X	-	-	X	-
FBS 4013/B	42005	X	-	-	X	-
FDS 4014/B	42007	X	-	-	X	-
FDS 4024/B	42008	X	-	-	X	-
FBS 4028/B	42006	-	X	-	-	X
FDS 4040/B	42009	X	-	-	-	X
FDS 4070/B	42010	-	X	-	-	X
FDS 4085/B	42011	-	X	-	-	X
FDS 4110/B	42012	-	-	X	-	-
FDS 4150/B	42013	-	-	X	-	-
FDS 4220/B	42014	-	-	Omitted or 2 x RU 778 parallel	-	-
FDS 4270/B	42075	-	-		-	-
FDS 4300/B	43095	-	-		-	-

21.3.2 Output derating RU (dimensions)

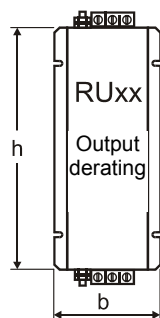

Type	RU 775 / 5 A _{eff}	RU 774 / 13 A _{eff}	RU 778 / 25 A _{eff}
W x H x DT (in mm)	70 x 160 x 55	105 x 240 x 80	90 x 350 x 90
Max. line cross section	6 mm ² (rigid) or 4 mm ² (flexible)		

21.3.3 Output filter MF (dimensions)

Output filter	MF1 / 3.5 A _{eff}	MF2 / 12 A _{eff}
A	93	120
B	71	86
C	96	111
D	43 to 51	47 to 56

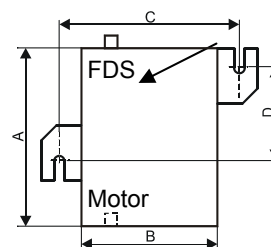

Screw exists already.

Additional information under:
<http://www.stoeber.de>

STÖBER . . . The Drive for Your Automation



STÖBER ANTRIEBSTECHNIK
GmbH + Co. KG

GERMANY
Kieselbronner Strasse 12 · 75177 Pforzheim
Postfach 910103 · 75091 Pforzheim
Fon +49 (0) 7231 582-0, Fax +49 (0) 7231 582-1000
Internet: <http://www.stoeber.de> / e-Mail: mail@stoeber.de

Presented by: